



Service and Repair Manual

Z[®]-135/70

Serial Number Range

from Z13505-101 to
Z13513-2000

This manual includes:
Repair procedures
Fault Codes
Electrical and
Hydraulic Schematics

For detailed maintenance
procedures, refer to the
appropriate Maintenance
Manual for your machine.

Part No. 1268557GT
Rev A3
March 2018

Introduction

Important

Read, understand and obey the safety rules and operating instructions in the appropriate Operator's Manual on your machine before attempting any procedure.

This manual provides troubleshooting and repair procedures for qualified service professionals.

Basic mechanical, hydraulic and electrical skills are required to perform most procedures. However, several procedures require specialized skills, tools, lifting equipment and a suitable workshop. In these instances, we strongly recommend that maintenance and repair be performed at an authorized Genie dealer service center.

Compliance

Machine Classification

Group B/Type 3 as defined by ISO 16368

Machine Design Life

Unrestricted with proper operation, inspection and scheduled maintenance.

Technical Publications

Genie has endeavored to deliver the highest degree of accuracy possible. However, continuous improvement of our products is a Genie policy. Therefore, product specifications are subject to change without notice.

Readers are encouraged to notify Genie of errors and send in suggestions for improvement. All communications will be carefully considered for future printings of this and all other manuals.

Contact Us:

Internet: www.genielift.com
E-mail: awp.techpub@terex.com

Find a Manual for this Model

Go to <http://www.genielift.com>

Use the links to locate Service Manuals, Maintenance Manuals, Service and Repair Manuals, Parts Manuals and Operator's Manuals.

Copyright © 2015 by Terex Corporation

1268557 Rev A, September 2015

First Edition, First Printing

Genie is a registered trademark of Terex South Dakota, Inc. in the U.S.A. and many other countries.

"Z" is a trademark of Terex South Dakota, Inc.

Introduction

Revision History

Revision	Date	Section	Procedure / Page / Description
A	9/2015		Initial Release
A1	11/2015	Schematics	Wire Color Legend
A2	6/2016	Specifications	Performance Specifications
		Repair	Procedures 4-9, 6-1
A3	3/2018	Repair	Display Module
Reference Examples:			Electronic Version Click on any content or procedure in the Table of Contents to view the update.
Section – Repair Procedure, 4-2			
Section – Fault Codes, All charts			
Section – Schematics, Legends and schematics			

Introduction

Serial Number Legend



A TEREX BRAND

Model: Z-135/70
Serial number: Z13505-12345
Model year: 2005 **Manufacture date:** 04/12/05
Electrical schematic number: ES0366
Machine unladen weight:

Rated work load (including occupants): 600 lb / 273 kg
Maximum number of platform occupants: 2
Maximum allowable side force : 150 lb / 670 N
Maximum allowable inclination of the chassis:
 0 deg
Maximum wind speed : 28 mph/ 12.5 m/s
Maximum platform height : 135 ft/ 41.15 m
Maximum platform reach : 69 ft 9 in/ 21.26 m
Gradeability: 45%
Country of manufacture: USA
This machine complies with:
 ANSI A92.5
 CAN B.354.4

Terex South Dakota, Inc.
 500 Oakwood Road
 PO Box 1150
 Watertown, SD 57201
 USA



PN - 77055

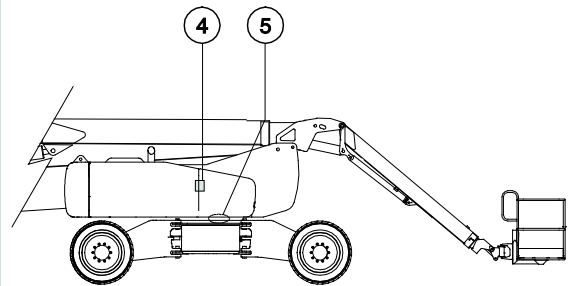
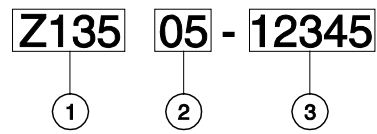

- 1 Model
- 2 Model year
- 3 Sequence number
- 4 Serial label (located under cover)
- 5 Serial number (stamped on chassis)

Safety Rules



Danger

Failure to obey the instructions and safety rules in this manual and the appropriate Operator's Manual on your machine will result in death or serious injury.

Many of the hazards identified in the operator's manual are also safety hazards when maintenance and repair procedures are performed.

Do Not Perform Maintenance Unless:

- You are trained and qualified to perform maintenance on this machine.
- You read, understand and obey:
 - manufacturer's instructions and safety rules
 - employer's safety rules and worksite regulations
 - applicable governmental regulations
- You have the appropriate tools, lifting equipment and a suitable workshop.

Safety Rules

Personal Safety

Any person working on or around a machine must be aware of all known safety hazards. Personal safety and the continued safe operation of the machine should be your top priority.



Read each procedure thoroughly. This manual and the decals on the machine, use signal words to identify the following:



Safety alert symbol—used to alert personnel to potential personal injury hazards. Obey all safety messages that follow this symbol to avoid possible injury or death.



Indicates a imminently hazardous situation which, if not avoided, will result in death or serious injury.



Indicates a potentially hazardous situation which, if not avoided, could result in death or serious injury.



Indicates a potentially hazardous situation which, if not avoided, may cause minor or moderate injury.



Indicates a potentially hazardous situation which, if not avoided, may result in property damage.



Be sure to wear protective eye wear and other protective clothing if the situation warrants it.



Be aware of potential crushing hazards such as moving parts, free swinging or unsecured components when lifting or placing loads. Always wear approved steel-toed shoes.

Workplace Safety

Any person working on or around a machine must be aware of all known safety hazards. Personal safety and the continued safe operation of the machine should be your top priority.



Be sure to keep sparks, flames and lighted tobacco away from flammable and combustible materials like battery gases and engine fuels. Always have an approved fire extinguisher within easy reach.



Be sure that all tools and working areas are properly maintained and ready for use. Keep work surfaces clean and free of debris that could get into machine components and cause damage.



Be sure any forklift, overhead crane or other lifting or supporting device is fully capable of supporting and stabilizing the weight to be lifted. Use only chains or straps that are in good condition and of ample capacity.



Be sure that fasteners intended for one time use (i.e., cotter pins and self-locking nuts) are not reused. These components may fail if they are used a second time.



Be sure to properly dispose of old oil or other fluids. Use an approved container. Please be environmentally safe.



Be sure that your workshop or work area is properly ventilated and well lit.

Table of Contents

Introduction	Introduction	ii
	Important Information	ii
	Find a Manual for this Model.....	ii
	Serial Number Legend	iv

Section 1	Safety Rules	v
	General Safety Rules	v

Section 2	Specifications	1
	Machine Specifications.....	1
	Performance Specifications.....	1
	Hydraulic Specification	2
	Hydraulic Component Specifications.....	5
	Deutz BF4L 2011 Engine Specifications	7
	Deutz TD2011L04i Engine Specifications	9
	Cummins B4.5L Engine Specifications	11
	Cummins B3.3T Engine Specifications	13
	Perkins 1104C-44 Engine Specifications	15
	Perkins 804D-33T Engine Specifications	17
	Machine Torque Specifications	19
	Hydraulic Hose and Fitting Torque Specifications	20
	Torque Procedure	21
	SAE and Metric Fasteners Torque Charts	23

Table of Contents

Section 3	Repair Procedures	24
	Introduction	24
	Platform Controls.....	26
	Platform Controls	26
	1-1 Platform Circuit Board.....	27
	How to Remove the LED Circuit Board	28
	1-2 Membrane Decal	29
	1-3 Joysticks - How to Calibrate a Joystick	30
	How to Reset a Proportional Valve Coil Default	34
	How to Set the Function Thresholds and Default Functions Speeds	34
	How to Adjust the Function Speeds	36
	How to Adjust the Function Ramp Rate Setting	37
	Platform Components	39
	2-1 Platform Leveling Cylinder.....	39
	2-2 Platform Rotator.....	40
	How to Bleed the Platform Rotator	41
	2-3 Platform Level Sensor - How to Calibrate the Platform Level Sensor.....	42
	2-4 Platform Overload System (if equipped).....	43
	Jib Boom Components.....	46
	3-1 Jib Boom Cable Track	47
	How to Repair the Cable Track.....	49
	3-2 Jib Boom.....	50
	3-3 Jib Boom Lift Cylinder.....	52
	3-4 Jib Boom Level Cylinder.....	53
	3-5 Jib Boom Extension Cylinder.....	54
	3-6 Jib Boom Bellcrank Angle Sensor	56
	How to Calibrate the Jib Boom Bellcrank Angle Sensor	58

Table of Contents

Boom Components	64
4-1 Primary Boom Cable Track	65
How to Repair the Primary Boom Cable Track	67
4-2 Secondary Boom Cable Track	68
How to Repair the Secondary Boom Cable Track	70
4-3 Primary Boom.....	71
4-4 Primary Boom Lift Cylinder	73
4-5 Secondary Boom Lift Cylinder.....	74
4-6 Primary Boom Extension Cylinder	78
4-7 Secondary Boom Extension Cylinders.....	79
4-8 Primary Boom Angle Sensor.....	81
How to Calibrate the Primary Boom Angle Sensor	82
4-9 Secondary Boom Angle Sensor	88
How to Calibrate the Secondary Boom Angle Sensor	89
Engines.....	95
5-1 RPM Adjustment	95
5-2 Flex Plate	95
How to install a Type "A" Flex Plate	96
How to install a Type "B" Flex Plate	98
Ground Controls.....	99
6-1 Bypass/Recovery Key Switch	99
How to Use the Recovery Mode	101
6-2 Circuit Boards.....	102
6-3 Membrane Decal.....	104
6-4 Full Machine Calibration.....	105
Display Module	106

Table of Contents

Hydraulic Pumps	115
7-1 Function Pump.....	115
How to Prime the Function Pump.....	116
How to Adjust the Function Pump Standby Pressure.....	116
How to Adjust the Function Pump Pressure Compensator.....	117
7-2 Drive Pump.....	118
How to Prime the Drive Pump.....	119
Manifolds	120
8-1 Function Manifold - (before serial number 440).....	120
8-2 Function Manifold - (after serial number 439).....	124
8-3 Valve Adjustments - Function Manifold.....	128
How to Adjust the System Relief Valve.....	128
How to Adjust the Primary Boom Extend Relief Valve.....	129
8-4 Platform Manifold.....	131
8-5 Jib Boom Manifold.....	132
8-6 Flow Control Mainfold.....	134
8-7 Function Enable Valve.....	135
8-8 Turntable Rotation Manifold.....	136
8-9 Steer and Axle Manifold.....	138
8-10 Valve Adjustments - Steer and Axle Manifold.....	142
8-11 Traction Manifold.....	144
8-12 Valve Adjustments - Traction Manifold.....	148
8-13 Drive Oil Diverter Manifold (welder option).....	149
8-14 Valve Coils.....	150
Turntable Rotation Components	152
9-1 Turntable Rotation Assembly.....	152
How to Adjust the Turntable Rotation Gear Backlash.....	153
9-2 Turntable Level Sensor - How to Calibrate the Turntable Level Sensor.....	154

Table of Contents

Axle Components	158	
10-1 Steer Sensors	158	
How to Calibrate a Replacement Steer Sensor	160	
How to Calibrate All Steer Sensors	161	
10-2 Steer Cylinders	163	
10-3 Axle Extension Cylinders	164	
10-4 Axle Angle Sensors	165	
How to Calibrate the Axle Angle Sensors	167	
<hr/>		
Section 4	Fault Codes	171
	Introduction	171
	Control System Fault Codes	172
	Fault Matrix	189

Table of Contents

Section 5	Schematics	191
	Introduction	191
	Wire Circuit Legend	192
	Wire Color Legend	196
	Limit Switches and Angle Sensors.....	201
	Circuit Connector Legend	205
	Drive Chassis and Platform Controller Pin Legend	208
	Safety Controller Pin Legend	209
	Turntable Controller Pin Legend	210
	Engine Relay and Fuse Panel Legend - Deutz BF4L 2011, TD2011L04i, Perkins 1104C-44 and 804D-33T	211
	Engine Relay and Fuse Panel Legend - Cummins B4.5L and B3.3T	212
	Electrical Symbols Legend.....	213
	Hydraulic Symbols Legend	214
	Perkins 1104C-44 and 804D-33T Engine Electrical Schematic	216
	Cummins B4.5L and B3-3.3T Engine Electrical Schematic.....	217
	Generator Wiring Schematic.....	220
	Hydraulic Generator (Welder Option)	221
	Hydraulic Schematic (before serial number 180, except for serial number 102).....	224
	Hydraulic Schematic (serial number 102 and from serial number 180 to 534)..	225
	Hydraulic Schematic (from serial number 535).....	227
	Electrical Schematic.....	229

This page intentionally left blank.

Specifications

Machine Specifications

Tires and wheels

Tire size	445/65D22.5, FF
Tire ply rating	18
Tire weight, new foam-filled (minimum)	815 lbs 370 kg
Overall tire diameter	46.5 in 118.1 cm
Wheel diameter	22.5 in 57.2 cm
Wheel width	13 in 33 cm
Wheel lugs	10 @ 3/4 -16
Lug nut torque, dry	420 ft-lbs 569.4 Nm
Lug nut torque, lubricated	320 ft-lbs 433.9 Nm

Fluid capacities

Fuel tank	40 gallons 151.4 liters
Hydraulic tank	65 gallons 246 liters
Hydraulic system (including tank)	123 gallons 466 liters
Drive hubs	47 fl oz 1390 cc
Turntable rotation drive hub	40 fl oz 1183 cc
Drive hub oil type: SAE 90 multipurpose hypoid gear oil API service classification GL5	

Performance Specifications

Drive speed, maximum

Stowed position, high speed	2.8 mph 4.5 km/h 40 ft / 9.7 sec 12.2 m / 9.7 sec
Raised or extended	0.7 mph 1.1 km/h 40 ft / 40 sec 12.2 m / 40 sec
Primary and Secondary booms raised, and Primary and Jib extended	0.4 mph 0.6 km/h 40 ft / 68.5 sec 12.2 m / 68.5 sec

Braking distance, maximum

High range on paved surface	3 to 6 ft 1 to 2 m
-----------------------------	-----------------------

Gradeability	See Operator's Manual
--------------	-----------------------

Boom function speeds, maximum from platform controls

Jib boom up/down	38 to 43 seconds
Jib boom extend/retract	38 to 42 seconds
Primary boom up/down -60° to +70°	110 to 125 seconds
Primary boom extend/retract	35 to 48 seconds
Secondary boom up/down	80 to 95 seconds
Secondary boom extend/retract	88 to 98 seconds
Turntable rotate, 360° fully stowed	88 to 92 seconds
Turntable rotate, 360° jib or primary booms extended	160 to 180 seconds
Turntable rotate, 360° jib and primary booms extended	280 to 350 seconds

For operational specifications, refer to the Operator's Manual.

Continuous improvement of our products is a Genie policy. Product specifications are subject to change without notice or obligation.

Specifications

Hydraulic Oil Specifications

Hydraulic Fluid Specifications

Genie specifications require hydraulic oils which are designed to give maximum protection to hydraulic systems, have the ability to perform over a wide temperature range, and the viscosity index should exceed 140. They should provide excellent antiwear, oxidation prevention, corrosion inhibition, seal conditioning, and foam and aeration suppression properties.

Cleanliness level, minimum	ISO 15/13
-------------------------------	-----------

Water content, maximum	250 ppm
---------------------------	---------

Recommended Hydraulic Fluid

Hydraulic oil type	Chevron Rando HD Premium
--------------------	--------------------------

Viscosity grade	32
-----------------	----

Viscosity index	200
-----------------	-----

Optional Hydraulic Fluids

Mineral based	Shell Tellus S2 V 32
	Shell Tellus S2 V 46
	Shell Tellus S4 VX 32 Shell
	Shell Donax TG (Dexron III)
	Chevron 5606A

Biodegradable	Petro Canada Environ MV 46
---------------	----------------------------

Fire resistant	UCON Hydrolube HP-5046
----------------	------------------------

Note: Genie specifications require additional equipment and special installation instructions for the approved optional fluids. Consult Genie Product Support before use.

NOTICE

Optional fluids may not have the same hydraulic lifespan and may result in component damage.

Note: Extended machine operation can cause the hydraulic fluid temperature to increase beyond its maximum allowable range. If the hydraulic fluid temperature consistently exceeds 200°F / 90°C an optional oil cooler may be required.

NOTICE

Do not top off with incompatible hydraulic fluids. Hydraulic fluids may be incompatible due to the differences in base additive chemistry. When incompatible fluids are mixed, insoluble materials may form and deposit in the hydraulic system, plugging hydraulic lines, filters, control valves and may result in component damage.

Note: Do not operate the machine when the ambient air temperature is consistently above 120°F / 49°C.

Hydraulic Fluid Temperature Range

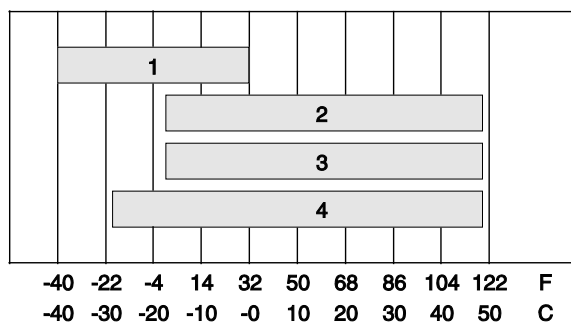

Ambient air temperature

- 1 Chevron hydraulic oil 5606A
- 2 Petro-Canada Environ MV 46
- 3 UCON Hydrolube HP-5046D
- 4 Chevron Rando HD premium oil MV

Specifications

Chevron Rando HD Premium Oil MV Fluid Properties

ISO Grade	32
Viscosity index	200
Kinematic Viscosity cSt @ 200°F / 100°C	7.5
cSt @ 104°F / 40°C	33.5
Brookfield Viscosity cP @ -4°F / -20°C	1040
cP @ -22°F / -30°C	3310
Flash point	375°F / 190°C
Pour point	-58°F / -50°C
Maximum continuous operating temperature	171°F / 77°C

Note: A hydraulic oil heating system is recommended when the ambient temperature is consistently below 0°F / -18°C.

Note: Do not operate the machine when the ambient temperature is below -20°F / -29°C with Rando HD Premium MV.

Chevron 5606A Hydraulic Oil Fluid Properties

ISO Grade	15
Viscosity index	300
Kinematic Viscosity cSt @ 200°F / 100°C	5.5
cSt @ 104°F / 40°C	15.0
cSt @ -40°F / -40°C	510
Flash point	180°F / 82°C
Pour point	-81°F / -63°C
Maximum continuous operating temperature	124°F / 51°C

Note: Use of Chevron 5606A hydraulic fluid, or equivalent, is required when ambient temperatures are consistently below 0°F / -17°C unless an oil heating system is used.

NOTICE

Continued use of Chevron 5606A hydraulic fluid, or equivalent, when ambient temperatures are consistently above 32°F / 0°C may result in component damage

Specifications

Petro-Canada Environ MV 46 Fluid Properties

ISO Grade	46
Viscosity index	154
Kinematic Viscosity cSt @ 200°F / 100°C	8.0
cSt @ 104°F / 40°C	44.4
Flash point	482°F / 250°C
Pour point	-49°F / -45°C
Maximum continuous operating temperature	180°F / 82°C

Shell Tellus S4 VX Fluid Properties

ISO Grade	32
Viscosity index	300
Kinematic Viscosity cSt @ 200°F / 100°C	9
cSt @ 104°F / 40°C	33.8
Brookfield Viscosity cSt @ -4°F / -20°C	481
cSt @ -13°F / -25°C	702.4
cSt @ -40°F / -40°C	2624
Flash point	>100
Pour point	-76°F / -60°C
Maximum continuous operating temperature	103°F / 75°C

UCON Hydrolube HP-5046 Fluid Properties

ISO Grade	46
Viscosity index	192
Kinematic Viscosity cSt @ 149°F / 65°C	22
cSt @ 104°F / 40°C	46
cSt @ 0°F / -18°C	1300
Flash point	None
Pour point	-81°F / -63°C
Maximum continuous operating temperature	189°F / 87°C

Specifications

Hydraulic Component Specifications

Drive Pump

Type: bi-directional variable displacement piston pump	
Displacement per revolution	2.8 cu in 46 cc
Flow rate @ 2350 rpm	28.5 gpm 108 L/min
Drive pressure, maximum	3625 psi 250 bar

Charge Pump

Type	gerotor
Displacement per revolution	0.85 cu in 13.9 cc
Flow rate @ 2350 rpm	9 gpm 34 L/min
Charge pressure @ 2350 rpm Neutral position	315 ps i21.7 bar

Function pump

Type: variable displacement piston pump	
Displacement per revolution	0 to 2.75 cu in 0 to 45 cc
Flow rate @ 2350 rpm	0 to 28 gpm 0 to 106 L/min
Pressure, maximum	2900 psi 200 bar
Pressure compensator	2900 psi 200 bar
Standby pressure	250 psi 17 bar

Auxiliary Pump

Type: fixed displacement gear pump	
Displacement per revolution	0.15 cu in 2.47 cc

Function manifold

System relief valve pressure, maximum (measured at test port)	3100 psi 213.7 bar
Primary boom extend relief pressure (measured at ptest port)	2600 psi 179 bar

Jib and platform manifolds

Platform rotate and platform level flow regulator	0.2 gpm 0.76 L/min
Jib manifold flow regulator	2 gpm 7.6 L/min

Steer/Axle Manifold

Axle extend relief pressure	2400 psi 165 bar
-----------------------------	---------------------

Traction Manifold

Hot oil relief pressure	250 psi 17.2 bar
-------------------------	---------------------

Hydraulic Filters

High pressure filter:	Beta 3 ≥ 200
High pressure filter bypass pressure	102 psi 7 bar
Medium pressure filter	Beta 3 ≥ 200
Medium pressure filter bypass pressure	51 psi 3.5 bar
Hydraulic tank return filter	10 micron with 25 psi / 1.7 bar bypass
Drive motor case drain return filter	Beta 10 ≥ 2

Continuous improvement of our products is a Genie policy. Product specifications are subject to change without notice or obligation.

Specifications

Brakes

Brake relief pressure	190 psi 13 bar
-----------------------	-------------------

Drive Motors (before serial number 180) (see note below)

Displacement per revolution, high speed	0.8 cu in 13.3 cc
Displacement per revolution, low speed (square end)	2.7 cu in 45 cc
Displacement per revolution, low speed (circle end)	1.5 cu in 25 cc

Drive Motors (after serial number 179)

Displacement per revolution, high speed	0.8 cu in 13.3 cc
Displacement per revolution, low speed (square end)	2.7 cu in 45 cc
Displacement per revolution, low speed (circle end)	1.5 cu in 25 cc

Note: Serial number 102 is equipped with drive motors equal to those used on machines after serial number 179.

Manifold Component Specifications

Plug torque

SAE No. 2	36 in-lbs / 4 Nm
SAE No. 4	10 ft-lbs / 13 Nm
SAE No. 6	14 ft-lbs / 19 Nm
SAE No. 8	38 ft-lbs / 51 Nm
SAE No. 10	41 ft-lbs / 55 Nm
SAE No. 12	56 ft-lbs / 76 Nm

Valve coil resistance specifications

Proportional solenoid valve (schematic items N, P, R, T, V)	3.5 to 5.5Ω
Solenoid valve, 3 position 4 way (schematic item B)	4 to 6Ω
Solenoid valve, 3 position 4 way (schematic items BN, BO, BP, BQ)	7 to 9Ω
Solenoid valve, 3 position 4 way (schematic item AH)	8 to 10Ω
Proportional solenoid valve, 3 position 4 way (schematic items Y, AI)	8 to 10Ω
Solenoid Valve, 2 position 3 way (schematic items F and AD)	5.5 to 7.5Ω
Solenoid Valve, 2 position 3 way (schematic items AE, AF)	8 to 10Ω
Solenoid valve, 2 position 2 way (schematic items H, J)	3.5 to 5.5Ω
Solenoid Valve, 2 position 3 way (schematic items C, D, G, I, K, AX, AY, BU, BT)	7.5 to 9.5Ω
Solenoid valve, 2 position 2 way (schematic item A)	3.5 to 5.5Ω

Continuous improvement of our products is a Genie policy. Product specifications are subject to change without notice or obligation.

Specifications

Deutz BF4L 2011 Engine

Displacement	189.6 cu. in 3.1 liters
Number of cylinders	4
Bore and Stroke	3.7 x 4.409 inches 94 x 112 mm
Horsepower net intermittent	
Continuous @ 2500 rpm	69 hp / 51 kW
Net intermittent @ 2500 rpm	73 hp / 54 kW
Firing order	1 - 3 - 4 - 2
Low idle	1500 rpm 383 Hz
High idle	2350 rpm 599 Hz
Compression ratio	17.5:1
Compression pressure (psi or bar) of the lowest cylinder must be at least 75% of the highest cylinder	
Governor	centrifugal mechanical
Valve Clearance, cold	
Intake	0.012 in 0.3 mm
Exhaust	0.020 in 0.5 mm

Lubrication system

Oil pressure, hot (@ 2000 rpm)	40 to 60 psi 2.8 to 4.1 bar
Oil capacity (including filter)	11 quarts 10.4 liters

Oil viscosity requirements

-22°F to 86°F / -30°C to 30°C	5W-30 (synthetic)
-4°F to 90°F / -20°C to 32°C	10W-40
Above 23°F / -5°C	20W-50

Unit ships with 15W-40. Extreme operating temperatures may require the use of alternative engine oils. For oil requirements, refer to the Engine Operator Manual for your engine.

Oil temperature switch

Installation torque	8 - 18 ft-lbs 11 - 24 Nm
Temperature switch point	275°F 135°C

Oil Pressure switch

Installation torque	8 - 18 ft-lbs 11 - 24 Nm
Pressure switch point	7 psi 0.48 bar

Continuous improvement of our products is a Genie policy. Product specifications are subject to change without notice or obligation.

Specifications

Deutz BF4L 2011 cont.

Fuel injection system	Motorpal
Injection pump pressure, maximum	15,000 psi 1034 bar
Injector opening pressure	3046 psi 210 bar

Fuel requirement

For fuel requirements, refer to the engine Operator Manual for your engine.

Starter motor

Current draw, normal load	140 - 200A
Cranking speed	200 - 250 rpm

Battery – Auxiliary power units

Type	6V DC
Quantity	2
Battery capacity, maximum	285 AH
Reserve capacity @ 25A rate	745 minutes

Battery – Engine starting and control system

Type	12V DC, Group 31
Quantity	1
Battery capacity, maximum	1000A
Reserve capacity @ 25A rate	200 Minutes

Alternator output	80A @ 14V DC
--------------------------	--------------

Fan belt deflection	3/8 to 1/2 inch 9.5 to 12.5 mm
----------------------------	-----------------------------------

Continuous improvement of our products is a Genie policy. Product specifications are subject to change without notice or obligation.

Specifications

Deutz TD2011L04i Engine

Displacement	220.9 cu. in 3.62 liters
Number of cylinders	4
Bore and Stroke	3.78 x 4.92 inches 96 x 125 mm
Horsepower net intermittent @ 2400 rpm	74 hp / 55 kW
Induction system	turbocharged
Firing order	1 - 3 - 4 - 2
Low idle	1500 rpm 383 Hz
High idle	2350 rpm 599 Hz
Compression ratio	17.5:1
Compression pressure (psi or bar) of the lowest cylinder must be at least 75% of the highest cylinder	
Governor	centrifugal mechanical
Valve Clearance, cold	
Intake	0.012 in 0.3 mm
Exhaust	0.020 in 0.5 mm

Lubrication system

Oil pressure, hot (@ 2000 rpm)	40 to 60 psi 2.8 to 4.1 bar
Oil capacity (including filter)	12.8 quarts 12.1 liters

Oil viscosity requirements

-22°F to 86°F / -30°C to 30°C	5W-30 (synthetic)
-4°F to 104°F / -20°C to 40°C	10W-40
Above 5°F / -15°C	15W-40

Unit ships with 15W-40. Extreme operating temperatures may require the use of alternative engine oils. For oil requirements, refer to the Engine Operator Manual for your engine.

Oil temperature switch

Installation torque	8 - 18 ft-lbs 11 - 24 Nm
Temperature switch point	275°F 135°C

Oil Pressure switch

Installation torque	8 - 18 ft-lbs 11 - 24 Nm
Pressure switch point	22 psi 1.5 bar

Continuous improvement of our products is a Genie policy. Product specifications are subject to change without notice or obligation.

Specifications

Deutz TD2011L04i cont.

Fuel injection system	Motorpal
Injection pump pressure, maximum	15,000 psi 1034 bar
Injector opening pressure	3046 psi 210 bar

Fuel requirement

For fuel requirements, refer to the engine Operator Manual for your engine.

Starter motor

Current draw, normal load	140 - 200A
Cranking speed	250 - 350 rpm

Battery – Auxiliary power units

Type	6V DC
Quantity	2
Battery capacity, maximum	285 AH
Reserve capacity @ 25A rate	745 minutes

Battery – Engine starting and control system

Type	12V DC, Group 31
Quantity	1
Battery capacity, maximum	1000A
Reserve capacity @ 25A rate	200 Minutes

Alternator output	80A @ 14V DC
--------------------------	--------------

Fan belt deflection	3/8 to 1/2 inch 9.5 to 12.5 mm
----------------------------	-----------------------------------

Continuous improvement of our products is a Genie policy. Product specifications are subject to change without notice or obligation.

Specifications

Cummins B4.5L Engine

Displacement	275 cu. in 4.5 liters
Number of cylinders	4
Bore and Stroke	4.02 x 5.42 inches 102 x 138 mm
Horsepower net intermittent @ 2200 rpm	80 hp / 60 kW
Firing order	1 - 3 - 4 - 2
Low idle	1300 rpm 368 Hz
High idle	2350 rpm 599 Hz
Compression ratio	18:1
Compression pressure (psi or bar) of the lowest cylinder must be at least 75% of the highest cylinder	
Governor	centrifugal mechanical
Valve Clearance, cold	
Intake	0.010 in 0.254 mm
Exhaust	0.020 in 0.508 mm

Lubrication system

Oil pressure, hot (@ 2000 rpm)	50 psi 3.45 bar
Oil capacity (including filter)	9.5 quarts 9 liters

Oil viscosity requirements

Below 68°F / 20°C	5W-30
-10°F to 68°F / -23°C to 20°C	10W-40
Above 15°F / -9°C	15W-40

Unit ships with 15W-40. Extreme operating temperatures may require the use of alternative engine oils. For oil requirements, refer to the Engine Operator Manual for your engine.

Continuous improvement of our products is a Genie policy. Product specifications are subject to change without notice or obligation.

Specifications

Cummins B4.5L cont.

Fuel injection system

	Delphi
Injection pump pressure, maximum	3480 to 3680 psi 240 to 254 bar
Injector opening pressure	3480 psi 240 bar

Fuel requirement

For fuel requirements, refer to the engine Operator Manual for your engine.

Engine coolant

Capacity	17 quarts 16 liters
----------	------------------------

Coolant temperature switch

Installation torque	8 - 18 ft-lbs 11 - 24 Nm
Temperature switch point	230°F 110°C

Starter motor

Current draw, no load	125A
Brush length, minimum	0.72 in 18.3 mm

Battery – Auxiliary power units

Type	6V DC
Quantity	2
Battery capacity, maximum	285 AH
Reserve capacity @ 25A rate	745 minutes

Battery – Engine starting and control system

Type	12V DC, Group 31
Quantity	1
Battery capacity, maximum	1000A
Reserve capacity @ 25A rate	200 Minutes

Alternator output

95A @ 12V DC

Fan belt deflection	3/8 to 1/2 inch 9.5 to 12.5 mm
---------------------	-----------------------------------

Continuous improvement of our products is a Genie policy. Product specifications are subject to change without notice or obligation.

Specifications

Cummins B3.3T Engine

Displacement	199 cu. in 3.26 liters
Number of cylinders	4
Bore and Stroke	3.74 x 4.53 inches 95 x 115 mm
Horsepower net intermittent @ 2200 rpm	80 hp / 60 kW
Firing order	1 - 2 - 4 - 3
Low idle	1300 rpm 368 Hz
High idle	2350 rpm 599 Hz
Compression ratio	17:1
Compression pressure (psi or bar) of the lowest cylinder must be at least 75% of the highest cylinder	
Valve Clearance, cold	
Intake	0.014 in 0.35 mm
Exhaust	0.020 in 0.508 mm

Lubrication system

Oil pressure, hot (@ 2000 rpm)	31 psi 72 bar
Oil capacity (including filter)	9 quarts 8.5 liters

Oil viscosity requirements

Below 68°F / 20°C	5W-30
-10°F to 68°F / -23°C to 20°C	10W-40
Above 14°F / -10°C	15W-40

Unit ships with 15W-40. Extreme operating temperatures may require the use of alternative engine oils. For oil requirements, refer to the Engine Operator Manual for your engine.

Continuous improvement of our products is a Genie policy. Product specifications are subject to change without notice or obligation.

Specifications

Cummins B3.3T cont.

Fuel injection system	Zexel
------------------------------	-------

Injection pump pressure, maximum	12,000 psi 827 bar
----------------------------------	-----------------------

Fuel requirement

For fuel requirements, refer to the engine Operator Manual for your engine.

Engine coolant

Capacity	9.1 quarts 8.6 liters
----------	--------------------------

Starter motor

Current draw, maximum load	550A
----------------------------	------

Cranking speed	130 rpm
----------------	---------

Battery – Auxiliary power units

Type	6V DC
------	-------

Quantity	2
----------	---

Battery capacity, maximum	285 AH
---------------------------	--------

Reserve capacity @ 25A rate	745 minutes
-----------------------------	-------------

Battery – Engine starting and control system

Type	12V DC, Group 31
------	------------------

Quantity	1
----------	---

Battery capacity, maximum	1000A
---------------------------	-------

Reserve capacity @ 25A rate	200 Minutes
-----------------------------	-------------

Alternator output	120A @ 12V DC
--------------------------	---------------

Fan belt deflection	3/8 to 1/2 inch 9.5 to 12.5 mm
----------------------------	-----------------------------------

Continuous improvement of our products is a Genie policy. Product specifications are subject to change without notice or obligation.

Specifications

Perkins 1104C-44

Displacement	268.5 cu. in 4.4 liters
Number of cylinders	4
Bore and Stroke	4.13 x 5 inches 105 x 127 mm
Horsepower net intermittent	
Gross intermittent @ 2400 rpm	86 hp / 64 kW
Net intermittent @ 2400 rpm	83 hp / 62 kW
Firing order	1 - 3 - 4 - 2
Low idle	1300 rpm 312 Hz
High idle	2350 rpm 572 Hz
Compression ratio	18.2:1
Compression pressure (psi or bar) of the lowest cylinder must be at least 75% of the highest cylinder	
Governor	centrifugal mechanical
Valve Clearance, cold	
Intake	0.008 in 0.2 mm
Exhaust	0.018 in 0.45 mm

Lubrication system

Oil pressure, hot (@ 2000 rpm)	40 to 60 psi 2.8 to 4.1 bar
Oil capacity (including filter)	7.3 quarts 6.9 liters

Oil viscosity requirements

Below 68°F / 20°C	5W-20
10°F to 104°F / -12°C to 40°C	10W-40
Above 14°F / -10°C	15W-40

Unit ships with 15W-40. Extreme operating temperatures may require the use of alternative engine oils. For oil requirements, refer to the Engine Operator Manual for your engine.

Oil Pressure switch

Installation torque	8 - 18 ft-lbs 11 - 24 Nm
Pressure switch point	8 psi 0.55 bar

Fuel injection system

Injection pump make	Bosch
Injector opening pressure	2200 psi 152 bar

Fuel requirement

For fuel requirements, refer to the engine Operator Manual for your engine.

Continuous improvement of our products is a Genie policy. Product specifications are subject to change without notice or obligation.

Specifications

Perkins 1104C-44 cont.

Starter motor

Current draw, normal load	140 - 200A
Cranking speed	200 - 250 rpm

Battery – Auxiliary power units

Type	6V DC
Quantity	2
Battery capacity, maximum	285 AH
Reserve capacity @ 25A rate	745 minutes

Battery – Engine starting and control system

Type	12V DC, Group 31
Quantity	1
Battery capacity, maximum	1000A
Reserve capacity @ 25A rate	200 Minutes

Engine coolant

Capacity	14 quarts 13.2 liters
----------	--------------------------

Coolant temperature switch

Installation torque	8 - 18 ft-lbs 11 - 24 Nm
Temperature switch point	230°F 110°C

Alternator output	85A @ 13.8V DC
-------------------	----------------

Fan belt deflection	3/8 inch 9.5 mm
---------------------	--------------------

Continuous improvement of our products is a Genie policy. Product specifications are subject to change without notice or obligation.

Specifications

Perkins 804D-33T

Displacement	203 cu. in 3.33 liters
Number of cylinders	4
Bore and Stroke	3.7 x 4.72 inches 94 x 120 mm
Horsepower net intermittent Gross intermittent @ 2200 rpm	83 hp / 62 kW
Induction system	turbocharged
Firing order	1 - 3 - 4 - 2
Low idle	1300 rpm 316 Hz
High idle	2350 rpm 572 Hz
Compression ratio	19.5:1
Compression pressure (psi or bar) of the lowest cylinder must be at least 75% of the highest cylinder	
Governor	centrifugal mechanical
Valve Clearance, cold	
Intake	0.0098 in 0.25 mm
Exhaust	0.0098 in 0.25 mm

Lubrication system

Oil pressure, hot (@ 2000 rpm)	40 to 60 psi 2.8 to 4.1 bar
Oil capacity (including filter)	10.6 quarts 10 liters

Oil viscosity requirements

Below 86°F / 30°C	5W-20
-4°F to 104°F / -20°C to 40°C	10W-30
Above 14°F / -10°C	15W-40

Unit ships with 15W-40. Extreme operating temperatures may require the use of alternative engine oils. For oil requirements, refer to the Engine Operator Manual for your engine.

Oil Pressure switch

Installation torque	8 - 18 ft-lbs 11 - 24 Nm
Pressure switch point	8 psi 0.55 bar

Fuel injection system

Injection pump make	Bosch
Injector opening pressure	2200 psi 152 bar

Fuel requirement

For fuel requirements, refer to the engine Operator Manual for your engine.

Continuous improvement of our products is a Genie policy. Product specifications are subject to change without notice or obligation.

Specifications

Perkins 804D-33T cont.

Starter motor

Current draw, normal load	200A
Cranking speed	250 rpm

Battery – Auxiliary power units

Type	6V DC
Quantity	2
Battery capacity, maximum	285 AH
Reserve capacity @ 25A rate	745 minutes

Battery – Engine starting and control system

Type	12V DC, Group 31
Quantity	1
Battery capacity, maximum	1000A
Reserve capacity @ 25A rate	200 Minutes

Engine coolant

Capacity	12.5 quarts 11.8 liters
----------	----------------------------

Coolant temperature switch

Installation torque	8 - 18 ft-lbs 11 - 24 Nm
Temperature switch point	230°F 110°C

Alternator output	90A @ 12V DC
--------------------------	--------------

Fan belt deflection	3/8 to 1/2 inch 9.5 to 12.5 mm
----------------------------	-----------------------------------

Continuous improvement of our products is a Genie policy. Product specifications are subject to change without notice or obligation.

Specifications

Machine Torque Specifications

Platform Rotator

1-8 center bolt, GR 5	480 ft-lbs 651 Nm
3/8 -16 bolts, GR 8	44 ft-lbs 60 Nm

Turntable rotate assembly

Rotate bearing mounting bolts, lubricated (3/4 -10 SHC)	320 ft-lbs 434 Nm
Rotate bearing mounting bolts, lubricated (5/8 -11 SHC)	180 ft-lbs 244 Nm
Rotate drive hub mounting bolts, lubricated	80 ft-lbs 108 Nm
Drive motor mounting bolts, dry	75 ft-lbs 102 Nm
Drive motor mounting bolts, lubricated	56 ft-lbs 76 Nm
Backlash plate mounting bolts, lubricated	320 ft-lbs 434 Nm

Drive motors and hubs

Drive hub mounting bolts, lubricated	180 ft-lbs 217 Nm
Drive motor mounting bolts, dry	75 ft-lbs 102 Nm
Drive motor mounting bolts, lubricated	56 ft-lbs 76 Nm

Engine vibration isolators

Mounting bolts, dry	60 ft-lbs 81 Nm
Mounting bolts, lubricated	45 ft-lbs 61 Nm

Continuous improvement of our products is a Genie policy. Product specifications are subject to change without notice or obligation.

Specifications

Hydraulic Hose and Fitting Torque Specifications

Your machine is equipped with Parker Seal-Lok™ ORFS or 37° JIC fittings and hose ends. Genie specifications require that fittings and hose ends be torqued to specification when they are removed and installed or when new hoses or fittings are installed.

Seal-Lok™ Fittings (hose end - ORFS)	
SAE Dash Size	Torque
-4	10 ft-lbs / 13.6 Nm
-6	30 ft-lbs / 40.7 Nm
-8	40 ft-lbs / 54.2 Nm
-10	60 ft-lbs / 81.3 Nm
-12	85 ft-lbs / 115 Nm
-16	110 ft-lbs / 150 Nm
-20	140 ft-lbs / 190 Nm
-24	180 ft-lbs / 245 Nm

JIC 37° Fittings (swivel nut or hose connection)		
SAE Dash Size	Thread Size	Flats
-4	7/16-20	2
-6	9/16-18	1 ¼
-8	3/4-16	1
-10	7/8-14	1
-12	1 1/16-12	1
-16	1 5/16-12	1
-20	1 5/8-12	1
-24	1 7/8-12	1

SAE O-ring Boss Port

(tube fitting - installed into Aluminum)
(all types)

SAE Dash Size	Torque
-4	14 ft-lbs / 19 Nm
-6	23 ft-lbs / 31.2 Nm
-8	36 ft-lbs / 54.2 Nm
-10	62 ft-lbs / 84 Nm
-12	84 ft-lbs / 114 Nm
-16	125 ft-lbs / 169.5 Nm
-20	151 ft-lbs / 204.7 Nm
-24	184 ft-lbs / 249.5 Nm

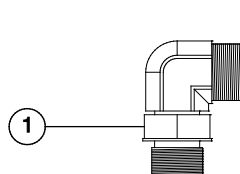

Adjustable Fitting



Non-adjustable fitting

1 jam nut

SAE O-ring Boss Port

(tube fitting - installed into Steel)

SAE Dash Size	Torque
-4	ORFS / 37° (Adj) 15 ft-lbs / 20.3 Nm ORFS (Non-adj) 26 ft-lbs / 35.3 Nm 37° (Non-adj) 22 ft-lbs / 30 Nm
-6	ORFS (Adj / Non-adj) 35 ft-lbs / 47.5 Nm 37° (Adj / Non-adj) 29 ft-lbs / 39.3 Nm
-8	ORFS (Adj / Non-adj) 60 ft-lbs / 81.3 Nm 37° (Adj / Non-adj) 52 ft-lbs / 70.5 Nm
-10	ORFS (Adj / Non-adj) 100 ft-lbs / 135.6 Nm 37° (Adj / Non-adj) 85 ft-lbs / 115.3 Nm
-12	(All types) 135 ft-lbs / 183 Nm
-16	(All types) 200 ft-lbs / 271.2 Nm
-20	(All types) 250 ft-lbs / 339 Nm
-24	(All types) 305 ft-lbs / 413.5 Nm

Specifications

Torque Procedure

Seal-Lok™ fittings

- 1 Replace the O-ring. The O-ring must be replaced anytime the seal has been broken. The O-ring cannot be re-used if the fitting or hose end has been tightened beyond finger tight.

Note: The O-ring in Parker Seal Lok™ fittings and hose end are custom-size O-rings. They are not standard size O-rings. They are available in the O-ring field service kit (Genie part number 49612).

- 2 Lubricate the O-ring before installation.
- 3 Be sure the O-ring face seal is seated and retained properly.
- 4 Position the tube and nut squarely on the face seal end of the fitting, and tighten the nut finger tight.
- 5 Tighten the nut or fitting to the appropriate torque. Refer to the appropriate torque chart in this section.
- 6 Operate all machine functions and inspect the hose, fittings and related components to confirm there are no leaks.

JIC 37° fittings

- 1 Align the tube flare (hex nut) against the nose of the fitting body (body hex fitting) and tighten the hex nut to the body hex fitting to hand tight, approximately 30 in-lbs / 3.4 Nm.
- 2 Using a permanent ink marker, make a reference mark on one the flats of the hex nut and continue the mark onto the body of the hex fitting. Refer to Illustration 1.

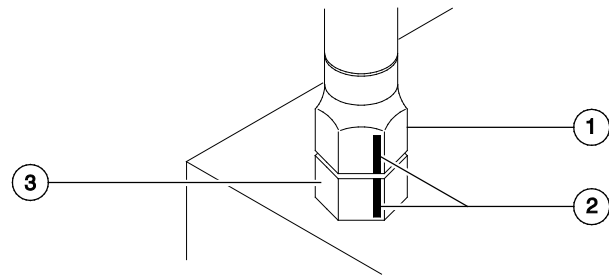

Illustration 1

- 1 hex nut
- 2 reference mark
- 3 body hex fitting

Specifications

- 3 Working clockwise on the body hex fitting, make a second mark with a permanent ink marker to indicate the proper tightening position. Refer to Illustration 2.

Note: Use the JIC 37° Fitting table in this section to determine the correct number of flats, for the proper tightening position.

Note: The marks indicate the correct tightening positions have been determined. Use the second mark on the body hex fitting to properly tighten the joint after it has been loosened.

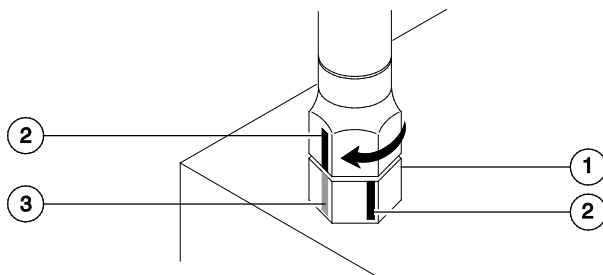







Illustration 2

- 1 body hex fitting
- 2 reference mark
- 3 second mark

- 4 Tighten the hex nut until the mark on the hex nut is aligned with the second mark on the body hex fitting.
- 5 Operate all machine functions and inspect the hose, fittings and related components to confirm there are no leaks.

Specifications

SAE FASTENER TORQUE CHART											
• This chart is to be used as a guide only unless noted elsewhere in this manual •											
SIZE	THREAD	Grade 5 				Grade 8 				A574 High Strength Black Oxide Bolts	
		LUBED		DRY		LUBED		DRY		LUBED	
		in-lbs	Nm	in-lbs	Nm	in-lbs	Nm	in-lbs	Nm	in-lbs	Nm
1/4	20	80	9	100	11.3	110	12.4	140	15.8	130	14.7
	28	90	10.1	120	13.5	120	13.5	160	18	140	15.8
		LUBED		DRY		LUBED		DRY		LUBED	
		ft-lbs	Nm	ft-lbs	Nm	ft-lbs	Nm	ft-lbs	Nm	ft-lbs	Nm
5/16	18	13	17.6	17	23	18	24	25	33.9	21	28.4
	24	14	19	19	25.7	20	27.1	27	36.6	24	32.5
3/8	16	23	31.2	31	42	33	44.7	44	59.6	38	51.5
	24	26	35.2	35	47.4	37	50.1	49	66.4	43	58.3
7/16	14	37	50.1	49	66.4	50	67.8	70	94.7	61	82.7
	20	41	55.5	55	74.5	60	81.3	80	108.4	68	92.1
1/2	13	57	77.3	75	101.6	80	108.4	110	149	93	126
	20	64	86.7	85	115	90	122	120	162	105	142
9/16	12	80	108.4	110	149	120	162	150	203	130	176
	18	90	122	120	162	130	176	170	230	140	189
5/8	11	110	149	150	203	160	217	210	284	180	244
	18	130	176	170	230	180	244	240	325	200	271
3/4	10	200	271	270	366	280	379	380	515	320	433
	16	220	298	300	406	310	420	420	569	350	474
7/8	9	320	433	430	583	450	610	610	827	510	691
	14	350	474	470	637	500	678	670	908	560	759
1	8	480	650	640	867	680	922	910	1233	770	1044
	12	530	718	710	962	750	1016	990	1342	840	1139
1 1/8	7	590	800	790	1071	970	1315	1290	1749	1090	1477
	12	670	908	890	1206	1080	1464	1440	1952	1220	1654
1 1/4	7	840	1138	1120	1518	1360	1844	1820	2467	1530	2074
	12	930	1260	1240	1681	1510	2047	2010	2725	1700	2304
1 1/2	6	1460	1979	1950	2643	2370	3213	3160	4284	2670	3620
	12	1640	2223	2190	2969	2670	3620	3560	4826	3000	4067

METRIC FASTENER TORQUE CHART																
• This chart is to be used as a guide only unless noted elsewhere in this manual •																
Size (mm)	Class 4.6 				Class 8.8 				Class 10.9 				Class 12.9 			
	LUBED		DRY		LUBED		DRY		LUBED		DRY		LUBED		DRY	
	in-lbs	Nm	in-lbs	Nm	in-lbs	Nm	in-lbs	Nm	in-lbs	Nm	in-lbs	Nm	in-lbs	Nm	in-lbs	Nm
5	16	1.8	21	2.4	41	4.63	54	6.18	58	6.63	78	8.84	68	7.75	91	10.3
6	19	3.05	36	4.07	69	7.87	93	10.5	100	11.3	132	15	116	13.2	155	17.6
7	45	5.12	60	6.83	116	13.2	155	17.6	167	18.9	223	25.2	1.95	22.1	260	29.4
	LUBED		DRY		LUBED		DRY		LUBED		DRY		LUBED		DRY	
	ft-lbs	Nm	ft-lbs	Nm	ft-lbs	Nm	ft-lbs	Nm	ft-lbs	Nm	ft-lbs	Nm	ft-lbs	Nm	ft-lbs	Nm
8	5.4	7.41	7.2	9.88	14	19.1	18.8	25.5	20.1	27.3	26.9	36.5	23.6	32	31.4	42.6
10	10.8	14.7	14.4	19.6	27.9	37.8	37.2	50.5	39.9	54.1	53.2	72.2	46.7	63.3	62.3	84.4
12	18.9	25.6	25.1	34.1	48.6	66	64.9	88	69.7	94.5	92.2	125	81	110	108	147
14	30.1	40.8	40	54.3	77.4	105	103	140	110	150	147	200	129	175	172	234
16	46.9	63.6	62.5	84.8	125	170	166	226	173	235	230	313	202	274	269	365
18	64.5	87.5	86.2	117	171	233	229	311	238	323	317	430	278	377	371	503
20	91	124	121	165	243	330	325	441	337	458	450	610	394	535	525	713
22	124	169	166	225	331	450	442	600	458	622	612	830	536	727	715	970
24	157	214	210	285	420	570	562	762	583	791	778	1055	682	925	909	1233



Repair Procedures



Observe and Obey:

- Repair procedures shall be completed by a person trained and qualified on the repair of this machine.
- Immediately tag and remove from service a damaged or malfunctioning machine.
- Repair any machine damage or malfunction before operating the machine.

Before Repairs Start:

- Read, understand and obey the safety rules and operating instructions in the appropriate operator's manual on your machine.
- Be sure that all necessary tools and parts are available and ready for use.
- Use only Genie approved replacement parts.
- Read each procedure completely and adhere to the instructions. Attempting shortcuts may produce hazardous conditions.

Machine Configuration:

- Unless otherwise specified, perform each repair procedure with the machine in the following configuration:
 - Machine parked on a firm, level surface
 - Key switch in the off position with the key removed
 - The red Emergency Stop button in the off position at both the ground and platform controls
 - Wheels chocked
 - All external AC power supply disconnected from the machine
 - Boom in the stowed position
 - Turntable secured with the turntable rotation lock

Repair Procedures

About This Section

Most of the procedures in this section should only be performed by trained service professional in a suitably equipped workshop. Select the appropriate repair procedure after troubleshooting the problem.

Perform disassembly procedures to the point where repairs can be completed. Then to re-assemble, perform the disassembly steps in reverse order.

Symbols Legend



Safety alert symbol—used to alert personnel to potential personal injury hazards. Obey all safety messages that follow this symbol to avoid possible injury or death.



Indicates a imminently hazardous situation which, if not avoided, will result in death or serious injury.



Indicates a potentially hazardous situation which, if not avoided, could result in death or serious injury.



Indicates a potentially hazardous situation which, if not avoided, may cause minor or moderate injury.



Indicates a potentially hazardous situation which, if not avoided, may result in property damage.

- Indicates that a specific result is expected after performing a series of steps.
- ⊗ Indicates that an incorrect result has occurred after performing a series of steps.

Platform Controls

Platform Controls

The platform controls contains two printed circuit boards:

The LED circuit board is mounted to the underside of the control box lid which contains the LEDs. The LED circuit board sends the input from the operator to the platform controls circuit board (PCON). The circuit board (PCON) sends the data to the turntable control box (TCON) for processing.

The platform controls ECM circuit board communicates with the turntable controls. The joystick controllers at the platform controls utilize Hall Effect technology and require no adjustment. The operating parameters of the joysticks are stored in memory at the turntable controls. If a joystick controller error occurs or if a joystick is replaced, it will need to be calibrated before that particular machine function will operate. Refer to Repair Procedure, *How to Calibrate a Joystick Controller*.

Each joystick controller should operate smoothly and provide proportional speed control over its entire range of motion.

For further information or assistance, consult Genie Product Support.

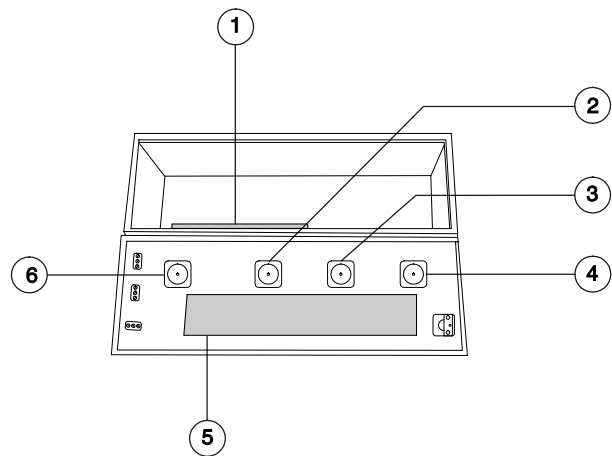

- 1 platform controls ALC-1000 circuit board
- 2 jib boom up/down, jib boom extend/retract and platform rotate left right joystick
- 3 secondary boom up/extend and down/retract joystick
- 4 drive/steer joystick controller
- 5 LED circuit board
- 6 primary boom up/down, primary boom extend/retract and turntable rotate left/right joystick

Platform Controls

1-1 Platform Circuit Board

⚠ WARNING Electrocutation/burn hazard. Contact with electrically charged circuits could result in death or serious injury. Remove all rings, watches and other jewelry.

Note: When the platform circuit board is replaced, jib bellcrank and platform level will need to be calibrated. Refer to Repair Procedures, *How to Calibrate the Jib Boom Bellcrank Angle Sensor* or *How to Calibrate the Platform Level Sensor*.

How to Remove the Circuit Board

- 1 Push in the red Emergency Stop button to the off position at both the ground and platform controls.
- 2 Locate the cables that connect to the bottom of the control box. Number each cable and its location at the control box.
- 3 Disconnect the cables from the bottom of the platform control box.
- 4 Remove the control cable receptacle retaining fasteners from the bottom of the platform control box.
- 5 Remove the platform control box lid retaining fasteners. Open the control box lid.
- 6 Locate the circuit board mounted to the inside of the platform control box.
- 7 Attach a grounded wrist strap to the ground screw inside the control box.

⚠ WARNING Electrocutation/burn hazard. Contact with electrically charged circuits could result in death or serious injury. Remove all rings, watches and other jewelry.

NOTICE Component damage hazard. Electrostatic discharge (ESD) can damage printed circuit board components. Maintain firm contact with a metal part of the machine that is grounded at all times when handling printed circuit boards OR use a grounded wrist strap.

- 8 Tag and carefully disconnect the wire connectors from the circuit board.
- 9 Tag and disconnect the ribbon cable from the LED circuit board.
- 10 Remove the circuit board mounting fasteners.
- 11 Carefully remove the circuit board from the control box.

Platform Controls

How to Remove the LED Circuit Board

- 1 Push in the red Emergency Stop button to the off position at both the ground and platform controls.
- 2 Remove the platform control box lid retaining fasteners. Open the control box lid.
- 3 Locate the circuit board mounted to the inside of the platform control box.

⚠ WARNING Electrocutation/burn hazard. Contact with electrically charged circuits could result in death or serious injury. Remove all rings, watches and other jewelry.

NOTICE Component damage hazard. Electrostatic discharge (ESD) can damage printed circuit board components. Maintain firm contact with a metal part of the machine that is grounded at all times when handling printed circuit boards OR use a grounded wrist strap.

- 4 Tag and carefully disconnect the ribbon cables from the membrane circuit board.
- 5 Remove the circuit board mounting fasteners.
- 6 Carefully remove the LED circuit board from the platform control box lid. Do not lose the plastic spacers.

Note: When installing the LED circuit board, be sure the plastic spacers are installed between the circuit board and the control box lid.

Platform Controls

1-2 Membrane Decal

How to Replace the Membrane Decal

The membrane decal is a special decal that consists of a decal with an electronic membrane on the backside. The membrane contains touch sensitive areas that, when pushed, activate the machine functions. The membrane contains touch sensitive areas that activate the machine functions.

- 1 Push in the red Emergency Stop button to the off position at both the ground and platform controls.
- 2 Remove the platform control box lid retaining fasteners. Open the control box lid.
- 3 Tag and carefully disconnect the two ribbon cables from the membrane circuit board.

⚠ WARNING Electrocutation/burn hazard. Contact with electrically charged circuits could result in death or serious injury. Remove all rings, watches and other jewelry.

NOTICE Component damage hazard. Electrostatic discharge (ESD) can damage printed circuit board components. Maintain firm contact with a metal part of the machine that is grounded at all times when handling printed circuit boards OR use a grounded wrist strap.

- 4 Close the control box lid.
- 5 Remove the platform controls decal from the platform control box.
- 6 Carefully remove the membrane decal from the control box lid while guiding the ribbon cables out of the control box lid.
- 7 Remove any decal adhesive from the control box lid with a mild solvent.

Note: Do not allow any solvent to come in contact with the membrane circuit board.

- 8 Install the new membrane decal while guiding the ribbon cables through the control box lid.

Note: Be sure that all LED locations on the membrane decal align with the LEDs on the membrane circuit board.

- 9 Install a new platform controls decal over the membrane decal.
- 10 Open the control box lid and carefully connect the ribbon cables from the membrane decal to the membrane circuit board.

Platform Controls

1-3 Joysticks

How to Calibrate a Joystick

The joystick controllers on this machine utilize digital Hall Effect technology for proportional control. If a joystick controller is disconnected or replaced, it must be calibrated before that particular machine function will operate.

Note: The joystick must be calibrated before the threshold, max-out or ramping can be set.

Note: After each joystick is calibrated, check the display at the ground control box. There should be no calibration faults shown on the display. If calibration faults exist, repeat procedure for that joystick controlled function.

Note: Perform this procedure with the engine off.

Note: Use the following chart to identify the description of each LCD screen control button used in this procedure.



Plus



Minus



Previous



Enter

Drive functions:

- 1 Turn the key switch to the off position.
 - 2 Press and hold the **enter** button on the ground control panel while turning the key switch to platform controls. Hold the **enter** button for approximately 5 seconds.
 - 3 Press the **minus** button twice, then press the **enter** button twice.
 - 4 Use the scroll button to scroll through the menu until DELETE DRIVE JOYSTICK DEFAULTS is displayed.
 - 5 Press the **plus** button to select YES, then press the **enter** button.
 - 6 Do not start the engine.
 - 7 Locate the drive/steer joystick.
 - 8 Move the drive/steer joystick full stroke in the forward direction and hold for 5 seconds, then return to the center or neutral position.
 - 9 Move the drive/steer joystick full stroke in the reverse direction and hold for 5 seconds, then return to the center or neutral position.
- ⊙ Result: The alarm at the ground controls should sound for a successful calibration.

Platform Controls

Steer functions:

- 1 Turn the key switch to the off position.
 - 2 Press and hold the **enter** button on the ground control panel while turning the key switch to platform controls. Hold the **enter** button for approximately 5 seconds.
 - 3 Press the **minus** button twice, then press the **enter** button twice.
 - 4 Use the scroll button to scroll through the menu until DELETE STEER JOYSTICK DEFAULTS is displayed.
 - 5 Press the **plus** button to select YES, then press the **enter** button.
 - 6 Do not start the engine.
 - 7 Locate the drive/steer joystick.
 - 8 Move the drive/steer joystick or thumb rocker switch (if equipped) full stroke in the left direction and hold for 5 seconds, then return to the center or neutral position.
 - 9 Move the drive/steer joystick or thumb rocker switch (if equipped) full stroke in the right direction and hold for 5 seconds, then return to the center or neutral position.
- ⊙ Result: The alarm at the ground controls should sound for a successful calibration.

Secondary boom up/down and extend/retract functions:

- 1 Turn the key switch to the off position.
 - 2 Press and hold the **enter** button on the ground control panel while turning the key switch to platform controls. Hold the **enter** button for approximately 5 seconds.
 - 3 Press the **minus** button twice, then press the **enter** button twice.
 - 4 Use the scroll button to scroll through the menu until DELETE SECONDARY BOOM JOYSTICK DEFAULTS is displayed.
 - 5 Press the **plus** button to select YES, then press the **enter** button.
 - 6 Do not start the engine.
 - 7 Locate the secondary boom up/down and extend/retract joystick.
 - 8 Move the secondary boom up/down and extend/retract joystick full stroke in the up/extend direction and hold for 5 seconds, then return to the center or neutral position.
 - 9 Move the secondary boom up/down and extend/retract joystick full stroke in the down/retract direction and hold for 5 seconds, then return to the center or neutral position.
- ⊙ Result: The alarm at the ground controls should sound for a successful calibration.

Platform Controls

Primary boom extend/retract functions:

- 1 Turn the key switch to the off position.
 - 2 Press and hold the **enter** button on the ground control panel while turning the key switch to platform controls. Hold the **enter** button for approximately 5 seconds.
 - 3 Press the **minus** button twice, then press the **enter** button twice.
 - 4 Use the scroll button to scroll through the menu until DELETE PRIMARY BOOM EXTEND/RETRACT JOYSTICK DEFAULTS is displayed.
 - 5 Press the **plus** button to select YES, then press the **enter** button.
 - 6 Do not start the engine.
 - 7 Locate the thumb rocker switch on top of the primary boom/turntable rotate joystick.
 - 8 Move the primary boom extend/retract thumb rocker switch full stroke in the extend direction and hold for 5 seconds, then return to the center or neutral position.
 - 9 Move the primary boom extend/retract thumb rocker switch full stroke in the retract direction and hold for 5 seconds, then return to the center or neutral position.
- ⦿ Result: The alarm at the ground controls should sound for a successful calibration.

Primary boom up/down functions:

- 1 Turn the key switch to the off position.
 - 2 Press and hold the **enter** button on the ground control panel while turning the key switch to platform controls. Hold the **enter** button for approximately 5 seconds.
 - 3 Press the **minus** button twice, then press the **enter** button twice.
 - 4 Use the scroll button to scroll through the menu until DELETE PRIMARY BOOM UP/DOWN JOYSTICK DEFAULTS is displayed.
 - 5 Press the **plus** button to select YES, then press the **enter** button.
 - 6 Do not start the engine.
 - 7 Locate the primary boom/turntable rotate joystick.
 - 8 Move the boom/turntable rotate joystick full stroke in the up direction and hold for 5 seconds, then return to the center or neutral position.
 - 9 Move the boom/turntable rotate joystick full stroke in the down direction and hold for 5 seconds, then return to the center or neutral position.
- ⦿ Result: The alarm at the ground controls should sound for a successful calibration.

Platform Controls

Jib boom up/down functions:

- 1 Turn the key switch to the off position.
 - 2 Press and hold the **enter** button on the ground control panel while turning the key switch to platform controls. Hold the **enter** button for approximately 5 seconds.
 - 3 Press the **minus** button twice, then press the **enter** button twice.
 - 4 Use the scroll button to scroll through the menu until RESET JIB BOOM UP/DOWN JOYSTICK DEFAULTS is displayed.
 - 5 Press the **plus** button to select YES, then press the **enter** button.
 - 6 Do not start the engine.
 - 7 Locate the jib boom joystick.
 - 8 Move the jib boom joystick full stroke in the up direction and hold for 5 seconds, then return to the center or neutral position.
 - 9 Move the jib boom joystick full stroke in the down direction and hold for 5 seconds, then return to the center or neutral position.
- ⦿ Result: The alarm at the ground controls should sound for a successful calibration.

Turntable rotate functions:

- 1 Turn the key switch to the off position.
 - 2 Press and hold the **enter** button on the ground control panel while turning the key switch to platform controls. Hold the **enter** button for approximately 5 seconds.
 - 3 Press the **minus** button twice, then press the **enter** button twice.
 - 4 Use the scroll button to scroll through the menu until DELETE TURNTABLE ROTATE JOYSTICK DEFAULTS is displayed.
 - 5 Press the **plus** button to select YES, then press the **enter** button.
 - 6 Do not start the engine.
 - 7 Locate the primary boom/turntable rotate joystick.
 - 8 Move the boom/turntable joystick full stroke in the left direction and hold for 5 seconds, then return to the center or neutral position.
 - 9 Move the boom/turntable joystick full stroke in the right direction and hold for 5 seconds, then return to the center or neutral position.
- ⦿ Result: The alarm at the ground controls should sound for a successful calibration.

Platform Controls

How to Reset a Proportional Valve Coil Default

Note: Use the following chart to identify the description of each LCD screen control button used in this procedure.



Plus

Minus

Previous

Enter

Note: This procedure only needs to be performed if a proportional valve has been replaced.

Note: After the valve coil defaults have been set, each machine function threshold and default function speed must be set. Refer to Repair Procedure, *How to Set the Function Thresholds and Default Function Speeds*.

- 1 Turn the key switch to the off position.
- 2 Press and hold the **enter** button on the ground control panel while turning the key switch to platform controls. Hold the **enter** button for approximately 5 seconds.
- 3 Press the **minus** button twice, then press the **enter** button twice.
- 4 Use the **previous** button to scroll through the menu until the function valve that needs to be reset is displayed. Press the **plus** button to select yes, then press the **enter** button to save the setting.
- 5 Press the **enter** or **previous** button on the LCD screen until EXIT is displayed.
- 6 Press the **plus** button or **minus** button to select YES and then press the **enter** button.

How to Set the Function Thresholds and Default Functions Speeds

Note: Before the threshold and default function speeds can be set, the boom function proportional valve coil defaults must be set first. Refer to Repair Procedure, *How to Reset a Proportional Valve Coil Default*.

Note: If a boom function proportional valve coil has not been replaced and just want to reset the function speed to original factory settings, proceed to Function speeds procedure.

- 1 Start the engine from the platform controls.
- 2 Press down the foot switch.

Note: Be sure the engine rpm is set to foot switch activated high idle.

Function threshold:

- 3 Select a joystick controlled function that needs to have the threshold set.
- 4 Slowly move the joystick off center in either direction just until the machine function starts to move, then move the joystick very slowly towards the neutral or center position just before the machine function stops. Do not let go of the joystick.
- 5 While holding the joystick in position, press the engine start button at the platform controls to set the joystick controller threshold.

Platform Controls

- 6 Slowly move the joystick off center in the opposite direction just until the machine function starts to move, then move the joystick very slowly towards the neutral or center position just before the machine function stops. Do not let go of the joystick.
- 7 While holding the joystick in position, press the engine start button at the platform controls to set the joystick controller threshold.
- 8 Repeat steps for each joystick controlled machine function:
 - Primary boom up/down
 - Turntable rotate left/right
 - Primary boom extend/retract
 - Secondary up/down and extend/retract
 - Drive forward/reverse
- 9 Once the threshold has been set, press and hold the engine start button until the engine shuts off. Do not press the red Emergency Stop button.

Note: Approximately 3 seconds after the engine shuts off, the alarm at the ground controls will sound to indicate the settings are being saved in memory.

- 10 At the ground controls, turn the key switch to the off position, wait a moment and then turn the key switch to platform controls.
- 11 Check the display at the ground controls to be sure there are no calibration faults.

Note: There should be no calibration faults shown on the display. If calibration faults exist, repeat this procedure.

Function speeds:

Note: Be sure the machine is in the stowed position and the boom is rotated between the circle end tires.

Note: Perform this procedure with the machine on a firm, level surface that is free of obstructions.

Note: Unless the LCD screen displays NOT CALIBRATED, it will be necessary to enter the valve calibration menu.

- 12 Start the engine from the platform controls.
- 13 Select a function that needs the function speed set.
- 14 **Primary boom up/down and extend/retract functions:** Move the joystick full stroke in the up or extend direction. When the alarm sounds, move the joystick in the opposite direction full stroke until the alarm sounds again. Return the joystick to center.

Secondary boom up and down functions:

Starting from the stowed position, move the joystick full stroke in the up direction. When the alarm sounds, move the joystick in the down direction full stroke until the alarm sounds again. Return the joystick to center.

Turntable rotate function, fully retracted:

Move the rotate joystick full stroke in either the left or right direction until the alarm sounds. Return the joystick to center.

Platform Controls

Turntable rotate function, primary boom extended: Extend the primary boom approximately 4 ft / 1.2 m. Move the rotate joystick full stroke in either the left or right direction until the alarm sounds. Return the joystick to center.

Turntable rotate function, primary and jib booms extended: With the primary boom extended approximately 4 ft / 1.2 m, extend the jib boom approximately 1 ft / 0.3 m. Move the rotate joystick full stroke in either the left or right direction until the alarm sounds. Return the joystick to center.

- 15 Once the function speeds have been set, press and hold the engine start button until the engine shuts off. Do not press the red Emergency Stop button.

Note: Approximately 3 seconds after the engine shuts off, the alarm at the ground controls will sound to indicate the settings are being saved in memory.

- 16 At the ground controls, turn the key switch to the off position, wait a moment and then turn the key switch to platform controls.
- 17 Check the display at the ground controls to be sure there are no calibration faults.

Note: There should be no calibration faults shown on the display. If calibration faults exist, repeat this procedure.

How to Adjust the Function Speeds

Note: Perform this procedure with the boom in the stowed position.

Note: Use the following chart to identify the description of each LCD screen control button used in this procedure.



Plus Minus Previous Enter

- 1 Pull out the red Emergency Stop button to the on position at both the ground and platform controls.
- 2 Press and hold the **enter** button on the ground control panel while turning the key switch to platform controls. Hold the **enter** button for approximately 5 seconds.
- 3 Press the **plus** button twice, then press the **minus** button twice.
- 4 Press the **previous** button until the function to be adjusted is displayed.
- 5 Press the **plus** button to increase the speed or press the **minus** button to decrease the speed.

Platform Controls

- 6 Press the **enter** button to save the setting in memory.
- 7 Press the **enter** or **previous** button on the LCD screen until EXIT is displayed.
- 8 Press the **plus** button or **minus** button to select YES and then press the **enter** button.
- 9 Continue to perform this procedure until the machine function speed meets specification. Refer to Specifications, *Performance Specifications*.

How to Adjust the Function Ramp Rate Setting

The ramp rate setting of a joystick controls the time at which it takes for the joystick to reach maximum output, when moved out of the neutral position. The ramp rate settings of a joystick can be changed to compensate for hydraulic pump wear to maintain peak performance from the machine.

Note: Perform this procedure with the boom in the stowed position.

Note: Use the following chart to identify the description of each LCD screen control button used in this procedure.



Plus Minus Previous Enter

- 1 Pull out the red Emergency Stop button to the on position at both the ground and platform controls.
- 2 Press and hold the **enter** button on the ground control panel while turning the key switch to platform controls. Hold the **enter** button for approximately 5 seconds.
- 3 Press the **plus** button twice, then press the **previous** button twice.

Platform Controls

- 4 Press the **previous** button until the function to be adjusted is displayed.
- 5 Press the **plus** button to increase the ramp rate or press the **minus** button to decrease the ramp rate.
- 6 Press the **enter** button to save the setting in memory.
- 7 Press the **enter** or **previous** button on the LCD screen until EXIT is displayed.
- 8 Press the **plus** button or **minus** button to select YES and then press the **enter** button.

Platform Components

2-1 Platform Leveling Cylinder

The platform leveling cylinder keeps the platform level through the entire range of boom motion. The platform is maintained level to the turntable. To accomplish this, the ECM at the ground controls compares the difference in readings between the platform angle sensor and the turntable level sensor, which then sends a signal to the platform controls to open or close the appropriate platform level proportional valve on the platform manifold to maintain a level platform. The platform leveling cylinder is equipped with counterbalance valves to prevent movement in the event of a hydraulic line failure.

How to Remove the Platform Leveling Cylinder

Note: When removing a hose assembly or fitting, the O-ring (if equipped) on the fitting and/or hose end must be replaced. All connections must be torqued to specification during installation. Refer to Specifications, *Hydraulic Hose and Fitting Torque Specifications*.

- 1 Extend the jib boom until the platform leveling cylinder barrel-end pivot pin is accessible.
- 2 Raise the jib boom slightly and place blocks under the platform.
- 3 Lower the jib boom until the platform is resting on the blocks just enough to support the platform.

Note: Do not rest the entire weight of the boom on the blocks.

- 4 Place a block under the platform leveling cylinder for support.
- 5 Remove the external snap rings from the barrel-end pivot pin. Use a soft metal drift to remove the barrel-end pivot pin.
- 6 Support the rod end of the platform level cylinder.
- 7 Remove the pin retaining fasteners from the platform leveling cylinder rod-end pivot pin. Use a soft metal drift to remove the barrel-end pivot pin.
- 8 Carefully pull the platform leveling cylinder out of the boom to access the hydraulic hoses.
- 9 Tag, disconnect and plug the hydraulic hoses from the platform leveling cylinder. Cap the fittings on the cylinder.

⚠ WARNING

Bodily injury hazard. Spraying hydraulic oil can penetrate and burn skin. Loosen hydraulic connections very slowly to allow the oil pressure to dissipate gradually. Do not allow oil to squirt or spray.

- 10 Remove the platform leveling cylinder from the machine.

⚠ CAUTION

Crushing hazard. The platform leveling cylinder may fall if not properly supported when removed from the machine.

Platform Components

2-2

Platform Rotator

The platform rotator is a hydraulically activated helical gear assembly used to rotate the platform 160 degrees.

How to Remove the Platform Rotator

NOTICE Component damage hazard. Mark the platform mounting weldment and the rotator flange before removing the platform mounting weldment. The platform mounting weldment must be replaced in the exact same position on the rotator flange as it was before removal. If a new rotator is installed or the rotator is disassembled, proper alignment can be achieved by rotating the rotator all the way to the left and then installing the platform mounting weldment all the way in the left position.

Note: When removing a hose assembly or fitting, the O-ring (if equipped) on the fitting and/or hose end must be replaced. All connections must be torqued to specification during installation. Refer to Specifications, *Hydraulic Hose and Fitting Torque Specifications*.

- 1 Remove the platform. Refer to Repair Procedure, *How to Remove the Platform*.
- 2 Tag and disconnect the electrical connector from the platform angle sensor.

- 3 Remove the platform angle sensor retaining fasteners. Remove the platform angle sensor from the platform rotator.

NOTICE Component damage hazard. The platform angle sensor is a very sensitive instrument. It can be damaged internally if is dropped or sustains any physical shock, even if the damage is not visible.

- 4 Tag, disconnect and plug the hydraulic hoses from the platform rotator manifold. Cap the fittings on the manifold.

WARNING Bodily injury hazard. Spraying hydraulic oil can penetrate and burn skin. Loosen hydraulic connections very slowly to allow the oil pressure to dissipate gradually. Do not allow oil to squirt or spray.

- 5 Tag, disconnect and plug the hydraulic hoses from the platform manifold. Cap the fittings on the manifold.

WARNING Bodily injury hazard. Spraying hydraulic oil can penetrate and burn skin. Loosen hydraulic connections very slowly to allow the oil pressure to dissipate gradually. Do not allow oil to squirt or spray.

- 6 Remove the power to platform electrical outlet box bracket mounting fasteners. Do not disconnect the wiring.

Platform Components

- 7 Remove the hose and cable guide retaining fasteners and remove the guide from the platform support.
- 8 Remove the weld cable from the platform (if equipped).

⚠ WARNING Electrocutation/burn hazard. Contact with electrically charged circuits could result in death or serious injury. Remove all rings, watches and other jewelry.

- 9 Support the platform mounting weldment, but do not apply any lifting pressure.
- 10 Remove the eight mounting bolts from the platform mounting weldment.
- 11 Remove the center bolt and slide the platform mounting weldment off of the platform rotator.

⚠ WARNING Crushing hazard. The platform mounting weldment may become unbalanced and fall if it is not properly supported.

- 12 Support the platform rotator with a suitable lifting device. Do not apply any lifting pressure.
- 13 Place a block under the platform leveling cylinder for support.
- 14 Remove the pin retaining fasteners from the platform leveling cylinder rod-end pivot pin. Do not remove the pin.
- 15 Remove the pin retaining fasteners from the jib boom to platform rotator pivot pin. Do not remove the pin.
- 16 Use a soft metal drift to remove both pins and remove the platform rotator from the machine.

⚠ WARNING Crushing hazard. The platform rotator could fall when removed from the machine if not properly supported.

How to Bleed the Platform Rotator

Note: Do not start the engine. Use auxiliary power for all machine functions in this procedure.

- 1 Rotate the platform full right, then full left until air is completely out of the rotator. Bleeding the valve is not necessary.

Platform Components

2-3

Platform Level Sensor

The platform level sensor is mounted to the side of the platform rotator. The platform level sensor is monitored by the control system to maintain a level platform through boom range of motion. If a platform level sensor is replaced, it must be calibrated prior to machine operation.

How to Calibrate the Platform Level Sensor

Note: Perform this procedure with the machine on a firm, level surface.

Note: Perform this procedure with the boom in the stowed position.

Note: Use the following chart to identify the description of each LCD screen control button used in this procedure.



Plus



Minus



Previous



Enter

- 1 Secure a digital level to one of the side railings of the platform.
- 2 Start the machine and level the platform to gravity. Turn the machine off.
- 3 Open the ground control box.

Before serial number 321:

- 4 Locate the 2 pin connector in the lower left hand area of the ground control box.
- 5 Remove the connector plug and insert a jumper wire between the two pins of the connector.

After serial number 320:

- 6 Locate the calibration toggle switch at the top of the ground control box. Activate calibration mode by moving the toggle switch in the left direction.
- 7 Temporarily install a control box door retaining fastener between the door and the box to prevent the control box door from moving the toggle switch while calibrating the machine.

All models:

- 8 Insert the key into the bypass/recovery key switch and turn it to the bypass position.

Note: The angle sensor calibration values will not be saved correctly unless the key switch is in the bypass position and the calibration toggle switch is activated.

- 9 Press and hold the **enter** button on the ground control panel while turning the key switch to ground controls. Hold the **enter** button for approximately 5 seconds.
- 10 Enter sensor calibration mode by pressing the buttons at the ground controls in the following sequence: **(plus)(enter)(enter)(plus)**.

Platform Components

- 11 Press the **enter** or **previous** button on the LCD screen until SET PLATFORM LEVEL SENSOR TO GRAVITY is displayed.
- 12 Press the **plus** button to select YES, then press the **enter** button to accept.
- 13 Press the **enter** or **previous** button on the LCD screen until EXIT is displayed.
- 14 Press the **plus** button to select YES, then press the **enter** button to accept.

Before serial number 321:

- 15 Remove the wire jumper from the 2 pin connector in the lower left hand area of the ground control box that was installed in step 5. Install the connector plug.

▲ DANGER

Tip-over hazard. Failure to remove the jumper wire will result in an unsafe configuration which will compromise machine stability. Operating the machine in this configuration will result in the machine tipping over, resulting in death or serious injury. The jumper wire must be removed before operating the machine.

- 16 Close the ground control box and install the door retaining fasteners.

After serial number 320:

- 17 Remove the fastener that was temporarily installed. Close the control box door and install the door retaining fasteners.

Note: When the control box door is closed, the calibration toggle switch is automatically activated to exit out of calibration mode.

2-4

Platform Overload System (if equipped)

Proper calibration of the platform overload system is essential to safe machine operation. Continued use of an improperly calibrated platform overload system could result in the system failing to sense an overloaded platform. The stability of the machine is compromised and it could tip over.

How to Calibrate the Platform Overload System (if equipped)

Note: Perform this procedure with the machine on a firm, level surface.

- 1 Level the platform.
- 2 Determine the maximum platform capacity. Refer to the machine serial plate.
- 3 Using a suitable lifting device, place an appropriate test weight equal to that of the maximum platform capacity at the center of the platform floor.

Platform Components

Determine the limit switch trigger point:

- 4 Gently move the platform up and down by hand, so it bounces approximately 1 to 2 inches / 2.5 to 5 cm. Allow the platform to settle.
- ⦿ Result: **The overload indicator light and the alarm is on.** Slowly tighten the load spring adjustment nut by turning it clockwise just until the overload indicator light and alarm turns off.

Note: The platform will need to be moved up and down and allowed to settle in between adjustments.

Note: There may be a 2 second delay before the overload indicator lights flash and the alarm sounds.

- ⦿ Result: **The overload indicator light and alarm is off.** Slowly loosen the load spring adjustment nut by turning it counterclockwise just until the overload indicator light and alarm turn on.

Note: There may be a 2 second delay before the overload indicator lights flash and the alarm sounds.

Note: The platform will need to be moved up and down and allowed to settle in between adjustments.

Confirm the setting:

- 5 Start the engine from the platform controls.
- 6 Lift the test weight off the platform floor using a suitable lifting device.
- 7 Place the test weight back onto the center of the platform floor using a suitable lifting device.

- ⦿ Result: The alarm should be off. The platform overload indicator light should be off at the platform controls and there should be no error message on the LCD display at the ground controls.

Note: There may be a 2 second delay before the overload indicator lights and alarm turn off.

- 8 Add an additional 15 lbs / 6.8 kg test weight to the original test weight to overload the platform.

- ⦿ Result: The alarm should be sounding. The platform overload indicator light should be flashing at the platform controls and platform overload should be displayed on the LCD screen at the ground controls.

Note: There may be a 2 second delay before the overload indicator lights flash and the alarm sounds.

Platform Components

- 9 Test all machine functions from the platform controls.
 - ⦿ Result: All platform control functions should not operate.
- 10 Turn the key switch to ground controls.
- 11 Test all machine functions from the ground controls.
 - ⦿ Result: All ground control functions should not operate.

Jib Boom Components

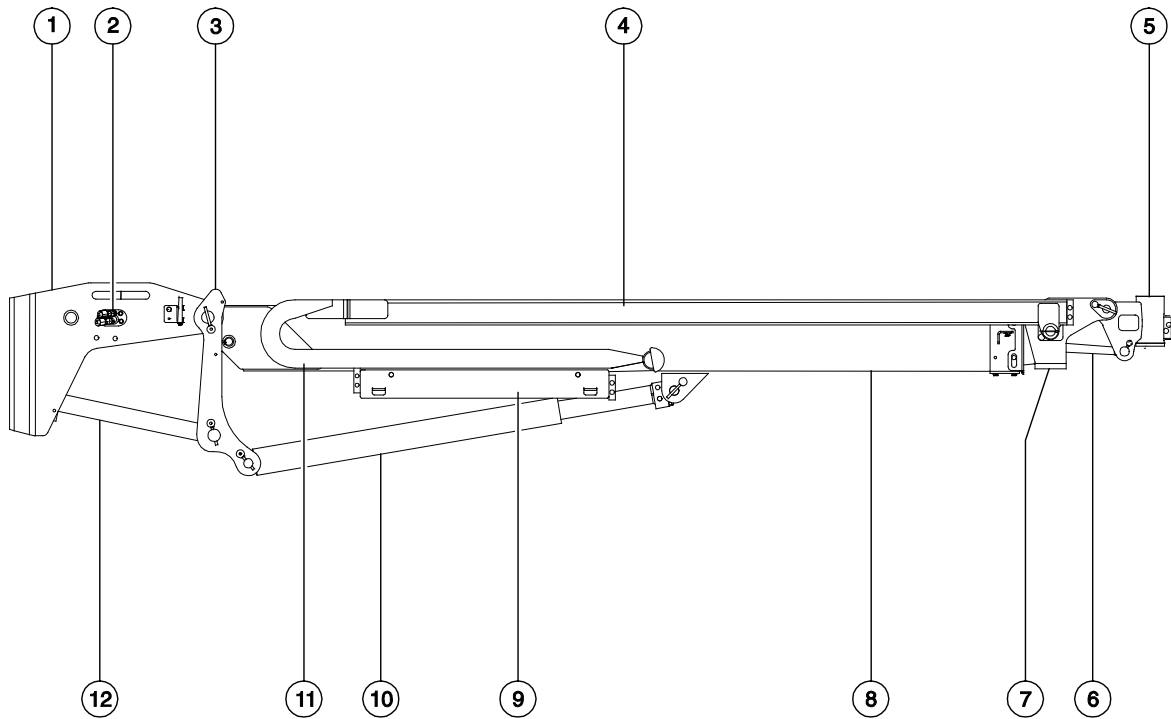

- 1 primary extension boom
- 2 jib boom manifold
- 3 bellcrank
- 4 cable track tube
- 5 platform rotator
- 6 platform leveling cylinder

- 7 jib boom
- 8 jib extension boom
- 9 hose and cable junction box
- 10 jib boom lift cylinder
- 11 jib boom cable track
- 12 jib boom leveling cylinder

Jib Boom Components

3-1 Jib Boom Cable Track

The jib boom cable track guides the cables and hoses running up the jib boom. It can be repaired link by link without removing the cables and hoses that run through it. Removing the entire jib boom cable track is only necessary when performing major repairs that involve removing the jib boom.

How to Remove the Jib Boom Cable Track

Note: When removing a hose assembly or fitting, the O-ring (if equipped) on the fitting and/or hose end must be replaced. All connections must be torqued to specification during installation. Refer to Specifications, *Hydraulic Hose and Fitting Torque Specifications*.

- 1 Raise the jib boom to a horizontal position. Turn the machine off.
- 2 Remove the cover from the hose and cable junction box under the jib boom cable track.
- 3 Tag and disconnect the electrical connectors inside the cable track junction box.

- 4 Tag, disconnect and plug the two hydraulic hoses from the jib boom manifold that lead to the platform manifold. Cap the fittings on the manifold.

▲ WARNING

Bodily injury hazard. Spraying hydraulic oil can penetrate and burn skin. Loosen hydraulic connections very slowly to allow the oil pressure to dissipate gradually. Do not allow oil to squirt or spray.

Note: The jib boom manifold is located at the platform end of the primary extension boom.

- 5 Pull the hoses out of the plastic hose guide located on the primary extension boom near the jib boom manifold.
- 6 Tag, disconnect and plug the jib boom lift cylinder hydraulic hoses. Cap the fittings on the cylinder.

▲ WARNING

Bodily injury hazard. Spraying hydraulic oil can penetrate and burn skin. Loosen hydraulic connections very slowly to allow the oil pressure to dissipate gradually. Do not allow oil to squirt or spray.

- 7 Remove the hose and cable clamp retaining fasteners from the jib boom cable track junction box. Remove the clamps.
- 8 Pull the jib boom lift cylinder hydraulic hoses out of the jib boom cable track junction box.

Jib Boom Components

- 9 Remove the hose and cable clamp retaining fasteners at the platform end of the jib boom cable track tube. Remove the clamps.
- 10 Tag and disconnect the electrical connectors from the platform manifold.
- 11 Tag and disconnect the electrical connectors from the platform box.
- 12 Tag and disconnect the electrical connector from the foot switch.
- 13 Tag and disconnect the electrical connector from the platform angle sensor.
- 14 Tag, disconnect and plug the hydraulic hoses from the "P" and "T" ports on the platform manifold.
- 15 Pull the two hydraulic hoses just removed and all of the cables through the hose and cable guide at the platform support.

NOTICE Component damage hazard. Cables and hoses can be damaged if they are kinked or pinched.

- 16 Remove the cotter pin from the upper cable track tube at the platform end of the jib boom. Do not discard the washer.

Note: Always replace the cotter pin with a new one.

- 17 Remove the fasteners from the cable track tube guide at the platform end of the jib boom. Remove the cable track tube guide from the jib boom.
- 18 Place blocks between the upper and lower cable tracks and secure the upper and lower tracks together.

WARNING Crushing hazard. If the upper and lower cable tracks are not properly secured together, the cable track could become unbalanced and fall when removed from the machine.

- 19 Attach a lifting strap from an overhead crane to the cable track.
- 20 Remove the mounting fasteners that attach the lower cable track to the jib boom.
- 21 Carefully remove the cable track from the machine and lay it on a structure capable of supporting it.

WARNING Crushing hazard. The cable track could become unbalanced and fall if not properly attached to the overhead crane.

NOTICE Component damage hazard. Cables and hoses can be damaged if they are kinked or pinched.

Jib Boom Components

How to Repair the Cable Track

NOTICE Component damage hazard. The boom cable track can be damaged if it is twisted.

Note: A cable track repair kit is available through the Genie Service Parts Department.

- 1 Visually inspect the cable track and determine which 4-link section needs to be replaced.
- 2 Carefully remove the snap rings and pins from each end of the damaged section of cable track.
- 3 Remove the retaining fasteners from the upper black rollers from the 4-link section of cable track to be replaced. Remove the rollers.
- 4 Lift up the hoses and cables and carefully remove the damaged 4-link section of cable track.

NOTICE Component damage hazard. Cables and hoses can be damaged if they are kinked or pinched.

- 5 Remove the upper rollers from the replacement section of cable track.

- 6 Lift up the hoses and cables and carefully insert the new 4-link section of cable track.

NOTICE Component damage hazard. Cables and hoses can be damaged if they are kinked or pinched.

- 7 Connect the ends of the replacement cable track section to the existing cable track using the pins and snap rings.
- 8 Install the rollers onto the new section of cable track.
- 9 Operate the jib boom extend/retract function through a full cycle to ensure smooth operation of the new section of cable track.

Jib Boom Components

3-2 Jib Boom

How to Remove the Jib Boom

▲WARNING Bodily injury hazard. This procedure requires specific repair skills, lifting equipment and a suitable workshop. Attempting this procedure without these skills and tools could result in death or serious injury and significant component damage. Dealer service is strongly recommended.

Note: Perform this procedure with the boom in the stowed position.

Note: When removing a hose assembly or fitting, the O-ring (if equipped) on the fitting and/or hose end must be replaced. All connections must be torqued to specification during installation. Refer to Specifications, *Hydraulic Hose and Fitting Torque Specifications*.

- 1 Remove the platform mounting weldment and the platform rotator. Refer to Repair Procedure, *How to Remove the Platform Rotator*.

- 2 Tag, disconnect and plug the two hydraulic hoses from the jib boom manifold that lead to the platform manifold. Cap the fittings on the manifold.

▲WARNING Bodily injury hazard. Spraying hydraulic oil can penetrate and burn skin. Loosen hydraulic connections very slowly to allow the oil pressure to dissipate gradually. Do not allow oil to squirt or spray.

- 3 Tag, disconnect and plug the jib boom lift cylinder hydraulic hoses from the jib boom manifold. Cap the fittings on the manifold.

▲WARNING Bodily injury hazard. Spraying hydraulic oil can penetrate and burn skin. Loosen hydraulic connections very slowly to allow the oil pressure to dissipate gradually. Do not allow oil to squirt or spray.

- 4 Remove the cotter pin from the upper cable track tube at the platform end of the jib boom.

Note: Always replace the cotter pin with a new one.

- 5 Remove the cable track guide fasteners from the cable track guide at the platform end of the jib boom and remove the cable track guide from the jib boom.

Jib Boom Components

- 6 Place blocks between the upper and lower cable tracks and secure the upper and lower tracks together.

▲ WARNING Crushing hazard. If the upper and lower cable tracks are not properly secured together, the cable track could become unbalanced and fall when removed from the machine.

- 7 Attach a lifting strap from an overhead crane to the cable track.
- 8 Remove the mounting fasteners that attach the lower cable track to the jib boom.
- 9 Remove the cable track from the machine and lay to the side.

▲ WARNING Crushing hazard. The cable track could become unbalanced and fall if not properly attached to the overhead crane.

NOTICE Component damage hazard. Cables and hoses can be damaged if they are kinked or pinched.

- 10 Disconnect the electrical connector from the jib boom angle sensor located at the jib boom pivot pin on the engine side of the machine.
- 11 Remove the cover retaining fasteners from the jib boom angle sensor. Remove the cover.

- 12 Remove the jib boom angle sensor mounting bracket fasteners from the side of the primary extension boom.

- 13 Carefully remove the bracket and sensor assembly. Note the location of the springs. Do not lose the springs.

Note: There is one spring inside the jib boom pivot pin and one inside the angle sensor.

Note: When the jib boom is installed, the jib boom angle sensor will need to be calibrated. Refer to repair procedure, *Jib Boom Bellcrank Angle Sensor* for the calibration procedure.

- 14 Attach a lifting strap from an overhead crane to the platform end of the jib boom.
- 15 Support the barrel end of the jib boom lift cylinder with another suitable lifting device.
- 16 Remove the pin retaining fasteners from the jib boom lift cylinder barrel-end pivot pin.
- 17 Use a soft metal drift to remove the jib boom lift cylinder barrel-end pivot pin.

▲ WARNING Crushing hazard. The jib boom could fall when the barrel-end pivot pin is removed if not properly supported by the overhead crane.

▲ WARNING Crushing hazard. The jib boom lift cylinder may become unbalanced and fall when it is removed from the machine if it is not properly supported by the overhead crane.

- 18 Secure the jib boom lift cylinder to the jib boom with a strap or other suitable device.
- 19 Raise the jib boom to a horizontal position using the overhead crane.
- 20 Attach a second lifting strap from the overhead crane to the pivot end of the jib boom.
- 21 Remove the pin retaining fastener from the jib boom pivot pin. Do not remove the pin.

Jib Boom Components

- 22 Place a block under the jib boom level cylinder for support. Protect the cylinder rod from damage.
- 23 Use a soft metal drift to tap the pin halfway out in one direction and lower one side of the jib boom bellcrank. Tap the pin in the other direction and lower the other side of the jib boom bellcrank.
- 24 Use a soft metal drift to remove the jib boom pivot pin. Remove the jib boom from the machine and place it on a structure capable of supporting it.

⚠ WARNING Crushing hazard. The jib boom may become unbalanced and fall when it is removed from the machine if it is not properly supported by the overhead crane.

3-3

Jib Boom Lift Cylinder

How to Remove the Jib Boom Lift Cylinder

Note: Perform this procedure with the boom in the stowed position.

Note: When removing a hose assembly or fitting, the O-ring (if equipped) on the fitting and/or hose end must be replaced. All connections must be torqued to specification during installation. Refer to Specifications, *Hydraulic Hose and Fitting Torque Specifications*.

- 1 Raise the jib boom slightly and place blocks under the platform mounting weldment. Lower the jib boom until the platform is resting on the blocks just enough to support the platform.

Note: Do not rest the entire weight of the boom on the blocks.

- 2 Tag, disconnect and plug the jib boom lift cylinder hydraulic hoses. Cap the fittings on the cylinder.

⚠ WARNING Bodily injury hazard. Spraying hydraulic oil can penetrate and burn skin. Loosen hydraulic connections very slowly to allow the oil pressure to dissipate gradually. Do not allow oil to squirt or spray.

- 3 Support the rod end of the jib boom lift cylinder with a suitable lifting device.

Jib Boom Components

- 4 Remove the pin retaining fasteners from the jib boom lift cylinder rod-end pivot pin. Use a soft metal drift to remove the pin and let the cylinder hang down.
- 5 Attach a lifting strap from an overhead crane to the barrel end of jib boom lift cylinder.
- 6 Remove the pin retaining fasteners from the jib boom lift cylinder barrel-end pivot pin. Use a soft metal drift to remove the pin.
- 7 Remove the jib boom lift cylinder from the machine.

⚠ WARNING

Crushing hazard. The jib boom lift cylinder may become unbalanced and fall when it is removed from the machine if it is not properly supported by the overhead crane.

3-4

Jib Boom Level Cylinder

How to Remove the Jib Boom Level Cylinder

Note: Perform this procedure with the boom in the stowed position.

Note: When removing a hose assembly or fitting, the O-ring (if equipped) on the fitting and/or hose end must be replaced. All connections must be torqued to specification during installation. Refer to Specifications, *Hydraulic Hose and Fitting Torque Specifications*.

- 1 Extend the primary boom until the jib boom level cylinder barrel-end pivot pin is accessible.
- 2 Raise the jib boom above horizontal.
- 3 Attach an overhead crane to the jib boom assembly for support.
- 4 Place a block under the jib boom level cylinder for support. Protect the cylinder rod from damage.
- 5 Remove the pin retaining fasteners from the jib boom level cylinder rod-end pivot pin. Use a soft metal drift to remove the pin.

⚠ WARNING

Crushing hazard. The jib boom could fall if not properly supported when the jib boom level cylinder rod-end pivot pin is removed.

Jib Boom Components

- 6 Remove the external snap rings from the jib boom level cylinder barrel-end pivot pin. Use a soft metal drift to remove the pin.
- 7 Tag, disconnect and plug the jib boom level cylinder hydraulic hoses from the jib boom manifold. Cap the fittings on the manifold.

⚠ WARNING Bodily injury hazard. Spraying hydraulic oil can penetrate and burn skin. Loosen hydraulic connections very slowly to allow the oil pressure to dissipate gradually. Do not allow oil to squirt or spray.

- 8 Attach an overhead crane or other suitable device to the jib boom level cylinder for support.
- 9 Carefully remove the jib boom level cylinder from the machine.

⚠ WARNING Crushing hazard. The jib boom level cylinder could become unbalanced and fall when removed from the machine if not properly supported.

3-5 Jib Boom Extension Cylinder

How to Remove the Jib Boom Extension Cylinder

⚠ WARNING Bodily injury hazard. This procedure requires specific repair skills, lifting equipment and a suitable workshop. Attempting this procedure without these skills and tools could result in death or serious injury and significant component damage. Dealer service is strongly recommended.

Note: Perform this procedure with the boom in the stowed position.

Note: When removing a hose assembly or fitting, the O-ring (if equipped) on the fitting and/or hose end must be replaced. All connections must be torqued to specification during installation. Refer to Specifications, *Hydraulic Hose and Fitting Torque Specifications*.

- 1 Remove the jib boom lift cylinder. Refer to Repair Procedure, *How to Remove the Jib Boom Lift Cylinder*.
- 2 Attach a lifting strap from an overhead crane to the platform end of the jib boom for support. Raise the jib boom to a horizontal position using the overhead crane.

Jib Boom Components

- 3 Extend the jib boom until the jib boom extension cylinder rod-end pivot pin is accessible.
- 4 Tag, disconnect and plug the two hydraulic hoses from the jib boom manifold that lead to the platform manifold. Cap the fittings on the manifold.

⚠ WARNING Bodily injury hazard. Spraying hydraulic oil can penetrate and burn skin. Loosen hydraulic connections very slowly to allow the oil pressure to dissipate gradually. Do not allow oil to squirt or spray.

- 5 Tag, disconnect and plug the jib boom lift cylinder and jib boom extension cylinder hydraulic hoses from the jib boom manifold. Cap the fittings on the manifold.

⚠ WARNING Bodily injury hazard. Spraying hydraulic oil can penetrate and burn skin. Loosen hydraulic connections very slowly to allow the oil pressure to dissipate gradually. Do not allow oil to squirt or spray.

- 6 Remove the cover from the lower jib boom cable track.
- 7 Tag and disconnect the electrical connectors inside the lower cable track.
- 8 Remove the hose and cable clamp retaining fasteners from lower cable track at the pivot end of the jib boom. Remove the clamps.

- 9 Pull the electrical cables out of the lower cable track that lead to the primary boom.
- 10 Attach a lifting strap from a second overhead crane to the pivot end of the jib boom for support. Do not apply any lifting pressure.
- 11 Place a block under the jib boom level cylinder for support. Protect the cylinder rod from damage.
- 12 Remove the pin retaining fastener from the jib boom pivot pin. Do not remove the pin.
- 13 Use a soft metal drift to tap the pin halfway out in one direction and lower one side of the jib boom bellcrank. Tap the pin in the other direction and lower the other side of the jib boom bellcrank.
- 14 Use a soft metal drift to remove the jib boom pivot pin. Remove the jib boom from the machine and place it on a structure capable of supporting it.

⚠ WARNING Crushing hazard. The jib boom may become unbalanced and fall when it is removed from the machine if it is not properly supported by the overhead crane.

- 15 Remove the pin retaining fasteners from the jib boom extension cylinder rod-end pivot pin. Use a soft metal drift to remove the pin.

Jib Boom Components

- 16 Attach a lifting strap from an overhead crane to the barrel end of the jib boom extension cylinder.
- 17 Remove the pin retaining fasteners from the jib boom extension cylinder barrel-end pivot pin. Use a soft metal drift to remove the pin.
- 18 Carefully slide the jib boom extension cylinder out of the jib boom and place it on a structure capable of supporting it.

⚠ WARNING

Crushing hazard. The jib boom extension cylinder could become unbalanced and fall when removed from the jib boom if not properly supported.

Note: During removal, the overhead crane strap will need to be adjusted for proper balancing.

3-6

Jib Boom Bellcrank Angle Sensor

The jib boom bellcrank angle sensor is monitored by the control system to keep the jib boom bellcrank vertical and to help maintain a level platform through boom range of motion. If a jib boom bellcrank angle sensor is replaced, it must be calibrated prior to machine operation. The jib boom bellcrank angle sensor is mounted to the bellcrank pivot pin on the engine side of the machine.

How to Replace the Jib Boom Bellcrank Angle Sensor

Note: Perform this procedure with the machine on a firm, level surface with the boom in the stowed position.

- 1 Locate the jib boom bellcrank angle sensor where the jib boom bellcrank connects to the primary boom.
- 2 Disconnect the electrical connector from the sensor. Remove any tie wraps securing the wiring.
- 3 Remove the retaining fasteners from the angle sensor guard. Remove the guard from the machine.

Jib Boom Components

- 4 Remove the angle sensor cover retaining fastener. Remove the cover.
- 5 Remove the angle sensor mounting bracket retaining fasteners.
- 6 Remove the angle sensor and bracket assembly. Do not lose the two springs or the hex-shaped key.
- 7 Remove the sensor retaining fasteners from the mounting bracket. Remove the angle sensor.

Note: Note the sensor orientation on the bracket during removal so the new sensor will be installed in the same position.

- 8 Install the new angle sensor onto the mounting bracket.
- 9 Install one spring, removed in step 6, into the hex-shaped hole in the angle sensor. Install the other spring into the hex-shaped hole in the center of the boom pivot pin.
- 10 Insert the hex-shaped key into the angle sensor.

- 11 Align the side of the sensor with flat area of the boom pivot pin as shown below.

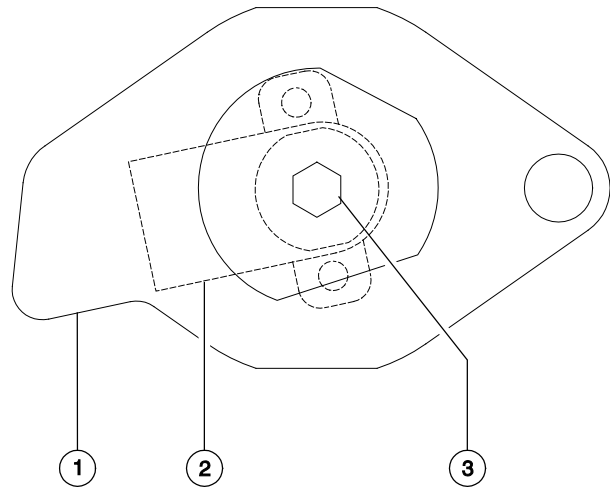

- 1 flat area
- 2 angle sensor
- 3 hex-shaped hole

- 12 Insert the hex-shaped key into the bellcrank pivot pin allowing free clockwise rotation of the angle sensor mounting bracket.

Note: Be sure the hex-shaped key remains engaged in the sensor.

Jib Boom Components

- 13 Rotate the angle sensor mounting bracket, while holding the key in the sensor, clockwise until the mounting bracket fits into the machined pocket.
- 14 Install the angle sensor bracket retaining fasteners.
- 15 Install the angle sensor cover and install the cover retaining fasteners.
- 16 Connect the electrical connector to the new sensor.
- 17 Install the angle sensor guard over the angle sensor.
- 18 Calibrate the jib boom bellcrank angle sensor. Refer to Repair Procedure, *How to Calibrate the Jib Boom Bellcrank Angle Sensor*.

How to Calibrate the Jib Boom Bellcrank Angle Sensor

Note: If the primary boom or secondary boom angle sensors have been removed or replaced, or the turntable level sensor has been replaced, they must be calibrated before the jib boom bellcrank angle sensor. Refer to Repair Procedures, *How to Calibrate the Primary Boom Angle Sensor* or *How to Calibrate the Secondary Boom Angle Sensor* or *How to Calibrate the Turntable Level Sensor*.

Note: Perform this procedure with the machine on a firm, level surface and in the stowed position with the axles extended.

Note: A digital level will be required to perform this procedure.

Note: A kit is available through Genie Product Support (Genie part number 58351). This kit includes a digital level with a magnetic base and cable harnesses.

Jib Boom Components

Note: Use the following chart to identify the description of each LCD screen control button used in this procedure.



Plus



Minus



Previous



Enter

Digital levels with alternate zero function:

- 1 Prepare the digital level by placing it vertically on a known surface that is perpendicular to gravity. Zero out the level with the alternate zero function.

Note: When the level is calibrated correctly, it should read 0° on a vertical surface.

Digital levels without alternate zero function:

Note: If your digital level does not have an alternate zero function, it will read 90° on a vertical surface. During calibration, the measured value will need to be subtracted from 90 degrees to get the correct number to enter into the system.

- 2 Raise the jib boom to a slightly less than horizontal position.
- 3 Push in the ground controls red Emergency Stop button to the off position. Do not turn the key switch to the off position.
- 4 Open the ground control box.

Before serial number 321:

- 5 Locate the 2 pin connector in the lower left hand area of the ground control box.
- 6 Remove the connector plug and insert a jumper wire between the two pins of the connector.

After serial number 320:

- 7 Locate the calibration toggle switch at the top of the ground control box. Activate calibration mode by moving the toggle switch in the left direction.
- 8 Temporarily install a control box door retaining fastener between the door and the box to prevent the control box door from moving the toggle switch while calibrating the machine.

All models:

- 9 Remove the key from the main key switch. Insert the key into the bypass/recovery key switch and turn it to the bypass position.

Note: The angle sensor calibration values will not be saved correctly unless the key switch is in the bypass position.

- 10 Press and hold the **enter** button on the ground control panel while pulling out the ground controls red Emergency Stop button to the on position. Hold the **enter** button for approximately 5 seconds and then release it.

Jib Boom Components

- 11 Enter sensor calibration mode by pressing the buttons at the ground controls in the following sequence: **(plus)(enter)(enter)(plus)**.
- 12 Press the **enter** or **previous** button on the LCD screen until DELETE JIB LEVEL ANGLE SENSOR CALIBRATION is displayed.
- 13 Press the **plus** button to select YES, then press the **enter** button to accept.
- 14 At the jib level calibration deg 60.0deg screen, start the engine.

Note: If the system exits out of calibration mode when the engine is started, repeat step 7 and continue to step 12.

- 15 Press and hold a function enable/speed select button and the platform level up button. Fully extend the jib boom level cylinder.

Note: When in service/bypass mode, the platform level buttons are used to adjust the jib boom level cylinder.

Note: With the jib boom level cylinder is fully extended, the jib boom bellcrank angle should be at approximately 60 ± 2 degrees.

- 16 Attach the digital level to the surface of the jib boom bellcrank as shown.

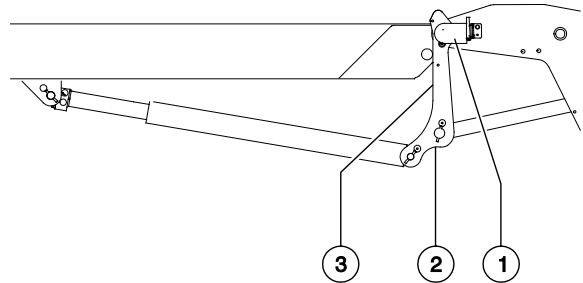

- 1 jib boom angle sensor
- 2 jib boom bellcrank
- 3 place level on this surface

- 17 At the ground controls, press the **plus** button or **minus** button to adjust the display to the exact value shown on the digital level and press the **enter** button.

Note: If the measured angle already matches the angle shown on the display at the ground controls, press the **plus** button or **minus** button to change the angle and then change back to the measured value. The system must detect a change in displayed value to record the calibrated value.

Jib Boom Components

- 18 Press and hold a function enable/speed select button and the platform level down button until the digital level displays approximately 34 ± 2 degrees.
- 19 At the ground controls, press the **plus** button or **minus** button to adjust the display to the exact value shown on the digital level and press the **enter** button.

Note: If the measured angle already matches the angle shown on the display at the ground controls, press the **plus** button or **minus** button to change the angle and then change back to the measured value. The system must detect a change in displayed value to record the calibrated value.

- 20 Press and hold a function enable/speed select button and the platform level down button until the digital level displays approximately 8 ± 2 degrees.
- 21 At the ground controls, press the **plus** button or **minus** button to adjust the display to the exact value shown on the digital level and press the **enter** button.

Note: If the measured angle already matches the angle shown on the display at the ground controls, press the **plus** button or **minus** button to change the angle and then change back to the measured value. The system must detect a change in displayed value to record the calibrated value.

- 22 Press and hold a function enable/speed select button and raise the jib boom above horizontal to provide additional ground clearance for the remaining calibration points.
- 23 Press and hold a function enable/speed select button and the platform level down button until the digital level displays approximately 18 ± 2 degrees.

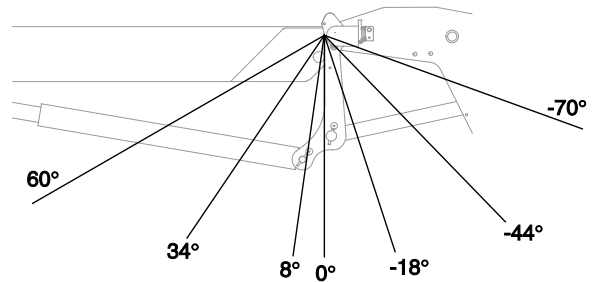

Calibration angles

- 24 At the ground controls, press the **plus** button or **minus** button to adjust the display to the exact value shown on the digital level and press the **enter** button.

Note: Be sure the number entered at the ground controls is a negative number.

Note: If the measured angle already matches the angle shown on the display at the ground controls, press the **plus** button or **minus** button to change the angle and then change back to the measured value. The system must detect a change in displayed value to record the calibrated value.

Jib Boom Components

25 Press and hold a function enable/speed select button and the platform level down button until the digital level displays approximately 44 ± 2 degrees.

26 At the ground controls, press the **plus** button or **minus** button to adjust the display to the exact value shown on the digital level and press the **enter** button.

Note: Be sure the number entered at the ground controls is a negative number.

Note: If the measured angle already matches the angle shown on the display at the ground controls, press the **plus** button or **minus** button to change the angle and then change back to the measured value. The system must detect a change in displayed value to record the calibrated value.

27 Press and hold a function enable/speed select button and the platform level down button until the digital level displays approximately 70 ± 2 degrees. The jib boom level cylinder should be fully retracted at this point.

28 At the ground controls, press the **plus** button or **minus** button to adjust the display to the exact value shown on the digital level and press the **enter** button.

Note: Be sure the number entered at the ground controls is a negative number.

Note: If the measured angle already matches the angle shown on the display at the ground controls, press the **plus** button or **minus** button to change the angle and then change back to the measured value. The system must detect a change in displayed value to record the calibrated value.

Note: With the jib boom level cylinder fully retracted, the jib boom bellcrank angle should be at approximately 70 degrees.

29 Press and hold the engine start button for approximately 5 seconds to shut off the engine and to save the calibration settings.

Note: Do not turn the engine off with the key switch or red Emergency Stop button or all calibration points or values will not be saved.

30 Press the **enter** or **previous** button on the LCD screen until EXIT is displayed. Press the **plus** button to select YES, then press the **enter** button to accept.

31 Turn the key back to the run position and remove the key from the bypass/recovery key switch. Insert the key into the main key switch and turn it to ground controls.

Note: Be sure that the bypass/recovery key switch is in the run position before attempting to operate the machine.

32 Wait approximately 20 seconds and turn the machine off by pressing the red Emergency Stop button in.

Jib Boom Components

Before serial number 321:

- 33 Remove the wire jumper from the 2 pin connector in the lower left hand area of the ground control box that was installed in step 6. Install the connector plug.

⚠ DANGER

Tip-over hazard. Failure to remove the jumper wire will result in an unsafe configuration which will compromise machine stability. Operating the machine in this configuration will result in the machine tipping over, resulting in death or serious injury. The jumper wire must be removed before operating the machine.

- 34 Close the ground control box and install the door retaining fasteners.

After serial number 320:

- 35 Remove the fastener that was temporarily installed. Close the control box door and install the door retaining fasteners.

Note: When the control box door is closed, the calibration toggle switch is automatically activated to exit out of calibration mode.

All models:

- 36 Pull out the red Emergency Stop button. Start the engine and lower the boom to the stowed position. Be sure there are no calibration faults shown on the display.

Boom Components

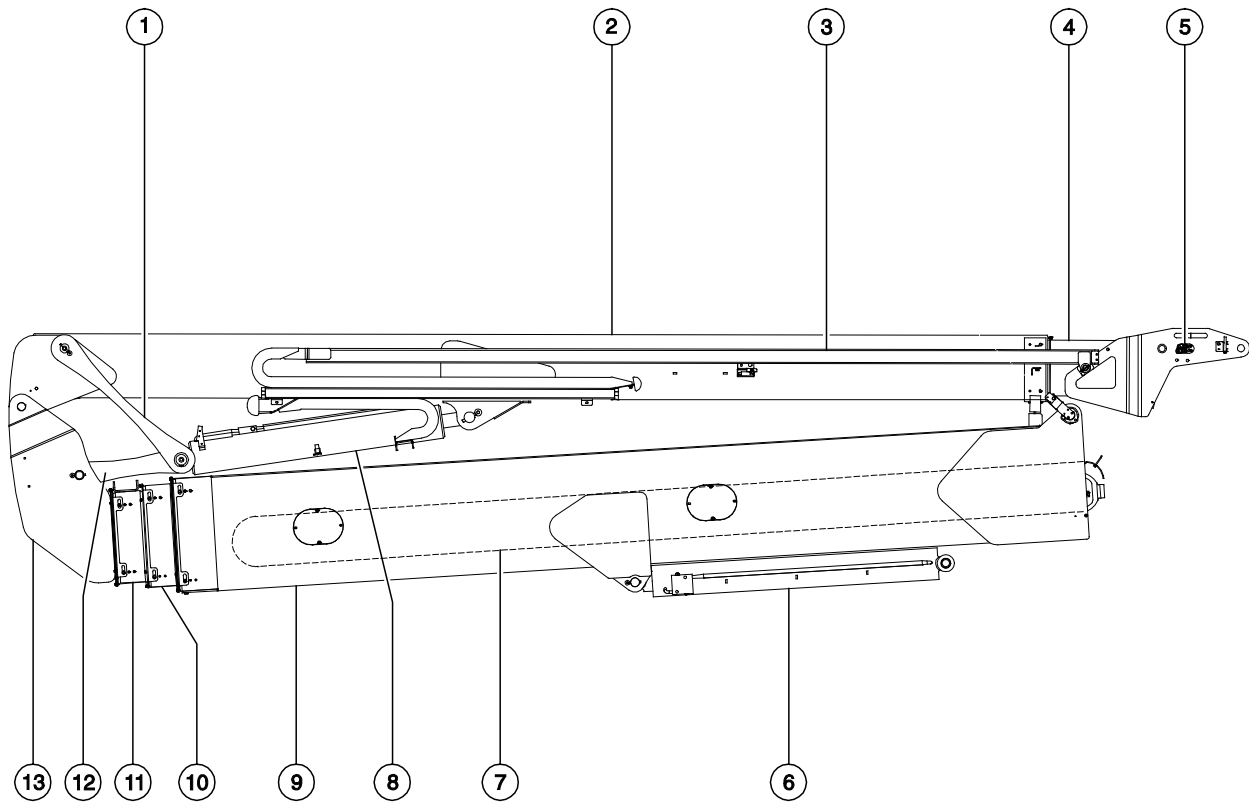

- | | |
|---|--|
| <ul style="list-style-type: none"> 1 upper primary boom lift cylinder linkage arm 2 primary boom 3 cable track 4 primary extension boom 5 jib boom manifold 6 secondary boom lift cylinder 7 secondary boom cable track (inside of secondary boom) | <ul style="list-style-type: none"> 8 primary boom lift cylinder 9 number 1 secondary boom tube 10 number 2 secondary boom tube 11 number 3 secondary boom tube 12 lower primary boom lift cylinder linkage arm 13 number 4 secondary boom tube |
|---|--|

Boom Components

4-1 Primary Boom Cable Track

The primary boom cable track guides the cables and hoses running up the boom. It can be repaired link by link without removing the cables and hoses that run through it. Removing the entire primary boom cable track is only necessary when performing major repairs that involve removing the primary boom.

How to Remove the Primary Boom Cable Track

Note: When removing a hose assembly or fitting, the O-ring (if equipped) on the fitting and/or hose end must be replaced. All connections must be torqued to specification during installation. Refer to Specifications, *Hydraulic Hose and Fitting Torque Specifications*.

Note: Perform this procedure with the machine on a firm, level surface.

Note: Perform this procedure with the boom in the stowed position.

- 1 Remove the cover from the lower jib boom cable track.
- 2 Tag and disconnect the electrical connectors inside the lower cable track.
- 3 Remove the hose and cable clamp retaining fasteners from lower cable track at the pivot end of the jib boom. Remove the clamps.

- 4 Pull the electrical cables out of the lower cable track that lead to the primary boom.

NOTICE Component damage hazard. Cables can be damaged if they are kinked or pinched.

- 5 Tag and disconnect the electrical connectors from the jib boom manifold located at the platform end of the primary extension boom.
- 6 Tag, disconnect and plug the two hydraulic hoses from the jib boom manifold that lead to the platform manifold. Cap the fittings on the manifold.

WARNING Bodily injury hazard. Spraying hydraulic oil can penetrate and burn skin. Loosen hydraulic connections very slowly to allow the oil pressure to dissipate gradually. Do not allow oil to squirt or spray.

- 7 Remove the retaining fasteners from the hose and cable guide at the platform end of the primary boom. Remove the hose and cable guide.
- 8 Tag and disconnect the electrical connector from the limit switch on the side of the primary boom. Do not remove the limit switch.
- 9 Remove the cotter pin from the upper cable track tube at the platform end of the primary extension boom.

Note: Always replace the cotter pin with a new one.

Boom Components

- 10 Remove the retaining fasteners from the cable track guide at the platform end of the boom. Remove the cable track guide from the machine.
- 11 Place blocks between the upper and lower cable tracks and secure the upper and lower tracks together.
- 15 Locate the two hydraulic hoses inside the end of the secondary boom that lead to the primary boom cable track.
- 16 Tag, disconnect and plug the hydraulic hoses from the unions. Cap the fittings on the unions.

⚠ WARNING Crushing hazard. If the upper and lower cable tracks are not properly secured together, the cable track could become unbalanced and fall when removed from the machine.

- 12 Remove the hose and cable clamps from the primary boom lift cylinder.
- 13 At the counterweight end of the secondary boom, support and secure the secondary boom lower end cover to a suitable lifting device.
- 14 Remove the cover retaining fasteners and remove the cover from the end of the secondary boom.

⚠ WARNING Crushing hazard. The secondary boom lower end cover could become unbalanced and fall when removed from the secondary boom if not properly supported and secured to the lifting device.

⚠ WARNING Bodily injury hazard. Spraying hydraulic oil can penetrate and burn skin. Loosen hydraulic connections very slowly to allow the oil pressure to dissipate gradually. Do not allow oil to squirt or spray.

- 17 Disconnect the electrical connectors for the electrical cables that lead to the cable track at the end of the secondary boom.
- 18 Pull all hydraulic hoses and electrical cables that lead to the cable track out of the secondary boom riser.

NOTICE Component damage hazard. Cables and hoses can be damaged if they are kinked or pinched.

- 19 Attach a lifting strap to each end of the cable track from an overhead crane for support. Do not apply any lifting pressure.

Boom Components

- 20 Remove the mounting fasteners that attach the lower cable track to the primary boom lift cylinder.
- 21 Remove the mounting fasteners that attach the cable track to the primary boom.
- 22 Carefully remove the cable track from the machine and lay it on a structure capable of supporting it.

⚠ WARNING Crushing hazard. The primary boom cable track could become unbalanced and fall when removed from the primary boom if not properly supported by the overhead crane.

NOTICE Component damage hazard. The boom cable track can be damaged if it is twisted.

NOTICE Component damage hazard. Cables and hoses can be damaged if they are kinked or pinched.

How to Repair the Primary Boom Cable Track

NOTICE Component damage hazard. The boom cable track can be damaged if it is twisted.

Note: A cable track repair kit is available through the Genie Service Parts Department.

- 1 Visually inspect the cable track and determine which 4-link section needs to be replaced.
- 2 Support the cable track assembly above the section to be replaced.
- 3 Carefully remove the snap rings and pins from each end of the damaged section of cable track.
- 4 Remove the retaining fasteners from the upper black rollers from the 4-link section of cable track to be replaced. Remove the rollers.
- 5 Lift up the hoses and cables and carefully remove the damaged 4-link section of cable track.

NOTICE Component damage hazard. Cables and hoses can be damaged if they are kinked or pinched.

Boom Components

- 6 Remove the upper rollers from the replacement section of cable track.
- 7 Lift up the hoses and cables and carefully insert the new 4-link section of cable track.

NOTICE Component damage hazard. Cables and hoses can be damaged if they are kinked or pinched.

- 8 Connect the ends of the replacement cable track section to the existing cable track using the pins and snap rings.
- 9 Install the rollers onto the new section of cable track.
- 10 Operate the primary boom extend/retract function through a full cycle to ensure smooth operation of the new section of cable track.

4-2

Secondary Boom Cable Track

The secondary boom cable track guides the cables and hoses running up through the inside of the secondary boom. It can be repaired link by link without removing the cables and hoses that run through it. Removal of the secondary boom cable track is required to repair it.

How to Remove the Secondary Boom Cable Track

Note: When removing a hose assembly or fitting, the O-ring (if equipped) on the fitting and/or hose end must be replaced. All connections must be torqued to specification during installation. Refer to Specifications, *Hydraulic Hose and Fitting Torque Specifications*.

- 1 Working at the counterweight end of the secondary boom, support and secure the secondary boom end cover to a suitable lifting device.
- 2 Remove the cover retaining fasteners and remove the cover from the secondary boom.

⚠ WARNING Crushing hazard. The secondary boom end cover could become unbalanced and fall when removed from the secondary boom if not properly supported and secured to the lifting device.

- 3 Working at the platform end of the secondary boom, support and secure the secondary boom end cover to a suitable lifting device.

Boom Components

- 4 Remove the cover retaining fasteners and remove the cover from the secondary boom.

WARNING Crushing hazard. The secondary boom end cover could become unbalanced and fall when removed from the secondary boom if not properly supported and secured to the lifting device.

- 5 Working at the platform end of the secondary boom, remove the hose and cable U-bolt fasteners near the upper cable track tube.
- 6 Working at the platform end of the secondary boom, remove the upper cable track tube retaining fasteners. Remove the curved hose guide.
- 7 Working at the platform end of the secondary boom, remove the lower cable track retaining fasteners.
- 8 Working at the counterweight end of the secondary boom, remove the lower cable track retaining fasteners.
- 9 Tag, disconnect and plug the hydraulic hoses from the following ports of the function manifold: PE, PR, P2, T1, PU and PD. Cap the fittings on the manifold.

WARNING Bodily injury hazard. Spraying hydraulic oil can penetrate and burn skin. Loosen hydraulic connections very slowly to allow the oil pressure to dissipate gradually. Do not allow oil to squirt or spray.

- 10 Pull the hydraulic hoses just removed through the turntable bulkhead.

NOTICE Component damage hazard. Hoses can be damaged if they are kinked or pinched.

- 11 Working at the counterweight end of the secondary boom, tag, disconnect and plug the hydraulic hoses from the unions that lead to the cable track.
- 12 Working at the counterweight end of the secondary boom, tag and disconnect the electrical connectors to all of the cables that lead to the secondary boom cable track.
- 13 Tag, disconnect and plug the primary boom lift cylinder hydraulic hoses. Cap the fittings on the cylinder.
- 14 Tag, disconnect and plug the primary boom extension cylinder hydraulic hoses at the unions located above the primary boom lift cylinder. Cap the fittings on the unions.
- 15 Pull the hydraulic hoses for the primary boom lift cylinder and extension cylinder out through the hole in the number 4 secondary boom tube.

NOTICE Component damage hazard. Hoses can be damaged if they are kinked or pinched.

- 16 Working at the platform end of the secondary boom, place blocks between the upper and lower cable tracks for support.

Boom Components

- 17 Working at the counterweight end of the secondary boom, attach a lifting strap from an overhead crane to the secondary boom cable track.
- 18 Carefully pull the secondary boom cable track out of the counterweight end of the boom.
- 19 Remove the secondary boom cable track from the machine and place it on a structure capable of supporting it.

WARNING Crushing hazard. The secondary boom cable track could become unbalanced and fall if not properly supported when removed from the machine.

NOTICE Component damage hazard. Cables and hoses can be damaged if they are kinked or pinched.

NOTICE Component damage hazard. The secondary boom cable track can be damaged if it is twisted.

Note: During removal, the overhead crane strap will need to be adjusted for proper balancing.

How to Repair the Secondary Boom Cable Track

NOTICE Component damage hazard. The boom cable track can be damaged if it is twisted.

Note: A cable track repair kit is available through the Genie Service Parts Department.

- 1 Remove the secondary boom cable track. Refer to Repair Procedure, *How to Remove the Secondary Boom Cable Track*.
- 2 Visually inspect the cable track and determine which 4-link section needs to be replaced.
- 3 Carefully remove the snap rings and pins from each end of the damaged section of cable track.
- 4 Remove the retaining fasteners from the upper black rollers from the 4-link section of cable track to be replaced. Remove the rollers.
- 5 Lift up the hoses and cables and carefully remove the damaged 4-link section of cable track.

NOTICE Component damage hazard. Cables and hoses can be damaged if they are kinked or pinched.

Note: If the section of cable track being replaced has clamps or wear pads, those items will need to be transferred to the replacement section of cable track.

Boom Components

- 6 Remove the upper rollers from the replacement section of cable track.
- 7 Lift up the hoses and cables and carefully insert the new 4-link section of cable track.

NOTICE Component damage hazard. Cables and hoses can be damaged if they are kinked or pinched.

- 8 Connect the ends of the replacement cable track section to the existing cable track using the pins and snap rings.
- 9 Install the rollers onto the new section of cable track.
- 10 Install the secondary boom cable track into the secondary boom.
- 11 Operate the secondary boom up/extend and down/retract functions through a full cycle to ensure smooth operation of the new section of cable track.

4-3 Primary Boom

How to Remove the Primary Boom

WARNING Bodily injury hazard. This procedure requires specific repair skills, lifting equipment and a suitable workshop. Attempting this procedure without these skills and tools could result in death or serious injury and significant component damage. Dealer service is strongly recommended.

Note: When removing a hose assembly or fitting, the O-ring (if equipped) on the fitting and/or hose end must be replaced. All connections must be torqued to specification during installation. Refer to Specifications, *Hydraulic Hose and Fitting Torque Specifications*.

Note: Perform this procedure with the boom in the stowed position.

- 1 Remove the platform.
- 2 Remove the platform mounting weldment and the platform rotator. Refer to Repair Procedure, *How to Remove the Platform Rotator*.
- 3 Remove the jib boom. Refer to Repair Procedure, *How to Remove the Jib Boom*.

Note: When the jib boom is installed, the jib boom angle sensor will need to be calibrated. Refer to Repair Procedure, *How to Calibrate the Jib Boom Bellcrank Angle Sensor*.

Boom Components

- 4 Remove the primary boom cable track. Refer to repair procedure, *How to Remove the Cable Track*.
- 5 Remove the end cover from the pivot end of the primary boom.
- 6 Remove the limit switch mounting fasteners from the limit switch on the ground controls side of the primary boom. Do not disconnect the wiring. Remove the limit switch.
- 7 Disconnect the electrical connector from the primary boom angle sensor.

Note: The primary boom angle sensor is located inside the primary boom at the pivot end.

- 8 Remove the primary boom angle sensor bracket mounting fasteners and remove the primary boom angle sensor from the primary boom. Do not remove the angle sensor from the bracket. Note the location of the springs. Do not lose the springs.

Note: There is one spring inside the primary boom pivot pin and one inside the angle sensor.

Note: When the primary boom is installed, the primary boom angle sensor will need to be calibrated. Refer to Repair Procedure, *How to Calibrate the Primary Boom Angle Sensor*.

- 9 Remove the hose and cable guide fasteners at the primary boom pivot pin. Remove the hose and cable guide.

- 10 Tag, disconnect and plug the primary boom extension cylinder hydraulic hoses. Cap the fittings on the cylinder.

⚠ WARNING

Bodily injury hazard. Spraying hydraulic oil can penetrate and burn skin. Loosen hydraulic connections very slowly to allow the oil pressure to dissipate gradually. Do not allow oil to squirt or spray.

- 11 Place blocks under both ends of the primary boom lift cylinder for support.
- 12 Attach a lifting strap from an overhead crane to the rod end of the primary boom lift cylinder.
- 13 Remove the pin retaining fasteners from the primary boom lift cylinder rod-end pivot pin.
- 14 Use a soft metal drift to remove the rod-end pivot pin. Rest the rod end of the primary boom lift cylinder on the blocks.
- 15 Support both upper primary boom lift cylinder linkage arms with a suitable lifting device. Do not apply any lifting pressure.
- 16 Remove the pin retaining fasteners from the upper primary boom lift cylinder linkage arm pivot pin where it connects to the primary boom.

Boom Components

- 17 Use a soft metal drift to tap the pin halfway out and lower one of the linkage arms down. Tap the pin in the other direction and lower the other linkage arm down.

CAUTION Crushing hazard. The upper primary boom lift cylinder linkage arms could fall if not properly supported when the pivot pins are removed.

- 18 Attach a 5 ton / 5000 kg overhead crane to both ends of the primary boom. Do not apply any lifting pressure.
- 19 Remove the pin retaining fasteners from the primary boom pivot pins.
- 20 Use a soft metal drift to remove the primary boom pivot pins.
- 21 Carefully remove the primary boom from the machine and place it on a structure capable of supporting it.

WARNING Crushing hazard. The primary boom could become unbalanced and fall when removed from the machine if not properly attached to the overhead crane.

4-4

Primary Boom Lift Cylinder

The primary boom lift cylinder raises and lowers the primary boom. The primary boom lift cylinder is equipped with a counterbalance valve to prevent movement in the event of a hydraulic line failure.

How to Remove the Primary Boom Lift Cylinder

WARNING Bodily injury hazard. This procedure requires specific repair skills, lifting equipment and a suitable workshop. Attempting this procedure without these skills and tools could result in death or serious injury and significant component damage. Dealer service is strongly recommended.

Note: When removing a hose assembly or fitting, the O-ring (if equipped) on the fitting and/or hose end must be replaced. All connections must be torqued to specification during installation. Refer to *Specifications, Hydraulic Hose and Fitting Torque Specifications*.

Note: Perform this procedure with the boom in the stowed position.

- 1 Remove the hose and cable clamps from the primary boom lift cylinder.
- 2 Remove the cable track retaining fasteners at the primary boom lift cylinder.
- 3 Place blocks under both ends of the primary boom lift cylinder. Place another block under the cylinder linkage arms under the primary boom lift cylinder barrel-end pivot pin.

Boom Components

- 4 Tag, disconnect and plug the primary boom lift cylinder hydraulic hoses. Cap the fittings on the cylinder.

⚠ WARNING Bodily injury hazard. Spraying hydraulic oil can penetrate and burn skin. Loosen hydraulic connections very slowly to allow the oil pressure to dissipate gradually. Do not allow oil to squirt or spray.

- 5 Attach a lifting strap from an overhead crane to the rod end of the primary boom lift cylinder. Do not apply any lifting pressure.
- 6 Remove the pin retaining fasteners from the primary boom lift cylinder rod-end pivot pin. Use a soft metal drift to remove the pin and rest the cylinder on the block.
- 7 Attach a lifting strap from a second overhead crane to the barrel end of the primary boom lift cylinder. Do not apply any lifting pressure.
- 8 Remove the primary boom lift cylinder barrel-end pivot pin retaining fasteners.
- 9 Use a soft metal drift to remove the barrel-end pivot pin. Carefully remove the primary boom lift cylinder from the machine.

⚠ WARNING Crushing hazard. The boom lift cylinder may become unbalanced and fall if it is not properly supported when it is removed from the machine.

⚠ WARNING Crushing hazard. The primary boom lift cylinder linkage arms may fall if not properly supported when the barrel-end pivot pin is removed.

4-5 Secondary Boom Lift Cylinder

How to Remove the Secondary Boom Lift Cylinder

⚠ WARNING Bodily injury hazard. This procedure requires specific repair skills, lifting equipment and a suitable workshop. Attempting this procedure without these skills and tools could result in death or serious injury and significant component damage. Dealer service is strongly recommended.

Note: When removing a hose assembly or fitting, the O-ring (if equipped) on the fitting and/or hose end must be replaced. All connections must be torqued to specification during installation. Refer to Specifications, *Hydraulic Hose and Fitting Torque Specifications*.

Note: Perform this procedure with the machine on a firm, level surface and in the stowed position with the axles extended.

- 1 Tag, disconnect and plug the hydraulic hoses from the secondary boom lift cylinder. The hoses can be accessed from under the turntable.

⚠ WARNING Bodily injury hazard. Spraying hydraulic oil can penetrate and burn skin. Loosen hydraulic connections very slowly to allow the oil pressure to dissipate gradually. Do not allow oil to squirt or spray.

Boom Components

- Remove the engine pivot plate retaining fastener. Swing the engine pivot plate out away from the machine.

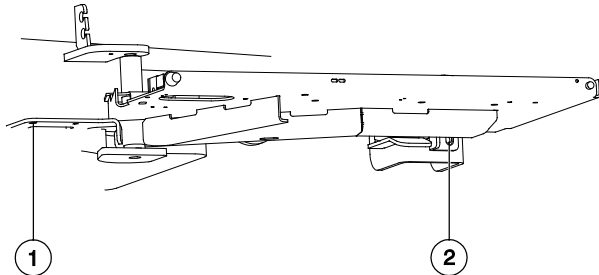

- engine pivot plate anchor hole
- engine pivot plate retaining fastener

- Locate the engine pivot plate anchor hole at the pivot end of the engine pivot plate.
- Install the bolt that was just removed into the anchor hole to secure the engine pivot plate from moving.

WARNING

Crushing hazard. Failure to install the bolt into the engine pivot plate to secure it from moving could result in death or serious injury.

- Remove the retaining fasteners from the fixed turntable cover at the ground controls side of the machine. Remove the fixed turntable cover from the machine.

- Tag, disconnect and plug the fuel hoses from the fuel tank. Clean up any fuel that may have spilled.
- Close the two hydraulic tank shut-off valves at the hydraulic tank.

NOTICE

Component damage hazard. The engine must not be started with the hydraulic tank shut-off valves in the closed position or component damage will occur. If the tank valves are closed, remove the key from the key switch and tag the machine to inform personnel of the condition.

- Remove the drain plug from the hydraulic tank and completely drain the tank into a container of suitable capacity. Refer to Specifications, *Fluid Capacity Specifications*.
- Tag, disconnect and plug the two suction hoses from the hydraulic tank.
- Tag, disconnect and plug the two supply hoses for the auxiliary power units. Cap the fittings on the hydraulic tank.
- Tag, disconnect and plug the hydraulic hose from the drive motor case drain filter at the hydraulic tank. Cap the fitting on the hydraulic tank.
- Tag, disconnect and plug the hydraulic hose at the return filter. Cap the fitting on the return filter housing.

Boom Components

- 13 Remove the turntable cover using a suitable lifting device.

⚠ WARNING Crushing hazard. The turntable cover may become unbalanced and fall if not properly supported and secured to a suitable lifting device.

- 14 Remove the ground control box mounting fasteners. Move the ground control box out of the way.
- 15 Remove the hydraulic tank retaining fasteners.
- 16 Remove the cover from the auxiliary power unit batteries.
- 17 Tag and disconnect the cables from the auxiliary power unit batteries.

⚠ WARNING Electrocutation/burn hazard. Contact with electrically charged circuits could result in death or serious injury. Remove all rings, watches and other jewelry.

- 18 Tag and disconnect the cables from the engine starting/controls battery located on the engine side of the machine.

⚠ WARNING Electrocutation/burn hazard. Contact with electrically charged circuits could result in death or serious injury. Remove all rings, watches and other jewelry.

- 19 Attach an overhead crane or similar lifting device to the battery box for the auxiliary power unit batteries.

- 20 Remove the battery box retaining fasteners and carefully remove the battery box from the machine.

⚠ WARNING Crushing hazard. The battery box could become unbalanced and fall when removed from the machine if not properly supported.

⚠ WARNING Bodily injury hazard. Batteries contain acid. Avoid spilling or contacting battery acid. Neutralize battery acid spills with baking soda and water.

- 21 Support the hydraulic tank with 2 lifting straps. Place one lifting strap at each end of the tank and attach the lifting straps to an appropriate lifting device.

- 22 Remove the hydraulic tank from the machine.

⚠ WARNING Crushing hazard. The hydraulic tank could become unbalanced and fall if not properly supported when removed from the machine.

- 23 Place a block under the secondary boom lift cylinder for support.

Boom Components

- 24 Remove the secondary boom lift cylinder rod-end pivot pin retaining fasteners. Use a soft metal drift to remove the pin through the access holes in the turntable bulkheads.
- 25 Attach an overhead crane with a minimum capacity of 7 tons / 7000 kg to the counterweight end of the secondary boom.
- 26 Raise the boom assembly with the overhead crane approximately 20 feet / 6 m.

⚠ DANGER

Crushing hazard. The boom assembly can fall if not properly supported by the overhead crane.

- 27 Remove the secondary boom lift cylinder barrel-end pivot pin retaining fasteners. Do not remove the pin.
- 28 Attach a lifting strap from a second overhead crane to each end of the secondary boom lift cylinder.

Note: Protect the hoses and cables underneath the cylinder from damage.

- 29 Use a slide hammer to remove the barrel-end pivot pin.

NOTICE

Component damage hazard. Hoses and cables can become damaged if the barrel end of the secondary boom lift cylinder is allowed to fall when the barrel-end pivot pin is removed.

- 30 Carefully remove the secondary boom lift cylinder from the machine.

⚠ WARNING

Crushing hazard. The secondary boom lift cylinder could become unbalanced and fall when removed from the machine if not properly attached to the overhead crane.

NOTICE

Component damage hazard. Hoses and cables can be damaged if the secondary boom lift cylinder is pulled across them.

Boom Components

4-6 Primary Boom Extension Cylinder

The primary boom extension cylinder extends and retracts the primary boom extension tube. The primary boom extension cylinder is equipped with counterbalance valves to prevent movement in the event of a hydraulic line failure.

How to Remove the Primary Boom Extension Cylinder

⚠ WARNING Bodily injury hazard. This procedure requires specific repair skills, lifting equipment and a suitable workshop. Attempting this procedure without these skills and tools could result in death or serious injury and significant component damage. Dealer service is strongly recommended.

Note: When removing a hose assembly or fitting, the O-ring (if equipped) on the fitting and/or hose end must be replaced. All connections must be torqued to specification during installation. Refer to Specifications, *Hydraulic Hose and Fitting Torque Specifications*.

Note: Perform this procedure with the machine on a firm, level surface and in the stowed position with the axles extended.

- 1 Extend the primary boom until the primary boom extension cylinder rod-end pivot pin is accessible in the primary boom extension tube.

- 2 Remove the access cover from the pivot end of the primary boom.
- 3 Tag, disconnect and plug the primary boom extension cylinder hydraulic hoses. Cap the fittings on the cylinder.

⚠ WARNING Bodily injury hazard. Spraying hydraulic oil can penetrate and burn skin. Loosen hydraulic connections very slowly to allow the oil pressure to dissipate gradually. Do not allow oil to squirt or spray.

- 4 At the platform end, remove the external snap rings from the extension cylinder rod-end pivot pin. Use a soft metal drift to remove the pin.
- 5 Remove the extension cylinder retainers from the saddle blocks.
- 6 Attach a lifting strap from an overhead crane to the barrel end of the primary boom extension cylinder.
- 7 Using the overhead crane, lift the extension cylinder to clear the saddle blocks.
- 8 Support and slide the primary boom extension cylinder out of the primary boom and place it on a structure capable of supporting it.

⚠ WARNING Crushing hazard. The extension cylinder could become unbalanced and fall when removed from primary boom extension tube if not properly supported.

Note: During removal, the overhead crane strap will need to be adjusted for proper balancing.

Note: Note the length of the cylinder after removal. The cylinder must be at the same length for installation.

Boom Components

4-7 Secondary Boom Extension Cylinders

The secondary boom extension cylinders extend and retract the secondary boom. The secondary boom extension system consists of 3 hydraulic cylinders and each are equipped with counterbalance valves to prevent movement in the event of a hydraulic line failure.

How to Remove the Secondary Boom Extension Cylinders

▲WARNING Bodily injury hazard. This procedure requires specific repair skills, lifting equipment and a suitable workshop. Attempting this procedure without these skills and tools could result in death or serious injury and significant component damage. Dealer service is strongly recommended.

Note: When removing a hose assembly or fitting, the O-ring (if equipped) on the fitting and/or hose end must be replaced. All connections must be torqued to specification during installation. Refer to Specifications, *Hydraulic Hose and Fitting Torque Specifications*.

Note: Perform this procedure with the machine on a firm, level surface and in the stowed position with the axles extended.

- 1 Raise the primary boom approximately 10 feet / 3 m. Turn the machine off.
- 2 Working at the platform end of the secondary boom, support and secure the secondary boom end cover to a suitable lifting device.
- 3 Remove the cover retaining fasteners and remove the cover from the secondary boom.

▲WARNING Crushing hazard. The secondary boom end cover could become unbalanced and fall when removed from the secondary boom if not properly supported and secured to the lifting device.

- 4 Remove the retaining fasteners from both secondary boom extend limit switches and remove the limit switches. Do not disconnect the wiring.

Note: Label the location of each limit switch as they are not the same and their mounting locations cannot be exchanged.

- 5 Tag, disconnect and plug all hydraulic hoses for the 3 secondary boom extension cylinders. Cap the fittings on the cylinder.

▲WARNING Bodily injury hazard. Spraying hydraulic oil can penetrate and burn skin. Loosen hydraulic connections very slowly to allow the oil pressure to dissipate gradually. Do not allow oil to squirt or spray.

- 6 Remove the upper extension cylinder retainers from the saddle blocks.

Boom Components

- 7 Attach a lifting strap from an overhead crane to the rod end of the upper extension cylinder.
- 8 Using the overhead crane, lift the extension cylinder to clear the saddle blocks.
- 9 Support and slide the upper extension cylinder out of the secondary boom and place it on a structure capable of supporting it.

WARNING

Crushing hazard. The extension cylinder could fall when removed from the secondary boom if not properly supported.

Note: During removal, the overhead crane strap will need to be adjusted for proper balancing.

- 10 Repeat steps 6 through 9 for the remaining secondary boom extension cylinders.

Note: The secondary boom extension cylinders must be installed in the same order they were removed.

Note: When installing the middle and upper secondary boom extension cylinders, be sure the grooved wear pads are correctly aligned with the channels on the top of the cylinders.

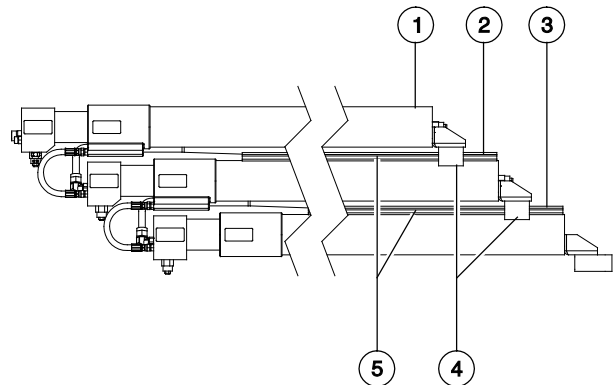

- 1 upper extension cylinder (#1)
- 2 middle extension cylinder (#2)
- 3 bottom extension cylinder (#3)
- 4 cylinder grooved wear pads
- 5 channels

Boom Components

4-8 Primary Boom Angle Sensor

The primary boom angle sensor is used to limit the angle of the primary boom relative to the angle of the secondary boom and gravity.

How to Replace the Primary Boom Angle Sensor

Note: Perform this procedure with the machine on a firm, level surface with the boom in the stowed position.

- 1 Remove the retaining fasteners from the boom end cover at the pivot end of the primary boom. Remove the cover from the machine.
- 2 Locate the primary boom angle sensor inside the primary boom at the boom pivot pin.
- 3 Disconnect the electrical connector from the sensor.
- 4 Remove the angle sensor mounting bracket retaining fasteners.
- 5 Remove the angle sensor and bracket assembly. Do not lose the two springs or the hex-shaped key.
- 6 Remove the sensor retaining fasteners from the mounting bracket. Remove the angle sensor.

Note: Note the sensor orientation on the bracket during removal so the new sensor will be installed in the same position.

- 7 Install the new angle sensor onto the mounting bracket.
- 8 Install one spring, removed in step 5, into the hex-shaped hole in the angle sensor. Install the other spring into the hex-shaped hole in the center of the boom pivot pin.
- 9 Insert the hex-shaped key into the angle sensor.
- 10 Align the side of the sensor with flat area of the boom pivot pin as shown below while holding the bracket away from key insertion.

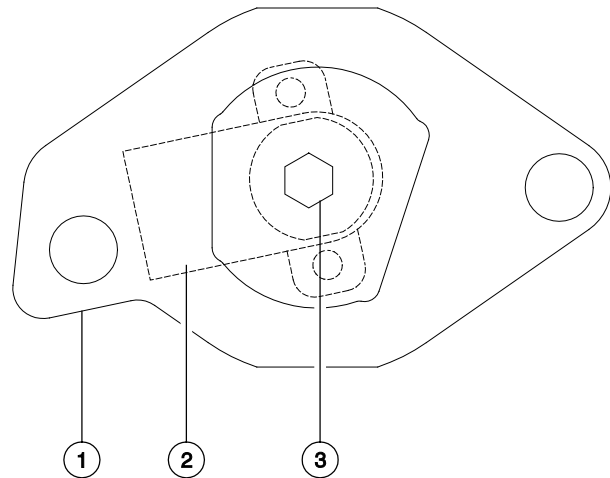

- 1 flat area
- 2 angle sensor
- 3 hex-shaped hole

Boom Components

- 11 While holding the hex-shaped key in position, rotate the angle sensor mounting bracket clockwise until it aligns with the machined pocket. Do not allow the key to rotate while holding it.
- 12 Insert the hex-shaped key into the boom pivot pin and the bracket into the machined pocket.

Note: Be sure the hex-shaped key remains engaged in the sensor.

- 13 Install the angle sensor bracket retaining fasteners.
- 14 Connect the electrical connector to the new sensor.
- 15 Install the primary boom end cover.
- 16 Calibrate the primary boom angle sensor. Refer to Repair Procedure, *How to Calibrate the Primary Boom Angle Sensor*.

How to Calibrate the Primary Boom Angle Sensor

The primary boom angle sensor is used to limit the angle of the primary boom relative to the angle of the secondary boom and gravity.

The primary boom maximum angle is gradually reduced as the downhill slope (positive degree Y axis) is increased. A flat level surface of 0° allows the primary boom maximum operational angle to reach 68°. On a 5° downhill slope the primary boom maximum operational angle is reduced to 43°.

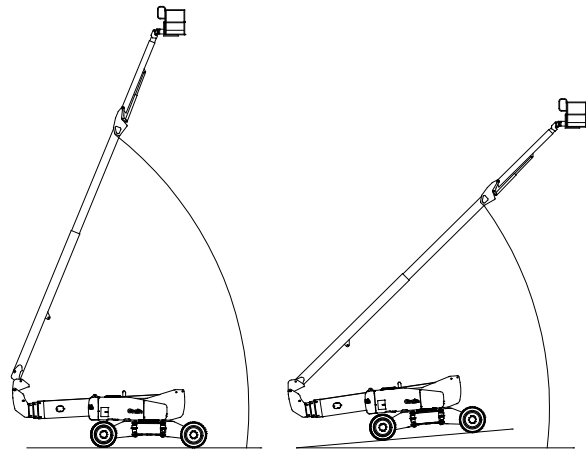

0° slope, 68° boom angle

5° slope, 43° boom angle

Boom Components

Note: If the axle sensor or secondary boom angle sensor have been removed or replaced, or the turntable level sensor has been replaced, they must be calibrated first. Refer to Repair Procedures, *How to Calibrate the Axle Angle Sensors* or *How to Calibrate the Secondary Boom Angle Sensor* or *How to Calibrate the Turntable Level Sensor*.

⚠ WARNING

Tip-over hazard. Failure to properly calibrate the machine could cause the machine to tip over resulting in death or serious injury.

Note: For software versions 4.01 and higher, use the 2 Point Calibration procedure. For software versions before 4.01, use the 6 Point Calibration procedure. The software version is displayed on the LCD screen when the red Emergency Stop button is pulled out to the on position.

Note: A digital level will only be required to perform the 6 Point Calibration procedure.

Note: A kit is available through Genie Product Support (Genie part number 58351). This kit includes a digital level with a magnetic base and cable harnesses.

Note: Use the following chart to identify the description of each LCD screen control button used in this procedure.



Plus



Minus



Previous



Enter

Note: Perform this procedure with the machine on a firm, level surface with the booms in the fully stowed position, in the drive enable zone and the axles fully extended.

6 Point Calibration procedure

Note: Use this procedure for software versions before 4.01.

Note: For the 2 Point Calibration procedure, proceed to step 37.

- 1 Push in the ground controls red Emergency Stop button to the off position. Do not turn the key switch to the off position.
- 2 Turn the key switch to ground controls.
- 3 Open the ground control box.

Before serial number 321:

- 4 Locate the 2 pin connector in the lower left hand area of the ground control box.
- 5 Remove the connector plug and insert a jumper wire between the two pins of the connector.

After serial number 320:

- 6 Locate the calibration toggle switch at the top of the ground control box. Activate calibration mode by moving the toggle switch in the left direction.
- 7 Temporarily install a control box door retaining fastener between the door and the box to prevent the control box door from moving the toggle switch while calibrating the machine.

All models:

- 8 Remove the key from the main key switch. Insert the key into the bypass/recovery key switch and turn it to the bypass position.

Note: The angle sensor calibration values will not be saved correctly unless the key switch is in the bypass position and the calibration toggle switch is activated.

Boom Components

- 9 Press and hold the **enter** button on the ground control panel while pulling out the ground controls red Emergency Stop button to the on position. Hold the **enter** button for approximately 5 seconds and then release it.
- 10 Enter sensor calibration mode by pressing the buttons at the ground controls in the following sequence: **(plus)(enter)(enter)(plus)**.
- 11 Press the **enter** or **previous** button on the LCD screen until DELETE PRIMARY BOOM ANGLE SENSOR CALIBRATION is displayed.
- 12 Press the **plus** button to select YES, then press the **enter** button to accept.
- 13 Place a digital level that has been calibrated to gravity on top of the primary boom and note the angle displayed on the digital level.
- 14 At the PRIMARY BOOM ANGLE TO GRAVITY 0.0 DEG screen, press the **plus** button or **minus** button to adjust the display to the exact value shown on the digital level, then press the **enter** button.

Note: If the measured angle already matches the angle shown on the display at the ground controls, press the **plus** button or **minus** button to change the angle and then change back to the measured value. The system must detect a change in displayed value to record the calibrated value.
- 15 Start the engine from the ground controls.

Note: If the system exits out of calibration mode when the engine is started, repeat step 8 and then continue with step 14.
- 16 Fully raise the secondary boom. The boom is fully raised when the cylinder is fully extended and the boom stops moving.
- 17 Press and hold a function enable/speed select button and the primary boom down button and lower the primary boom down until the digital level displays -50 degrees.
- 18 At the ground controls, press the **plus** button or **minus** button to adjust the display to the exact value shown on the digital level and press the **enter** button.

Note: Be sure the number entered at the ground controls is a negative number.

Note: If the measured angle already matches the angle shown on the display at the ground controls, press the **plus** button or **minus** button to change the angle and then change back to the measured value. The system must detect a change in displayed value to record the calibrated value.
- 19 Press and hold a function enable/speed select button and the primary boom up button until the digital level displays -20 degrees.
- 20 At the ground controls, press the **plus** button or **minus** button to adjust the display to the exact value shown on the digital level and press the **enter** button.

Note: Be sure the number entered at the ground controls is a negative number.

Note: If the measured angle already matches the angle shown on the display at the ground controls, press the **plus** button or **minus** button to change the angle and then change back to the measured value. The system must detect a change in displayed value to record the calibrated value.
- 21 Press and hold a function enable/speed select button and the primary boom up button until the digital level displays 10 degrees.

Boom Components

- 22 At the ground controls, press the **plus** button or **minus** button to adjust the display to the exact value shown on the digital level and press the **enter** button.

Note: If the measured angle already matches the angle shown on the display at the ground controls, press the **plus** button or **minus** button to change the angle and then change back to the measured value. The system must detect a change in displayed value to record the calibrated value.

- 23 Press and hold a function enable/speed select button and the primary boom up button until the digital level displays 40 degrees.

- 24 At the ground controls, press the **plus** button or **minus** button to adjust the display to the exact value shown on the digital level and press the **enter** button.

Note: If the measured angle already matches the angle shown on the display at the ground controls, press the **plus** button or **minus** button to change the angle and then change back to the measured value. The system must detect a change in displayed value to record the calibrated value.

- 25 Press and hold a function enable/speed select button and the primary boom up button until the primary boom is fully raised. The boom is fully raised when the cylinder is fully extended and the boom stops moving. The angle will be 70 degrees.

- 26 At the ground controls, press the **plus** button or **minus** button to adjust the display to the exact value shown on the digital level and press the **enter** button.

Note: If the measured angle already matches the angle shown on the display at the ground controls, press the **plus** button or **minus** button to change the angle and then change back to the measured value. The system must detect a change in displayed value to record the calibrated value.

- 27 Press and hold the engine start button for approximately 5 seconds to shut off the engine and to save the calibration settings.

Note: Do not turn the engine off with the key switch or red Emergency Stop button or all calibration points or values will not be saved.

- 28 Press the **enter** or **previous** button on the LCD screen until EXIT is displayed.
- 29 Press the **plus** button to select YES, then press the **enter** button to accept.
- 30 Turn the key back to the run position and remove the key from the bypass/recovery key switch. Insert the key into the main key switch and turn it to ground controls.

Note: Be sure that the bypass/recovery key switch is in the run position before attempting to operate the machine.

- 31 Wait approximately 20 seconds and turn the machine off by pressing the red Emergency Stop button in.

Before serial number 321

- 32 Remove the wire jumper from the 2 pin connector in the lower left hand area of the ground control box that was installed in step 5. Install the connector plug.

DANGER

Tip-over hazard. Failure to remove the jumper wire will result in an unsafe configuration which will compromise machine stability. Operating the machine in this configuration will result in the machine tipping over, resulting in death or serious injury. The jumper wire must be removed before operating the machine.

- 33 Close the ground control box and install the door retaining fasteners.

Boom Components

After serial number 320:

- 34 Remove the fastener that was temporarily installed. Close the control box door and install the door retaining fasteners.

Note: When the control box door is closed, the calibration toggle switch is automatically activated to exit out of calibration mode.

All models:

- 35 Pull out the red Emergency Stop button. Start the engine and lower the boom to the stowed position. Be sure there are no calibration faults shown on the display.
- 36 Perform a primary boom angle test. Refer to Maintenance Procedure in the appropriate Service or Maintenance Manual, *Test the Primary Boom Angle Sensor*.

2 Point Calibration procedure

Note: Use this procedure for software versions 4.01 and higher.

- 37 Push in the ground controls red Emergency Stop button to the off position. Do not turn the key switch to the off position.
- 38 Turn the key switch to ground controls.
- 39 Open the ground control box.
- 40 Locate the calibration toggle switch at the top of the ground control box. Activate calibration mode by moving the toggle switch in the left direction.
- 41 Temporarily install a control box door retaining fastener between the door and the box to prevent the control box door from moving the toggle switch while calibrating the machine.
- 42 Remove the key from the main key switch. Insert the key into the bypass/recovery key switch and turn it to the bypass position.
- 43 Note: The angle sensor calibration values will not be saved correctly unless the key switch is in the bypass position and the calibration toggle switch is activated.
- 44 Press and hold the **enter** button on the ground control panel while pulling out the ground controls red Emergency Stop button to the on position. Hold the **enter** button for approximately 5 seconds and then release it.
- 45 Enter sensor calibration mode by pressing the buttons at the ground controls in the following sequence: **(plus)(enter)(enter)(plus)**.
- 46 Press the **enter** or **previous** button on the LCD screen until DELETE PRIMARY BOOM ANGLE SENSOR CALIBRATION is displayed.

Boom Components

- 47 Press the **plus** button to select YES, then press the **enter** button to accept.
 - 48 Lower the primary boom to the stowed position.
 - 49 Press the **enter** or **previous** button on the LCD SCREEN UNTIL PRIMARY BOOM FULLY LOWERED is displayed.
 - 50 Press the **plus** button to select YES, then press the **enter** button to accept.
 - 51 Fully raise the secondary boom until it stops at the end of the cylinder stroke.
 - 52 Fully raise the primary boom until it stops at the end of the cylinder stroke.
 - 53 Press the **enter** or **previous** button on the LCD screen until PRIMARY BOOM FULLY RAISED is displayed.
 - 54 Press the **plus** button to select YES, then press the **enter** button to accept.
 - 55 Press and hold the engine start button for approximately 5 seconds to shut off the engine and to save the calibration settings.
- Note: Do not turn the engine off with the key switch or red Emergency Stop button or all calibration points or values will not be saved.
- 56 Press the **enter** or **previous** button on the LCD screen until EXIT is displayed.
 - 57 Press the **plus** button to select YES, then press the **enter** button to accept.
 - 58 Turn the key back to the run position and remove the key from the bypass/recovery key switch. Insert the key into the main key switch and turn it to ground controls.
- Note: Be sure that the bypass/recovery key switch is in the run position before attempting to operate the machine.
- 59 Wait approximately 20 seconds and turn the machine off by pressing the red Emergency Stop button in.
 - 60 Remove the fastener that was temporarily installed. Close the control box door and install the door retaining fasteners.
- Note: When the control box door is closed, the calibration toggle switch is automatically activated to exit out of calibration mode.
- 61 Pull out the red Emergency Stop button. Start the engine and lower the boom to the stowed position. Be sure there are no calibration faults shown on the display.
 - 62 Perform a primary boom angle test. Refer to Maintenance Procedure in the appropriate Service or Maintenance Manual, *Test the Primary Boom Angle Sensor*.

Boom Components

4-9 Secondary Boom Angle Sensor

The secondary boom angle sensor is used to limit the angle of the primary boom relative to the angle of the secondary boom and gravity.

How to Replace the Secondary Boom Angle Sensor

Note: Perform this procedure with the machine on a firm, level surface with the boom in the stowed position.

- 1 Locate the secondary boom angle sensor on the turntable riser bulkhead at the ground controls side of the machine.
- 2 Disconnect the electrical connector from the sensor. Remove any tie wraps securing the wiring.
- 3 Remove the angle sensor cover retaining fastener. Remove the cover.
- 4 Remove the angle sensor mounting bracket retaining fasteners.
- 5 Remove the angle sensor and bracket assembly. Do not lose the two springs or the hex-shaped key.
- 6 Remove the sensor retaining fasteners from the mounting bracket. Remove the angle sensor.
- 7 Install the new angle sensor onto the mounting bracket.
- 8 Install one spring, removed in step 5, into the hex-shaped hole in the angle sensor. Install the other spring into the hex-shaped hole in the center of the boom pivot pin.
- 9 Insert the hex-shaped key into the angle sensor.
- 10 Align the side of the sensor with flat area of the boom pivot pin as shown below. Hold the bracket out to clear the side of the turntable side plate.

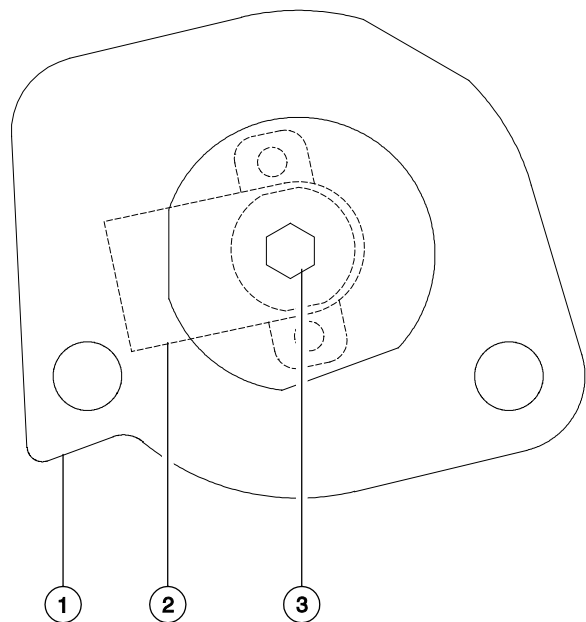

- 1 flat area
- 2 angle sensor
- 3 hex-shaped hole

Note: Note the sensor orientation on the bracket during removal so the new sensor will be installed in the same position.

Boom Components

- 11 While holding the hex-shaped key in position, rotate the angle sensor mounting bracket clockwise until it aligns with the machined pocket. Do not allow the key to rotate while holding it.

Note: Be sure the hex-shaped key remains engaged in the sensor only.

- 12 Insert the hex-shaped key into the boom pivot pin and the bracket into the machined pocket.
- 13 Install the angle sensor bracket retaining fasteners.
- 14 Install the angle sensor cover and retaining fasteners.
- 15 Connect the electrical connector to the new sensor.
- 16 Calibrate the secondary boom angle sensor. Refer to Repair Procedure, *How to Calibrate the Secondary Boom Angle Sensor*.

How to Calibrate the Secondary Boom Angle Sensor

Note: If the axle sensor has been removed or replaced, or the turntable level sensor has been replaced, they must be calibrated first. Refer to Repair Procedure, *How to Calibrate the Axle Angle Sensors* or *How to Calibrate the Turntable Level Sensor*.

⚠ WARNING

Tip-over hazard. Failure to properly calibrate the machine could cause the machine to tip over resulting in death or serious injury.

Note: For software versions 4.01 and higher, use the 2 Point Calibration procedure. For software versions before 4.01, use the 6 Point Calibration Procedure. The software version is displayed on the LCD screen when the red Emergency Stop button is pulled out to the on position.

Note: A digital level will only be required to perform the 6 Point Calibration procedure.

Note: A kit is available through Genie Product Support (Genie part number 58351). This kit includes a digital level with a magnetic base and cable harnesses.

Note: Perform this procedure with the machine on a firm, level surface with the booms in the fully stowed position, in the drive enable zone and the axles fully extended.

Note: Use the following chart to identify the description of each LCD screen control button used in this procedure.



Plus



Minus



Previous



Enter

Boom Components

6 Point Calibration procedure

Note: Use this procedure for software versions before 4.01.

Note: For the 2 Point Calibration procedure, proceed to step 36.

- 1 Push in the ground controls red Emergency Stop button to the off position. Do not turn the key switch to the off position.
- 2 Turn the key switch to ground controls.
- 3 Open the ground control box.

Before serial number 321:

- 4 Locate the 2 pin connector in the lower left hand area of the ground control box.
- 5 Remove the connector plug and insert a jumper wire between the two pins of the connector.

After serial number 320:

- 6 Locate the calibration toggle switch at the top of the ground control box. Activate calibration mode by moving the toggle switch in the left direction.
- 7 Temporarily install a control box door retaining fastener between the door and the box to prevent the control box door from moving the toggle switch while calibrating the machine.

All models:

- 8 Remove the key from the main key switch. Insert the key into the bypass/recovery key switch and turn it to the bypass position.

Note: The angle sensor calibration values will not be saved correctly unless the key switch is in the bypass position and the calibration toggle switch is activated.

- 9 Press and hold the **enter** button on the ground control panel while pulling out the ground controls red Emergency Stop button to the on position. Hold the **enter** button for approximately 5 seconds and then release it.
- 10 Enter sensor calibration mode by pressing the buttons at the ground controls in the following sequence: **(plus)(enter)(enter)(plus)**.

Boom Components

- 11 Press the **enter** or **previous** button on the LCD screen until DELETE SECONDARY BOOM ANGLE SENSOR CALIBRATION is displayed.
- 12 Press the **plus** button to select YES, then press the **enter** button to accept.
- 13 Place a digital level that has been calibrated to the Y axis of the turntable on top of the secondary boom and note the angle displayed on the digital level.
- 14 At the SECONDARY BOOM ANGLE TO GRAVITY -3.5DEG screen, press the **plus** button or **minus** button to adjust the display to the exact value shown on the digital level and press the enter button.

Note: Be sure the number entered at the ground controls is a negative number.

Note: If the measured angle already matches the angle shown on the display at the ground controls, press the **plus** button or **minus** button to change the angle and then change back to the measured value. The system must detect a change in displayed value to record the calibrated value.

- 15 Start the engine from the ground controls.

Note: If the system exits out of calibration mode when the engine is started, repeat step 8 and then continue with step 14.

- 16 Press and hold a function enable/speed select button and the secondary boom up button until the digital level displays 20 degrees.

- 17 At the ground controls, press the **plus** button or **minus** button to adjust the display to the exact value shown on the digital level and press the **enter** button.

Note: If the measured angle already matches the angle shown on the display at the ground controls, press the **plus** button or **minus** button to change the angle and then change back to the measured value. The system must detect a change in displayed value to record the calibrated value.

- 18 Press and hold a function enable/speed select button and the secondary boom up button until the digital level displays 35 degrees.
- 19 At the ground controls, press the **plus** button or **minus** button to adjust the display to the exact value shown on the digital level and press the **enter** button.

Note: If the measured angle already matches the angle shown on the display at the ground controls, press the **plus** button or **minus** button to change the angle and then change back to the measured value. The system must detect a change in displayed value to record the calibrated value.

- 20 Press and hold a function enable/speed select button and the secondary boom up button until the digital level displays 50 degrees.
- 21 At the ground controls, press the **plus** button or **minus** button to adjust the display to the exact value shown on the digital level and press the **enter** button.

Note: If the measured angle already matches the angle shown on the display at the ground controls, press the **plus** button or **minus** button to change the angle and then change back to the measured value. The system must detect a change in displayed value to record the calibrated value.

Boom Components

- 22 Press and hold a function enable/speed select button and the secondary boom up button until the digital level displays 65 degrees.
- 23 At the ground controls, press the **plus** button or **minus** button to adjust the display to the exact value shown on the digital level and press the **enter** button.

Note: If the measured angle already matches the angle shown on the display at the ground controls, press the **plus** button or **minus** button to change the angle and then change back to the measured value. The system must detect a change in displayed value to record the calibrated value.

- 24 Press and hold a function enable/speed select button and the secondary boom up button. Fully raise the secondary boom. The boom is fully raised when the cylinder is fully extended and the boom stops moving. The angle will be 76 degrees.
- 25 At the ground controls, press the **plus** button or **minus** button to adjust the display to the exact value shown on the digital level and press the **enter** button.

Note: If the measured angle already matches the angle shown on the display at the ground controls, press the **plus** button or **minus** button to change the angle and then change back to the measured value. The system must detect a change in displayed value to record the calibrated value.

- 26 Press and hold the engine start button for approximately 5 seconds to shut off the engine and to save the calibration settings.

Note: Do not turn the engine off with the key switch or red Emergency Stop button or all calibration points or values will not be saved.

- 27 Press the **enter** or **previous** button on the LCD screen until EXIT is displayed.
- 28 Press the **plus** button to select YES, then press the **enter** button to accept.
- 29 Turn the key back to the run position and remove the key from the bypass/recovery key switch. Insert the key into the main key switch and turn it to ground controls.

Note: Be sure that the bypass/recovery key switch is in the run position before attempting to operate the machine.

- 30 Wait approximately 20 seconds and turn the machine off by pressing the red Emergency Stop button in.

Before serial number 321:

- 31 Remove the wire jumper from the 2 pin connector in the lower left hand area of the ground control box that was installed in step 5. Install the connector plug.

⚠ DANGER

Tip-over hazard. Failure to remove the jumper wire will result in an unsafe configuration which will compromise machine stability. Operating the machine in this configuration will result in the machine tipping over, resulting in death or serious injury. The jumper wire must be removed before operating the machine.

- 32 Close the ground control box and install the door retaining fasteners.

Boom Components

After serial number 320:

- 33 Remove the fastener that was temporarily installed. Close the control box door and install the door retaining fasteners.

Note: When the control box door is closed, the calibration toggle switch is automatically activated to exit out of calibration mode.

All models:

- 34 Pull out the red Emergency Stop button. Start the engine and lower the boom to the stowed position. Be sure there are no calibration faults shown on the display.
- 35 Perform secondary boom angle test. Refer to Maintenance Procedure in the appropriate Service or Maintenance Manual, *Test the Secondary Boom Angle Sensor*.

2 Point Calibration procedure

Note: Use this procedure for software versions 4.01 and higher.

- 36 Push in the ground controls red Emergency Stop button to the off position. Do not turn the key switch to the off position.
- 37 Turn the key switch to ground controls.
- 38 Open the ground control box.
- 39 Locate the calibration toggle switch at the top of the ground control box. Activate calibration mode by moving the toggle switch in the left direction.
- 40 Temporarily install a control box door retaining fastener between the door and the box to prevent the control box door from moving the toggle switch while calibrating the machine.
- 41 Remove the key from the main key switch. Insert the key into the bypass/recovery key switch and turn it to the bypass position.

Note: The angle sensor calibration values will not be saved correctly unless the key switch is in the bypass position and the calibration toggle switch is activated.

- 42 Press and hold the **enter** button on the ground control panel while pulling out the ground controls red Emergency Stop button to the on position. Hold the **enter** button for approximately 5 seconds and then release it. Enter sensor calibration mode by pressing the buttons at the ground controls in the following sequence:
(plus)(enter)(enter)(plus).

Boom Components

- 43 Press the **enter** or **previous** button on the LCD screen until DELETE SECONDARY BOOM ANGLE SENSOR CALIBRATION is displayed.
 - 44 Press the **plus** button to select YES, then press the **enter** button to accept.
 - 45 Lower the secondary boom to the stowed position.
 - 46 Press the **enter** or **previous** button on the LCD SCREEN UNTIL SECONDARY BOOM FULLY LOWERED is displayed.
 - 47 Press the **plus** button to select YES, then press the **enter** button to accept.
 - 48 Fully raise the secondary boom until it stops at the end of the cylinder stroke.
 - 49 Press the **enter** or **previous** button on the LCD SCREEN UNTIL SECONDARY BOOM FULLY RAISED is displayed.
 - 50 Press the **plus** button to select YES, then press the **enter** button to accept.
 - 51 Press and hold the engine start button for approximately 5 seconds to shut off the engine and to save the calibration settings.
- Note: Do not turn the engine off with the key switch or red Emergency Stop button or all calibration points or values will not be saved.
- 52 Press the **enter** or **previous** button on the LCD screen until EXIT is displayed.
 - 53 Press the **plus** button to select YES, then press the **enter** button to accept.
 - 54 Turn the key back to the run position and remove the key from the bypass/recovery key switch. Insert the key into the main key switch and turn it to ground controls.
- Note: Be sure that the bypass/recovery key switch is in the run position before attempting to operate the machine.
- 55 Wait approximately 20 seconds and turn the machine off by pressing the red Emergency Stop button in.
 - 56 Remove the fastener that was temporarily installed. Close the control box door and install the door retaining fasteners.
- Note: When the control box door is closed, the calibration toggle switch is automatically activated to exit out of calibration mode.
- 57 Pull out the red Emergency Stop button. Start the engine and lower the boom to the stowed position. Be sure there are no calibration faults shown on the display.
 - 58 Perform secondary boom angle test. Refer to Maintenance Procedure in the appropriate Service or Maintenance Manual, *Test the Secondary Boom Angle Sensor*.

Engines

5-1 RPM Adjustment

Refer to Maintenance Procedure in the appropriate Service or Maintenance Manual for your machine, *Check and Adjust the Engine RPM.*

5-2 Flex Plate

The flex plate acts as a coupler between the engine and the pump. It is bolted to the engine flywheel and has a splined center to drive the pump.

Two different styles of flex plates have been used in the production of your machine model.

Type "A" flex plates utilize a flex plate installed onto the flywheel of the engine and a separate coupler installed onto the pump splined shaft.

Type "B" flex plates combines the pump coupler, as part of the flex plate, which is installed onto the engine flywheel.

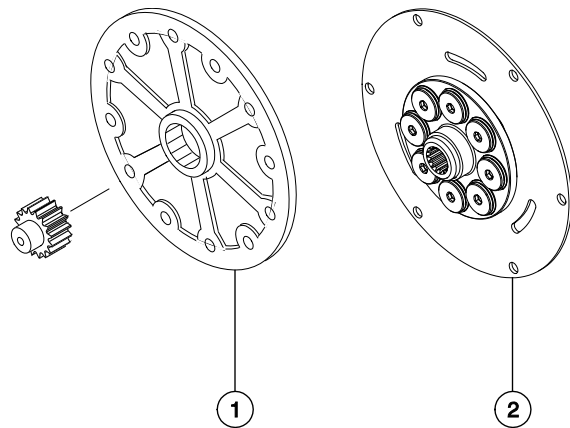

- 1 Type "A" (flex plate with separate coupler)
- 2 Type "B" (flex plate with coupler combined)

Engines

How to Remove the Flex Plate

- 1 Disconnect the wiring plug at the electronic displacement controller (EDC), located on the drive pump.
- 2 Support the drive pump with an appropriate lifting device. Then remove all of the pump mounting plate to engine bell housing bolts.
- 3 Carefully pull the pump away from the engine and secure it from moving.
- 4 Remove the flex plate mounting fasteners, then remove the flex plate from the engine flywheel.

How to Install a Type "A" Flex Plate

- 1 Install the flex plate onto the engine flywheel with the raised spline towards the pump.
- 2 **Ford models:** Torque the flex plate mounting bolts in sequence to 14 ft-lbs / 19 Nm. Then torque the flex plate mounting bolts in sequence to 20 ft-lbs / 27 Nm.

Deutz models: Torque the flex plate mounting bolts in sequence to 28 ft-lbs / 38 Nm. Then torque the flex plate mounting bolts in sequence to 40 ft-lbs / 54 Nm.

Perkins models: Torque the flex plate mounting bolts in sequence to 49 ft-lbs / 66 Nm. Then torque the flex plate mounting bolts in sequence to 70 ft-lbs / 95 Nm.

Engines

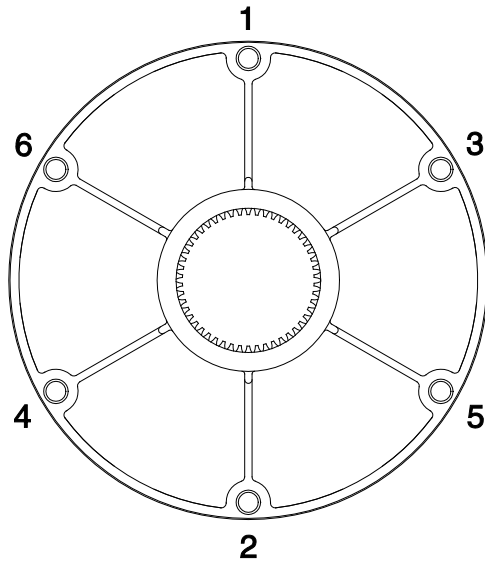

Ford and Deutz models

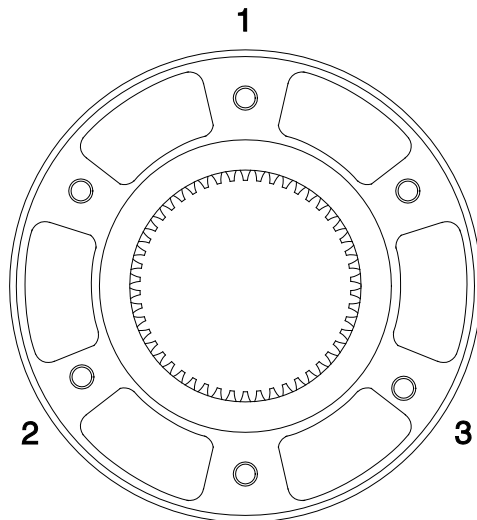

Perkins models

- 3 Install the pump coupler onto the pump shaft with the set screw toward the pump. Leave the appropriate gap between the coupler and pump end plate for your engine.

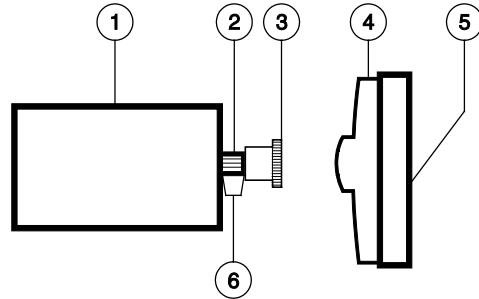

- 1 pump
- 2 pump shaft
- 3 pump coupler
- 4 flex plate with raised spline
- 5 engine flywheel
- 6 Deutz models - 0.188 inch / 4.8 mm gap
Cummins and Perkins models - 0.25 inch / 6.4 mm gap

- 4 **Cummins and Perkins models:** Apply Loctite® removable thread sealant to the pump coupler set screw. Torque the set screw to 22 ft-lbs / 30 Nm.

Deutz models: Apply Loctite® removable thread sealant to the pump coupler set screw. Torque the set screw to 61 ft-lbs / 83 Nm.

NOTICE Component damage hazard. Do not force the drive pump during installation or the flex plate teeth may become damaged.

Engines

How to Install a Type "B" Flex Plate

- 1 **Deutz and Perkins models:** Install the flex plate onto the engine flywheel with the rubber vibration isolators towards the pump.

Cummins models: Install the flex plate onto the engine flywheel with the rubber vibration isolators towards the engine flywheel.

- 2 Apply Loctite® removable thread sealant to the flex plate fasteners and loosely install the fasteners.
- 3 **Deutz and Perkins models:** Torque the flex plate mounting bolts in sequence to 28 ft-lbs / 38 Nm. Then torque the flex plate mounting bolts in sequence to 40 ft-lbs / 54 Nm.
- Cummins models:** Torque the flex plate mounting bolts in sequence to 14 ft-lbs / 19 Nm. Then torque the flex plate mounting bolts in sequence to 20 ft-lbs / 27 Nm.
- 4 Apply a high viscosity coupling grease (Genie part number 128025) to the splines of the pump shaft and flex plate.

Grease Specification

Shell Alvania® Grease CG, NLGI 0/1 or equivalent.

Deutz and Perkins models

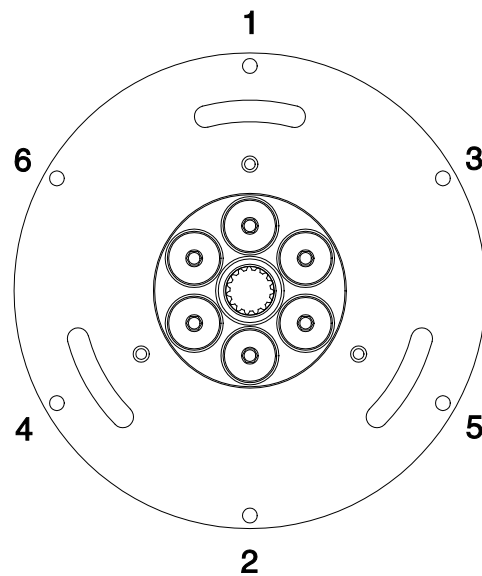

Cummins models

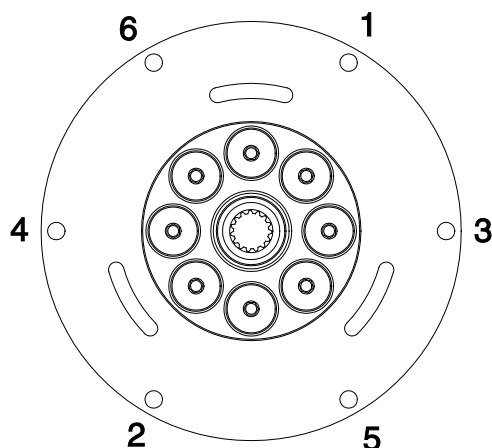

Ground Controls

6-1 Bypass/Recovery Key Switch

The turntable control box (TCON) is the communication and operations center for the machine. The turntable control box contains two key switches. The main key switch towards the top of the control box is for selection of ground or platform controls. The key switch at the bottom of the control box is the Bypass/Recovery key switch. Bypass and Recovery modes are only intended for certain circumstances and are not part of normal machine operation. If either the Bypass or the Recovery function is required, this indicates there may be faults with the machine. Contact trained personnel immediately.

Bypass is used for a platform out-of-level condition and calibrating certain machine parameters.

Recovery is only to be used as a last attempt to lower the platform when the operator in the platform is unable to do so, system failure or in emergency situations.

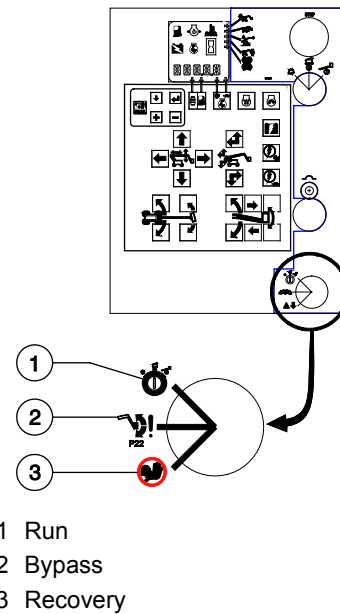

- 1 Run
- 2 Bypass
- 3 Recovery

Note: The bypass/recovery key switch is located on the lower right side of the control box from serial number Z13512-1712.

Ground Controls

How to Use the Bypass Mode

⚠ DANGER Tip-over hazard. Operating the machine outside of the operating envelope while in Bypass mode will result in death or serious injury if proper operating procedures and safety precautions are not followed. Do not use this mode if you are not trained and familiar with the operating envelope of the machine.

Note: Before using the Bypass mode, make sure you understand the fault code or issue affecting the operation of the machine to be sure the use of bypass is required.

The Bypass mode will allow the platform to be manually leveled when an out-of-level condition exists. In the event that the platform angle is greater than 10° from level, the boom angle and platform level functions are disabled. Use of the Bypass mode will allow the platform to be manually adjusted to within the normal operating envelope, ±4.5°. Only auxiliary power can be used to correct an out of level platform fault.

- 1 Turn the engine off.
- 2 Turn the main key switch to ground controls. Remove the key from the main key switch and insert the key into the bypass/recovery key switch.

Note: The main key switch must remain in the ground control position.

- 3 Turn the bypass/recovery key switch to the bypass position.

- 4 Using auxiliary power, operate the ground control buttons to level the platform.

Note: Only the auxiliary power unit can be used to correct an out of level platform fault.

- 5 Turn the bypass/recovery key switch to the run position.

- 6 Remove the key from the bypass/recovery key switch and insert the key into the main key switch.

Note: If the Bypass function has been used, there may be faults with the machine. Check the LCD screen on the ground control box for machine faults, then contact trained service personnel.

Ground Controls

How to Use the Recovery Mode

Recovery is only to be used as a last attempt to lower the platform when the operator in the platform is unable to do so, system failure or in emergency situations.

⚠ WARNING Bodily injury hazard. When using recovery mode, the platform may not fully lower to the ground when the recovery mode is completed. Failure to use only suitable equipment and/or practices to allow the operator to safely exit the platform could result in death or serious injury.

⚠ WARNING Bodily injury hazard. Platform leveling is not active when using recovery mode. The platform could reach high out-of-level conditions when using this mode. The operator will need to secure themselves to the platform to prevent falling injury.

The Recovery mode allows the platform to be lowered in the event the operator in the platform is unable to lower the platform using the platform controls, system failure or emergency situations. The recovery sequence will automatically retract the primary boom, retract the secondary boom and then lower the primary boom using the auxiliary power unit to allow the operator at the platform controls to exit the platform.

Note: This procedure is for machines using software version 1.11 and later. For machines using software version 1.01, contact Genie Product Support.

- 1 Turn the main key switch to ground controls. Remove the key from the main key switch and insert the key into the bypass/recovery key switch.

Note: If this procedure is performed with the main key switch in the off position an active latched safety fault will be set and will have to be cleared.

- 2 Turn and hold the bypass/recovery key switch to the recovery position. The switch must be held in the recovery position.
 - ⊙ Result: The auxiliary power unit will turn on and the boom will begin the following recovery sequence.
 - The primary boom will retract.
 - The secondary boom will retract.
 - The primary boom will lower.

Note: The key switch must be held in the recovery position until the recovery sequence is complete or until the operator in the platform can safely exit the platform.

Note: If any boom safety limit switches are faulty, the boom will only retract and not lower and the operator will need to be recovered from that point.

Note: If the event the platform becomes out of level $\pm 15^\circ$, all functions using auxiliary power will be disabled, PLATFORM LEVEL > 15 DEGREES will be displayed on the ground control LCD screen, and the operator will have to be recovered using the Recovery Mode.

Note: If the Recovery function has been used, this may indicate there may be faults with the machine. Tag and remove the machine from service until the fault has been corrected by trained personnel.

Ground Controls

6-2 Circuit Boards

The ground control box contains a replaceable membrane decal with touch sensitive buttons for various machine functions. The ground control box also contains two printed circuit boards:

The LCD (Liquid Crystal Display) circuit board is mounted to the inside of the control box lid which controls the LCD display screen.

The ECM circuit board is the main circuit board for the machine. All operating parameters and configuration of options for the machine are stored in the ECM memory.

Note: When the ECM circuit board is replaced, the machine will need to be fully calibrated. Refer to Repair Procedure, *How to Fully Calibrate the Machine*.

How to Remove the LCD Display Screen Circuit Board

- 1 Push in the red Emergency Stop button to the off position at both the ground and platform controls.
- 2 Remove the ground control box lid fasteners.
- 3 Open the ground control box.

⚠ WARNING Electrocutation/burn hazard. Contact with electrically charged circuits could result in death or serious injury. Remove all rings, watches and other jewelry.

NOTICE Component damage hazard. Electrostatic discharge (ESD) can damage printed circuit board components. Maintain firm contact with a metal part of the machine that is grounded at all times when handling printed circuit boards OR use a grounded wrist strap.

- 4 Carefully disconnect the LCD circuit board ribbon cable from the ECM circuit board.
- 5 Remove the LCD display circuit board retaining fasteners.
- 6 Carefully remove the LCD display circuit board from the ground control box lid.

Ground Controls

How to Remove the ALC-1000 Circuit Board

Note: If the ALC-1000 circuit board (TCON) has been replaced, the entire machine must be calibrated in a specific order. Refer to Repair Procedure, *Full Machine Calibration*.

- 1 Push in the red Emergency Stop button to the off position at both the ground and platform controls.
- 2 Remove the ground control box lid fasteners.
- 3 Open the ground control box.
- 4 Tag and disconnect the harnesses from the ground control box.
- 5 Remove the control cable receptacle retaining fasteners from the side of the control box.
- 6 Attach a grounded wrist strap to the ground screw inside the control box.
- 7 Tag and carefully disconnect the wire connectors from the circuit board.
- 8 Carefully disconnect the LCD circuit board ribbon cable from the ECM circuit board.
- 9 Carefully disconnect the two ribbon cables from the membrane decal at the ECM circuit board.
- 10 Remove the circuit board mounting fasteners.
- 11 Carefully remove the circuit board from the control box.

⚠ WARNING

Electrocution/burn hazard. Contact with electrically charged circuits could result in death or serious injury. Remove all rings, watches and other jewelry.

NOTICE

Component damage hazard. Electrostatic discharge (ESD) can damage printed circuit board components. Maintain firm contact with a metal part of the machine that is grounded at all times when handling printed circuit boards OR use a grounded wrist strap.

Ground Controls

6-3

Membrane Decal

The membrane decal is a special decal that consists of a decal with an electronic membrane on the backside. The membrane contains touch sensitive areas that, when pushed, activate the machine functions. The membrane contains touch sensitive areas that activate the machine functions.

How to Replace the Membrane Decal

- 1 Turn the key switch to the off position and push in the red Emergency Stop button to the off position at both the ground and platform controls.
 - 2 Remove the ground control box lid fasteners.
 - 3 Open the ground control box.
 - 4 Carefully disconnect the two ribbon cables from the membrane decal at the ECM circuit board.
- ⚠ WARNING** Electrocutation/burn hazard. Contact with electrically charged circuits could result in death or serious injury. Remove all rings, watches and other jewelry.
- NOTICE** Component damage hazard. Electrostatic discharge (ESD) can damage printed circuit board components. Maintain firm contact with a metal part of the machine that is grounded at all times when handling printed circuit boards OR use a grounded wrist strap.
- 5 Carefully remove the membrane decal from the control box lid while guiding the ribbon cables out of the control box lid.
 - 6 Remove any decal adhesive from the control box lid with a mild solvent.
- Note: Do not allow any solvent to come in contact with the LCD display screen.
- 7 Install the new membrane decal while guiding the ribbon cables through the control box lid.
 - 8 Connect the ribbon cables to the ECM circuit board.
 - 9 Close the control box lid and install the retaining fasteners.

Ground Controls

6-4 Full Machine Calibration

Full machine calibration must be completed in the proper sequence when the ALC-1000 circuit board (TCON) in the ground control box has been replaced or the turntable level sensor (SCON) has been replaced.

How to Fully Calibrate the Machine

Calibration procedures shall only be completed by qualified technicians that have Genie factory service training.

⚠ WARNING Tip-over hazard. Failure to calibrate the machine in the proper sequence could cause the machine to tip over resulting in death or serious injury.

Note: A digital level will be required to perform this procedure.

Note: A kit is available through Genie Product Support (Genie part number 58351). This kit includes a digital level with a magnetic base and cable harnesses.

Note: Use the following chart to identify the description of each LCD screen control button used in this procedure.



Plus



Minus



Previous



Enter

Note: Start this procedure with the booms in the fully stowed position and the axle retracted.

Full machine calibration must be completed in the following sequence:

- Select engine configuration. Refer to Repair Section, Display Module. *Unit of Measure and Language.*
- Joysticks. Refer to Repair Procedure, *How to Calibrate a Joystick.*
- Turntable level sensor. Refer to Repair Procedure, *How to Calibrate the Turntable Level Sensor.*
- Platform level sensor. Refer to Repair Procedure, *How to Calibrate the Platform Level Sensor.*
- Axle angle sensors. Refer to Repair Procedure, *How to Calibrate the Axle Angle Sensors.*
- Steer sensors. Refer to Repair Procedure, *How to Calibrate All Steer Sensors.*
- Secondary boom angle sensor. Refer to Repair Procedure, *How to Calibrate the Secondary Boom Angle Sensor.*
- Primary boom angle sensor. Refer to Repair Procedure, *How to Calibrate the Primary Boom Angle Sensor.*
- Jib boom bellcrank angle sensor. Refer to Repair Procedure, *How to Calibrate the Jib Boom Bellcrank Sensor.*
- Select option configuration. Refer to Repair Section, Display Module. *Options.*

Display Module

This table lists the various screens and menu options of the operating software. Some display menus are for informational purpose only, while others can be used to change the machine operating parameters.

⚠ WARNING Tip-over hazard. Calibration and parameter settings must be completed by a person trained and qualified on the repair of this machine. Failure to properly calibrate or set parameters could cause the machine to tip over resulting in death or serious injury.

Note: The key switch must be in the off position before entering the programming mode.

Note: Use the following chart to identify the description of each LCD screen control button used in this procedure.



Plus



Minus



Previous



Enter

Activation of the **enter** or **previous** buttons scrolls through the screens. To change parameter values or select a setting, use the **plus** button (to increase or scroll forward) and the **minus** button (to decrease or scroll backwards). Then press the **enter** button to save the new value to memory. An audible beep will indicate a save to memory. Use the **enter** and **previous** buttons to scroll to the EXIT menu. Use the **plus** button to change to YES and use the **enter** button to exit.

Screen or Menu	Procedure	Description	Range or Selection
Operator	Default	Hourmeter (on power up) Engine speed Engine oil pressure PSI (English) Engine oil pressure kPa (metric) Engine temperature °F (English) Engine temperature °C (metric) Primary boom angle to gravity Turntable level sensor X° direction Turntable level sensor Y° direction Platform level sensor degree Battery volts	engine temp will not display until temp is >100°F engine temp will not display until temp is >38°C

Display Module

Screen or Menu	Procedure	Description	Range or Selection
Machine Status	With key switch on, press the (plus)(minus) buttons at the same time.	Hydraulic pressure PSI (English) Hydraulic pressure kPa (metric) Primary boom to secondary boom angle Primary boom length Secondary boom angle* Secondary boom length Jib bellcrank angle DPF Regeneration Mode (Auto / Force / Inhibit)	0-4500 PSI 0-31000 kPa +22° to +136° =0', >0', >22 -3.5° to 76° =0FT, >0 FT -10° to +10° *(referenced to chassis tilt angle)
Unit of Measure and Language	With key switch OFF, press and hold the enter button and turn key switch to on position. Release the enter button and press (plus)(minus)(minus)(plus) . Overload Recovery (software V3.07 and later)	Metric/English (measurement units) Set engine Clear Overload Recovery	English, German, French, Spanish, Portuguese, Italian, Dutch, and Swedish. Deutz TD2011L04i (DL04i) Perkins 1104D-44T (P1104) YES/NO A passcode is required to clear the message
Default Reset Software version 3.11 or lower and software version 4.01	With key switch OFF, press and hold the enter button and turn key switch to on position. Release the enter button and press (minus)(minus)(previous)(previous)	Delete drive functions Delete boom function speed Delete lift function ramps Delete all (Contact Genie Product Support before using this option) Delete Faults	Delete faults will reset active latching faults. Delete faults will not clear fault history.

Display Module

Screen or Menu	Procedure	Description	Range or Selection
Default Reset Software version 3.12 and software version 4.02 or higher	With key switch OFF, press and hold the enter button and turn key switch to on position. Release the enter button and press (minus)(minus)(previous)(previous)	Delete drive functions Delete boom function speed Delete lift function ramps Delete all (Contact Genie Product Support before using this option)	
Clear Faults Software version 3.12 and software version 4.02 or higher	With key switch OFF, press and hold the enter button and turn key switch to on position. Release the enter button and press (minus)(previous)(previous)(minus)	Clear all safety switch faults	Reset faults will reset active latching faults, will not clear fault history
Drive Functions	With key switch OFF, press and hold the enter button and turn key switch to on position. Release the enter button and press (plus)(plus)(enter)(enter) .	Forward extended drive speed % Forward not stowed drive speed % Forward low drive speed % Forward high drive speed % Reverse extended drive speed % Reverse not stowed drive speed % Reverse low drive speed % Reverse high drive speed % Drive acceleration % Drive deceleration % Speed limit on steer angle	120% (max) 100% (default) 50% (min) 120% (max) 100% (default) 50% (min) 120% (max) 100% (default) 50% (min) 120% (max) 100% (default) 50% (min) 120% (max) 100% (default) 50% (min) 120% (max) 100% (default) 50% (min) 120% (max) 100% (default) 50% (min) 120% (max) 100% (default) 50% (min) 125% (max) 100% (default) 25% (min) 125% (max) 100% (default) 25% (min) 100% (max) 50% (default) 0%

Display Module

Screen or Menu	Procedure	Description	Range or Selection
Boom Function Speeds	With key switch OFF, press and hold the enter button and turn key switch to on position. Release the enter button and press (plus)(plus)(minus)(minus)	Primary boom up speed stowed Primary boom up speed not stowed Primary boom down speed stowed Primary boom down speed not stowed Primary boom extend speed Primary boom retract speed Secondary boom up speed stowed Secondary boom up speed not stowed Secondary boom down speed stowed Secondary boom down speed not stowed Secondary boom extend speed Secondary boom retract speed Turntable rotate speed retracted Turntable rotate speed not retracted Turntable rotate speed extended Jib up speed retracted Jib up speed not retracted Jib down speed retracted Jib down speed not retracted	120% max, 50% min, 100% (default)



Display Module

Screen or Menu	Procedure	Description	Range or Selection
Lift Functions Ramps	With key switch OFF, press and hold the enter button and turn key switch to on position. Release the enter button and press (plus)(plus)(previous)(previous) .	Primary boom up/down ramp acceleration %	150% max and 50% min 100% (default), 5% increment
		Primary boom up/down ramp deceleration %	
		Primary boom extend/retract ramp acceleration %	
		Primary boom extend/retract ramp deceleration %	
		Secondary boom up/down ramp acceleration %	
		Secondary boom up/down ramp deceleration %	
		Secondary boom extend/retract ramp acceleration %	
		Secondary boom extend/retract ramp deceleration %	
		Turntable rotate ramp acceleration %	
		Turntable rotate ramp deceleration %	
Jib boom up/down ramp acceleration %	120% max and 50% min, 100% (default), 5% incr		
Jib boom up/down ramp deceleration %			

Display Module

Screen or Menu	Procedure	Description	Range or Selection
<p>Valve Calibration</p>	<p>With key switch OFF, press and hold the enter button and turn key switch to on position. Release the enter button and press (minus)(minus)(enter)(enter).</p>	<p>Delete drive valve calibration</p> <p>Delete primary boom up/down valve calibration</p> <p>Delete primary boom extend/retract valve calibration</p> <p>Delete secondary boom up/down and extend/retract valve calibration</p> <p>Delete turntable rotate valve calibration</p> <p>Allow primary boom up/down speed calibration</p> <p>Allow primary boom extend/retract speed calibration</p> <p>Allow secondary boom up/down speed calibration</p> <p>Allow turntable rotate speed calibration</p> <p>Delete drive joystick calibration</p> <p>Delete primary boom up/down joystick calibration</p> <p>Delete primary boom extend/retract joystick calibration</p> <p>Delete secondary boom joystick calibration</p> <p>Delete turntable rotate joystick calibration</p> <p>Delete steer joystick calibration</p> <p>Delete jib up/down joystick calibration</p>	<p>YES/NO</p>



Display Module

Screen or Menu	Procedure	Description	Range or Selection
Sensor Calibration (before software version 4.01)	With key switch OFF, press and hold the enter button and turn key switch to on position. Release the enter button and press (plus)(enter)(enter)(plus) .	Set unit X-axis to gravity Set unit Y-axis to gravity Set platform level to gravity (YES/NO) Platform level sensor millivolts/degree Delete axles angle sensors calibration? (YES/NO) YES: Axle angle fully retracted (YES/NO) YES: Axle angle fully extended (YES/NO) Delete all steer sensors calibrations? (YES/NO) Delete blue end blue side steer sensor (FL) calibration? (YES/NO) Delete yellow end blue side steer sensor (RL) calibration? (YES/NO) Delete blue end yellow side steer sensor (FR) calibration? (YES/NO) Delete yellow end yellow side steer sensor (RR) calibration? (YES/NO) Delete secondary boom angle sensor calibration? (YES/NO) secondary boom angle to gravity -3.5° secondary boom angle to gravity 20° secondary boom angle to gravity 35° secondary boom angle to gravity 50° secondary boom angle to gravity 65° secondary boom angle to gravity 76° Delete primary boom angle sensor calibration? (YES/NO) primary boom angle to gravity 0° primary boom angle to gravity -50° primary boom angle to gravity -20° primary boom angle to gravity 10° primary boom angle to gravity 40° primary boom angle to gravity 70° Delete level angle sensor calibration? (YES/NO) jib level calibration deg to gravity 60° jib level calibration deg to gravity 34° jib level calibration deg to gravity 8° jib level calibration deg to gravity -18° jib level calibration deg to gravity -44° jib level calibration deg to gravity -70°	Use +/- buttons to adjust



Display Module

Screen or Menu	Procedure	Description	Range or Selection
<p>Sensor Calibration (software version 4.01 and higher)</p>	<p>With key switch OFF, press and hold the enter button and turn key switch to on position. Release the enter button and press (plus)(enter)(enter)(plus).</p>	<p>Set unit X-axis to gravity Set unit Y-axis to gravity Set platform level to gravity (YES/NO) Platform level sensor millivolts/degree Delete axes angle sensors calibration? (YES/NO) YES: Axle angle fully retracted (YES/NO) YES: Axle angle fully extended (YES/NO) Delete all steer sensors calibrations? (YES/NO) Delete blue end blue side steer sensor (FL) calibration? (YES/NO) Delete yellow end blue side steer sensor (RL) calibration? (YES/NO) Delete blue end yellow side steer sensor (FR) calibration? (YES/NO) Delete yellow end yellow side steer sensor (RR) calibration? (YES/NO) Delete secondary boom angle sensor calibration? (YES/NO) Secondary boom fully lowered? (YES/NO) Secondary boom fully raised? (YES/NO) Delete primary boom angle sensor calibration? (YES/NO) Primary boom fully lowered? (YES/NO)° Primary boom fully raised? (YES/NO)° Delete jib level angle sensor calibration? (YES/NO) Jib level cylinder fully extended? (YES/NO) Jib level cylinder fully retracted? (YES/NO)</p>	<p>Use +/- buttons to adjust</p>



Hydraulic Pumps

7-1 Function Pump

The function pump is a pressure compensated, variable displacement piston pump. Any internal service to the pump should be performed at an authorized Sauer-Danfoss service center. Contact Genie Product Support to locate your local authorized service center.

How to Remove the Function Pump

Note: When removing a hose assembly or fitting, the O-ring (if equipped) on the fitting and/or hose end must be replaced. All connections must be torqued to specification during installation. Refer to Specifications, *Hydraulic Hose and Fitting Torque Specifications*.

- 1 Locate the two hydraulic tank valves at the hydraulic tank. Close the valves.

NOTICE

Component damage hazard. The engine must not be started with the hydraulic tank shut-off valves in the closed position or component damage will occur. If the tank valves are closed, remove the key from the key switch and tag the machine to inform personnel of the condition.

- 2 Tag, disconnect and plug the function pump hydraulic hoses. Cap the fittings on the pump.

WARNING

Bodily injury hazard. Spraying hydraulic oil can penetrate and burn skin. Loosen hydraulic connections very slowly to allow the oil pressure to dissipate gradually. Do not allow oil to squirt or spray.

- 3 Support the pump with a suitable lifting device.
- 4 Remove the two pump mounting fasteners. Carefully remove the pump.

NOTICE

Component damage hazard. Be sure to open the two hydraulic tank valves and prime the pump after installing the pump.

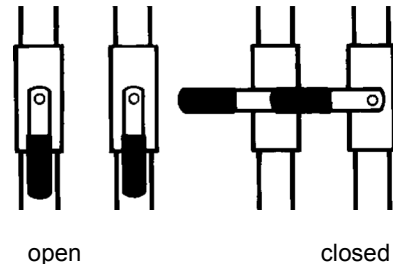

Hydraulic Pumps

How to Prime the Function Pump

Note: When removing a hose assembly or fitting, the O-ring (if equipped) on the fitting and/or hose end must be replaced. All connections must be torqued to specification during installation. Refer to Specifications, *Hydraulic Hose and Fitting Torque Specifications*.

- 1 Remove the case drain hydraulic hose from the top of the function pump.

Note: The case drain hose is the smaller of the two hoses on top of the function pump and closest to the drive pump.

- 2 Locate and open the hydraulic tank shut-off valve at the hydraulic tank that supplies hydraulic oil to the function pump. Do not open the valve for the drive pump.
- 3 When hydraulic fluid begins to come out of the case drain port of the function pump, install the function pump case drain hose.
- 4 Clean up any oil that may have spilled. Properly discard the used oil.
- 5 Start the engine from the ground controls.
- 6 Check for hydraulic leaks.

How to Adjust the Function Pump Standby Pressure

- 1 Connect a 0 to 5000 psi / 0 to 350 bar pressure gauge to the test port on the function manifold
- 2 Start the engine from the ground controls and allow the engine to run at low idle.
- 3 Observe the pressure reading on the pressure gauge.
 - ⊙ Result: The gauge should show 250 psi / 17 bar.
 - ⊗ Result: If the gauge does not show 250 psi / 17 bar, proceed with step 4 to adjust the function pump standby pressure.
- 4 Loosen the set screw for the standby pressure adjustment screw.

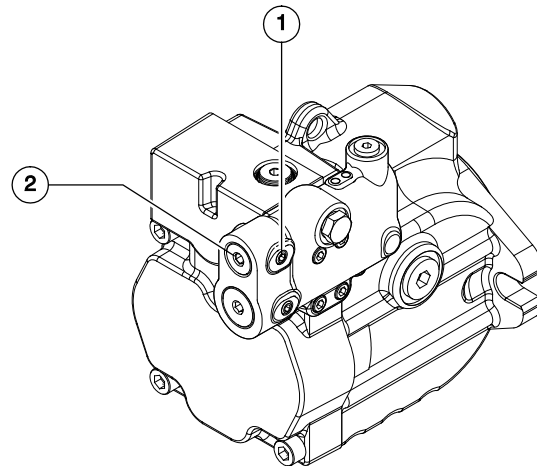

- 1 standby pressure set screw
- 2 standby pressure adjustment screw

Hydraulic Pumps

- 5 Adjust the function pump standby pressure. Turn the adjustment screw clockwise to increase the pressure or counterclockwise to decrease the pressure. Tighten the set screw.
- 6 Turn the engine off and remove the pressure gauge.

How to Adjust the Function Pump Pressure Compensator

Note: Two people will be required to perform this procedure.

- 1 Confirm the system relief pressure is set to specification. Refer to Repair Procedure, *Valve Adjustments - Function Manifold*.
- 2 Connect a 0 to 5000 psi / 0 to 350 bar pressure gauge to the test port on the function manifold
- 3 Start the engine from the ground controls and change the rpm to high idle.
- 4 Push and hold the high speed function enable button (rabbit symbol). Do not activate any boom functions.
- 5 Observe the pressure reading on the pressure gauge.
 - ⦿ Result: The gauge should show 2900 psi / 200 bar.
 - ⊗ Result: If the gauge does not show 2900 psi / 200 bar, proceed to step 6 to adjust the function pump pressure compensator.

- 6 Loosen the set screw for the pressure compensator adjustment screw.

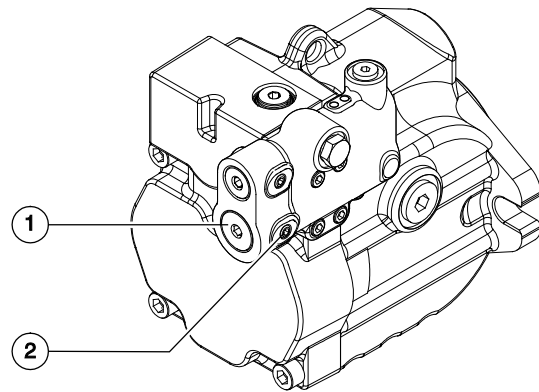

- 1 pressure compensator set screw
- 2 pressure compensator adjustment screw

- 7 Adjust the pressure compensator pressure. Turn the adjustment screw clockwise to increase the pressure or counterclockwise to decrease the pressure. Tighten the set screw.

NOTICE

Component damage hazard. Do not adjust the pressure compensator higher than specified.

- 8 Turn the engine off and remove the pressure gauge.

Hydraulic Pumps

7-2 Drive Pump

The drive pump is a bi-directional variable displacement piston pump. The pump output is controlled by the electronic displacement controller (EDC), located on the pump. The only adjustment that can be made to the pump is the neutral or null adjustment. Any internal service to the pump should be performed at an authorized Sauer-Danfoss service center. Contact Genie Product Support to locate your local authorized service center.

How to Remove the Drive Pump

NOTICE Component damage hazard. The work area and surfaces where this procedure will be performed must be clean and free of debris that could get into the hydraulic system and cause severe component damage. Dealer service is recommended.

Note: When removing a hose assembly or fitting, the O-ring (if equipped) on the fitting and/or hose end must be replaced. All connections must be torqued to specification during installation. Refer to Specifications, *Hydraulic Hose and Fitting Torque Specifications*.

- 1 Disconnect the wiring plug at the electronic displacement controller (EDC), located on the drive pump.

- 2 Locate the two hydraulic tank valves at the hydraulic tank. Close the valves.

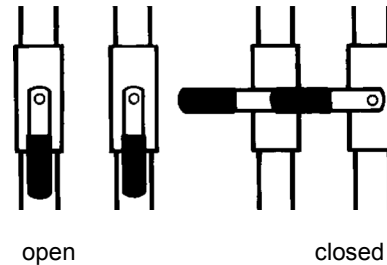

NOTICE Component damage hazard. The engine must not be started with the hydraulic tank shut-off valves in the closed position or component damage will occur. If the tank valves are closed, remove the key from the key switch and tag the machine to inform personnel of the condition.

- 3 Tag, disconnect and plug the hydraulic hoses from the drive and function pumps. Cap the fittings on the pumps.

WARNING Bodily injury hazard. Spraying hydraulic oil can penetrate and burn skin. Loosen hydraulic connections very slowly to allow the oil pressure to dissipate gradually. Do not allow oil to squirt or spray.

- 4 Support the pumps with a suitable lifting device and remove the two drive pump mounting fasteners.

Hydraulic Pumps

- 5 Carefully pull the drive pump out until the pump coupler separates from the flex plate.
- 6 Remove the drive pump from the machine.

NOTICE Component damage hazard. The pump(s) may become unbalanced and fall if not properly supported.

NOTICE Component damage hazard. The engine must not be started with the hydraulic tank shut-off valves in the closed position or component damage will occur. If the tank valves are closed, remove the key from the key switch and tag the machine to inform personnel of the condition.

How to Prime the Drive Pump

NOTICE Component damage hazard. Be sure to open the two hydraulic tank valves before performing this procedure.

- 1 Connect a 0 to 600 psi / 0 to 50 bar pressure gauge to either the "A" or "B" test port on the drive pump.
- 2 **Perkins models:** Disconnect the engine wiring harness from the fuel shutoff solenoid at the injector pump.
Deutz models: Hold the manual fuel shutoff valve clockwise to the closed position.
- 3 Have another person crank the engine with the starter motor for 15 seconds, wait 15 seconds, then crank the engine an additional 15 seconds or until the pressure reaches approximately 250 psi / 17 bar.
- 4 **Perkins models:** Connect the engine wiring harness to the fuel solenoid.
Deutz models: Release the manual fuel shutoff valve.
- 5 Start the engine from the ground controls.
- 6 Check for hydraulic leaks.

Manifolds

8-1

Function Manifold - View 1 (before serial number 440)

The function manifold is mounted to the turntable next to the ground controls.

Index No.	Description	Schematic Item	Function	Torque
1	Check valve	W	Prevents the draining of hydraulic oil from the jib manifold and platform manifold	30-35 ft-lbs / 41-47 Nm
2	Solenoid Valve, 2 position 3 way	C	Primary boom up	30-35 ft-lbs / 41-47 Nm
3	Solenoid Valve, 2 position 3 way	G	Primary boom retract	30-35 ft-lbs / 41-47 Nm
4	Solenoid Valve, 2 position 3 way	J	Secondary boom extend	50-55 ft-lbs / 68-75 Nm
5	Solenoid Valve, 2 position 3 way	H	Secondary boom up	50-55 ft-lbs / 68-75 Nm
6	Plug, 16 SAE		Port plug	130-140 ft-lbs / 176-190 Nm
7	Relief valve, 3100 psi / 214 bar	L	System relief	30-35 ft-lbs / 41-47 Nm
8	Solenoid Valve, 2 position 3 way	I	Secondary boom down	30-35 ft-lbs / 41-47 Nm
9	Solenoid Valve, 2 position 3 way	K	Secondary boom retract	30-35 ft-lbs / 41-47 Nm
10	Solenoid Valve, 2 position 3 way	F	Primary boom extend	30-35 ft-lbs / 41-47 Nm
11	Solenoid valve, 3 position 4 way	B	Turntable rotate left/right	30-35 ft-lbs / 41-47 Nm
12	Solenoid Valve, 2 position 3 way	D	Primary boom down	30-35 ft-lbs / 41-47 Nm

Manifolds

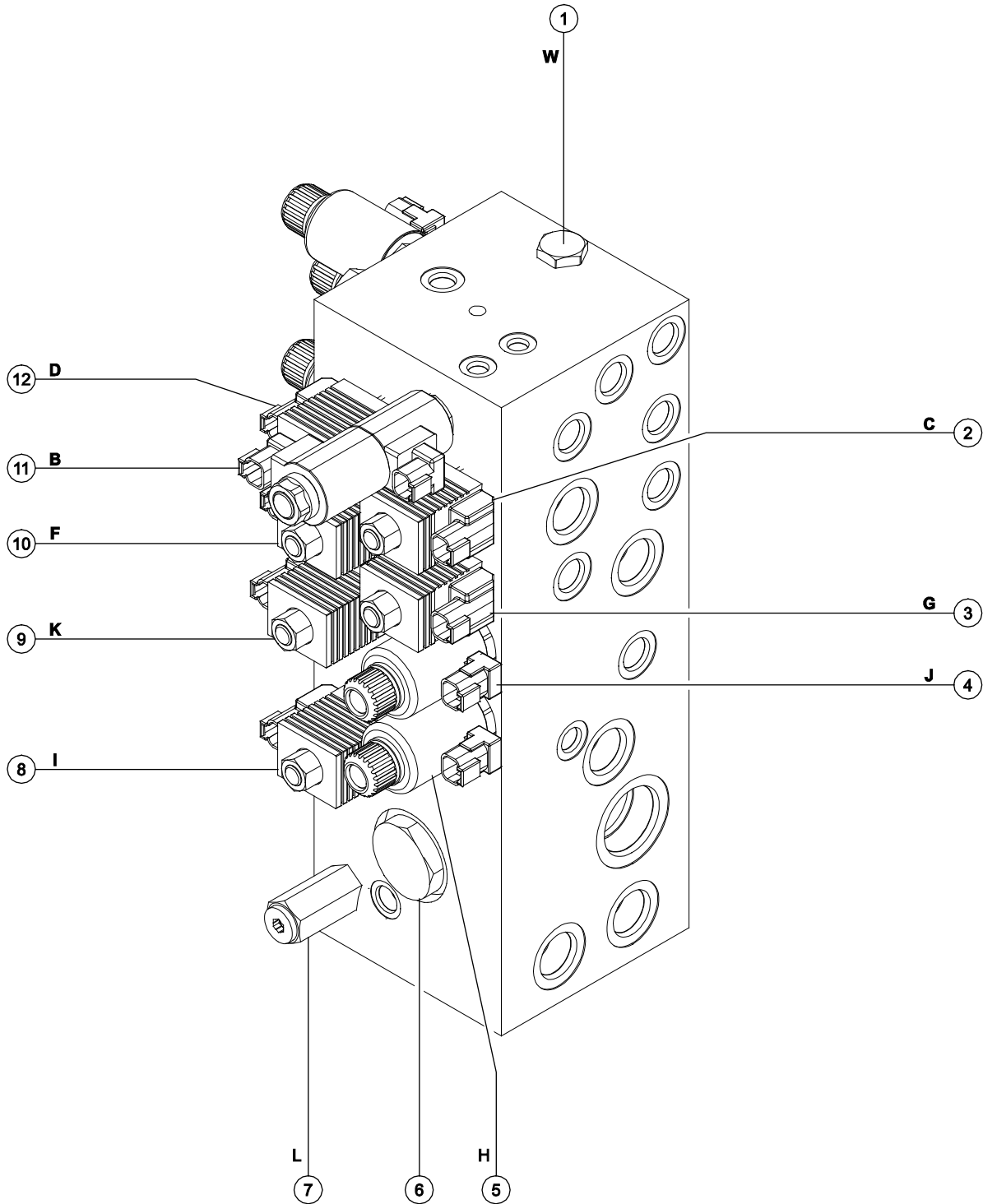

Manifolds

Function Manifold - View 2 (before serial number 440)

Index No.	Description	Schematic Item	Function	Torque
1	Check valve	DB	Prevents hydraulic pressure from flowing back into auxiliary pump #1	
2	Check valve	DC	Prevents hydraulic pressure from flowing back into auxiliary pump #2	
3	Differential sensing valve, 150 psi / 10.3 bar	M	Turntable rotate circuit, regulates pressure drop across turntable rotate proportional valve	30-35 ft-lbs / 41-47 Nm
4	Differential sensing valve, 150 psi / 10.3 bar	O	Primary boom up/down circuit, regulates pressure drop across primary boom up/down proportional valve	30-35 ft-lbs / 41-47 Nm
5	Relief valve, 2600 psi / 179 bar	E	Primary boom extend	20-25 ft-lbs / 27-34 Nm
6	Differential sensing valve, 150 psi / 10.3 bar	Q	Primary boom extend/retract circuit, regulates pressure drop across primary boom extend/retract proportional valve	30-35 ft-lbs / 41-47 Nm
7	Differential sensing valve, 150 psi / 10.3 bar	U	Secondary boom extend/retract circuit, regulates pressure drop across secondary boom extend/retract proportional valve	50-55 ft-lbs / 68-75 Nm
8	Differential sensing valve, 150 psi / 10.3 bar	S	Secondary boom up/down circuit, regulates pressure drop across secondary boom up/down proportional valve	50-55 ft-lbs / 68-75 Nm
9	Proportional solenoid valve	T	Secondary boom up/down circuit	50-55 ft-lbs / 68-75 Nm
10	Check valve	DD	Prevents hydraulic pressure from flowing back into the function pump	130-140 ft-lbs / 176-190 Nm
11	Proportional solenoid valve	V	Secondary boom extend/retract circuit	50-55 ft-lbs / 68-75 Nm
12	Proportional solenoid valve	R	Primary boom extend/retract circuit	50-55 ft-lbs / 68-75 Nm
13	Proportional solenoid valve	P	Primary boom up/down circuit	50-55 ft-lbs / 68-75 Nm
14	Proportional solenoid valve	N	Turntable rotate left/right circuit	50-55 ft-lbs / 68-75 Nm

Manifolds

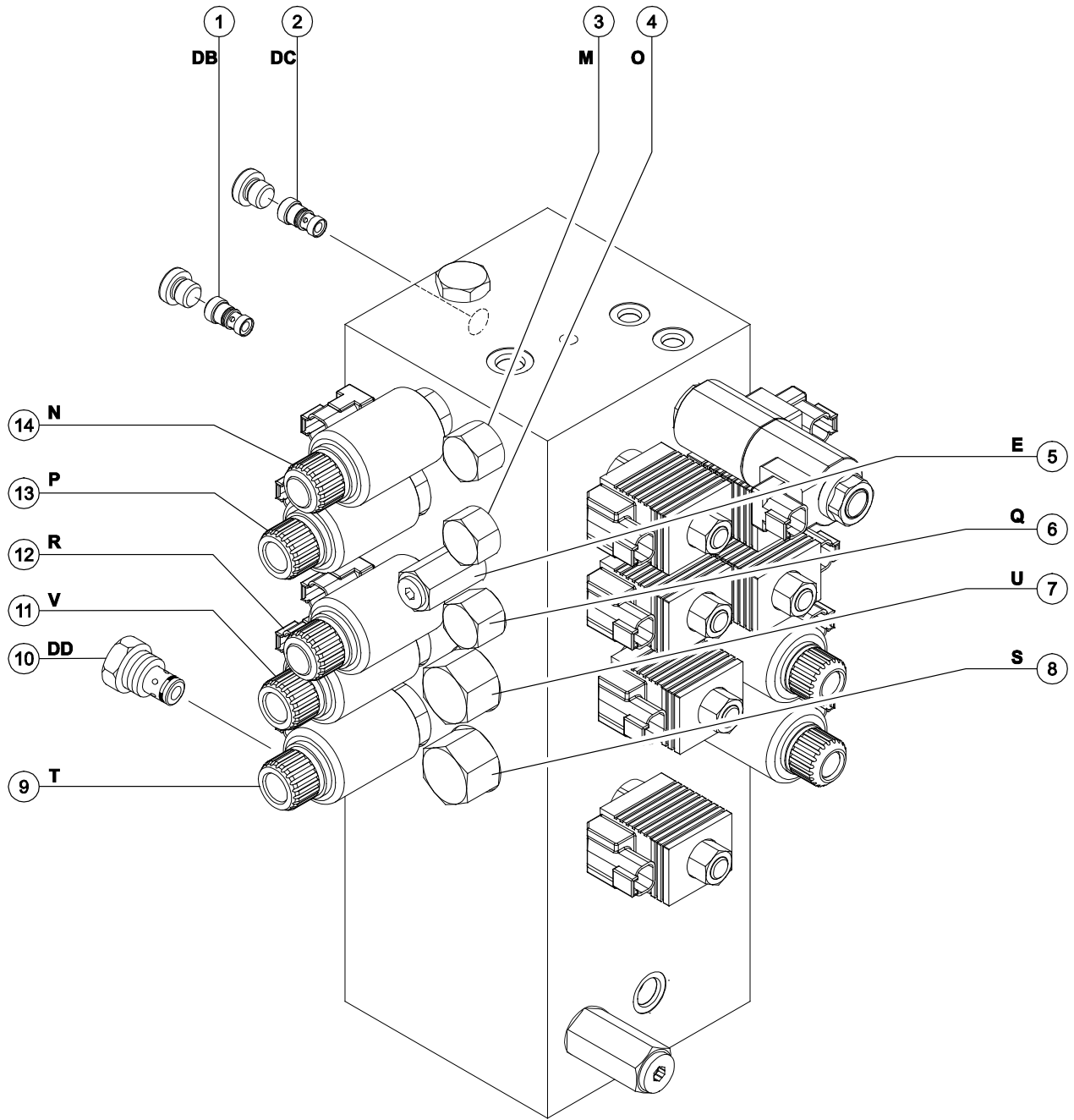

Manifolds

8-2

Function Manifold - View 1 (after serial number 439)

The function manifold is mounted to the turntable next to the ground controls.

Index No.	Description	Schematic Item	Function	Torque
1	Solenoid Valve, 2 position 3 way	D	Primary boom up/down	30-35 ft-lbs / 41-47 Nm
2	Solenoid Valve, 2 position 3 way	C	Primary boom up	30-35 ft-lbs / 41-47 Nm
3	Solenoid Valve, 2 position 3 way	G	Primary boom retract	30-35 ft-lbs / 41-47 Nm
4	Solenoid Valve, 2 position 3 way	F	Primary boom extend	30-35 ft-lbs / 41-47 Nm
5	Solenoid Valve, 2 position 3 way	K	Secondary boom retract	30-35 ft-lbs / 41-47 Nm
6	Solenoid Valve, 2 position 3 way	J	Secondary boom extend	30-35 ft-lbs / 41-47 Nm
7	Solenoid Valve, 2 position 3 way	I	Secondary boom down	30-35 ft-lbs / 41-47 Nm
8	Solenoid Valve, 2 position 3 way	H	Secondary boom up	30-35 ft-lbs / 41-47 Nm
9	Check valve	DF	Tank return circuit	130-140 ft-lbs / 176-190 Nm
10	Solenoid valve, 3 position 4 way	B	Turntable rotate left/right	30-35 ft-lbs / 41-47 Nm
11	Relief valve, 3100 psi / 214 bar	L	System relief	30-35 ft-lbs / 41-47 Nm
12	Differential sensing valve, 150 psi / 10.3 bar	S	Secondary boom up/down circuit, regulates pressure drop across secondary boom up/down proportional valve	50-55 ft-lbs / 68-75 Nm
13	Differential sensing valve, 150 psi / 10.3 bar	U	Secondary boom extend/retract circuit, regulates pressure drop across secondary boom extend/retract proportional valve	50-55 ft-lbs / 68-75 Nm
14	Differential sensing valve, 150 psi / 10.3 bar	Q	Primary boom extend/retract circuit, regulates pressure drop across primary boom extend/retract proportional valve	30-35 ft-lbs / 41-47 Nm

Manifolds

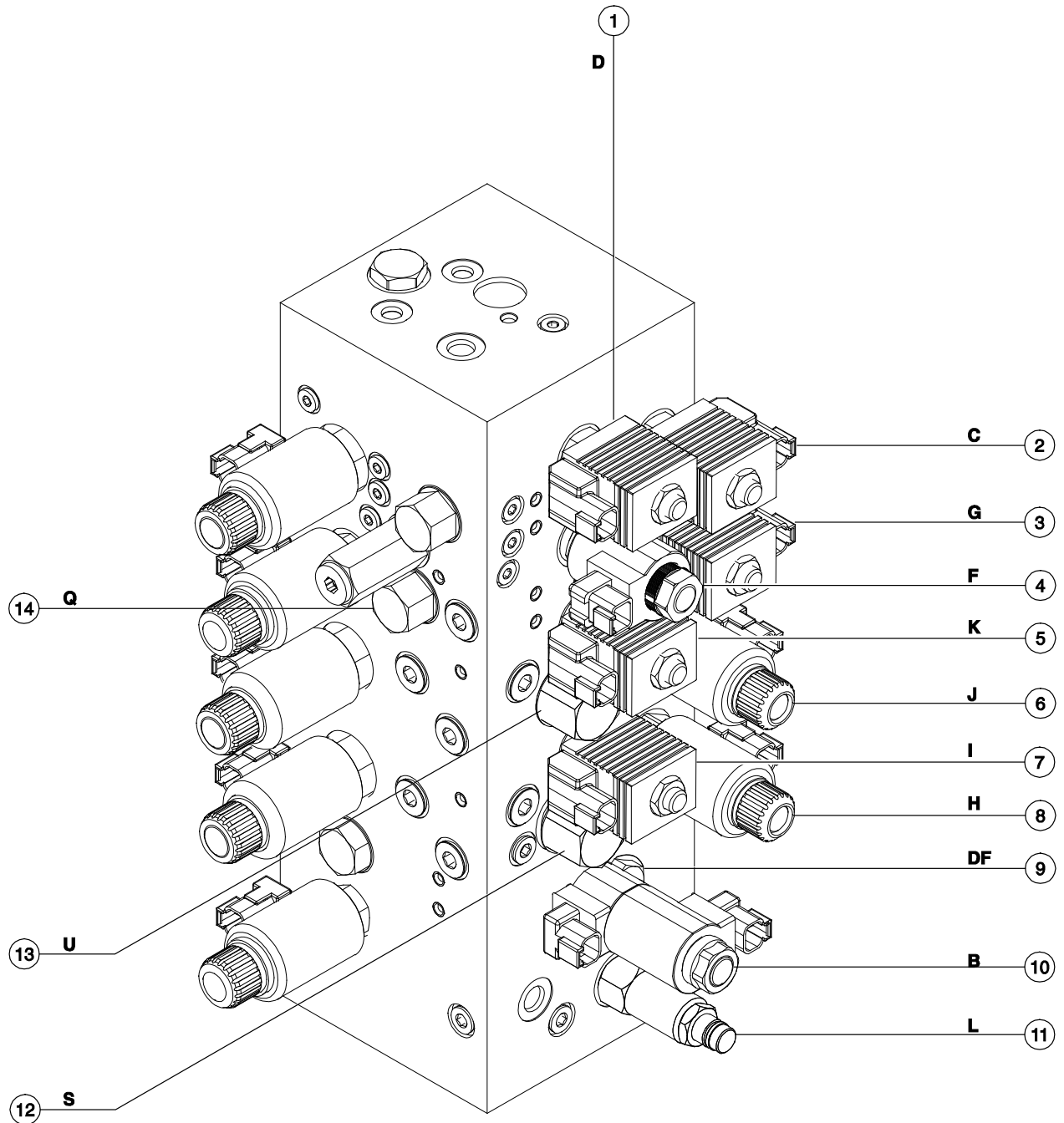

Manifolds

Function Manifold - View 2 (after serial number 439)

Index No.	Description	Schematic Item	Function	Torque
1	Check valve	DB	Prevents hydraulic pressure from flowing back into auxiliary pump #1	
2	Check valve	W	Prevents the draining of hydraulic oil from the jib manifold and platform manifold	30-35 ft-lbs / 41-47 Nm
3	Differential sensing valve, 150 psi / 10.3 bar	O	Primary boom up/down circuit, regulates pressure drop across primary boom up/down proportional valve	30-35 ft-lbs / 41-47 Nm
4	Relief valve, 2600 psi / 179 bar	E	Primary boom extend	20-25 ft-lbs / 27-34 Nm
5	Proportional solenoid valve	P	Primary boom up/down circuit	50-55 ft-lbs / 68-75 Nm
6	Proportional solenoid valve	R	Primary boom extend/retract circuit	50-55 ft-lbs / 68-75 Nm
7	Proportional solenoid valve	V	Secondary boom extend/retract circuit	50-55 ft-lbs / 68-75 Nm
8	Proportional solenoid valve	T	Secondary boom up/down circuit	50-55 ft-lbs / 68-75 Nm
9	Proportional solenoid valve	N	Turntable rotate left/right circuit	50-55 ft-lbs / 68-75 Nm
10	Differential sensing valve, 150 psi / 10.3 bar	M	Turntable rotate circuit, regulates pressure drop across turntable rotate proportional valve	30-35 ft-lbs / 41-47 Nm
11	Check valve	DD	Prevents hydraulic pressure from flowing back into the function pump	130-140 ft-lbs / 176-190 Nm
12	Check valve	DC	Prevents hydraulic pressure from flowing back into auxiliary pump #2	

Manifolds

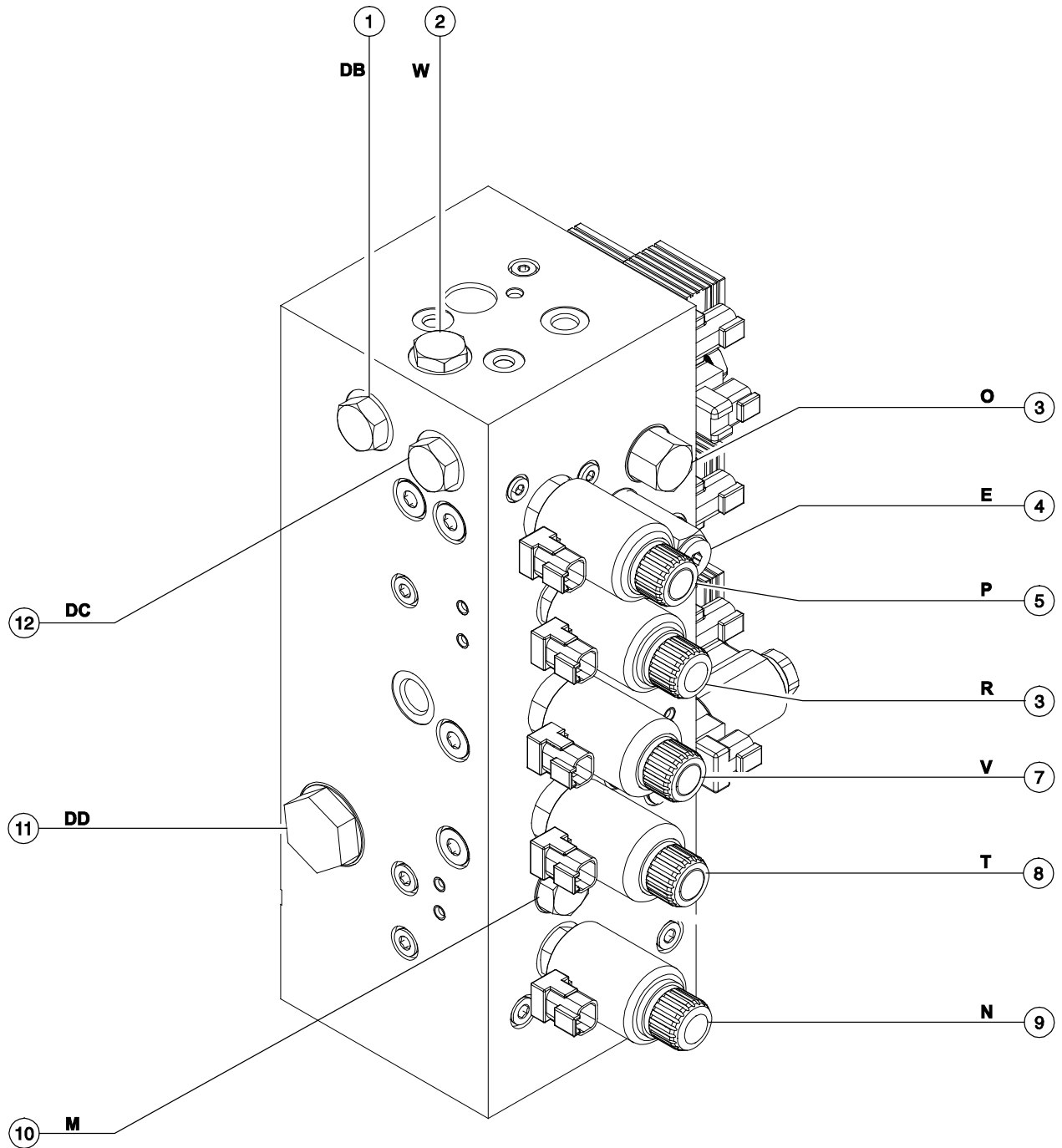

Manifolds

8-3 Valve Adjustments - Function Manifold

How to Adjust the System Relief Valve (before serial number 440)

Note: Perform this procedure with the boom in the stowed position.

Note: Auxiliary power will be used to perform this procedure. Do not start the engine.

Note: Refer to Function Manifold Component list to locate the system relief valve.

- 1 Hold the relief valve stem with a hex wrench and remove the cap.
- 2 Turn the internal hex socket counterclockwise several turns. Do not allow the relief valve to come apart. Install the relief cap.
- 3 Connect a 0 to 5000 psi / 0 to 350 bar pressure gauge to the test port on the function manifold

- 4 Simultaneously push and hold the auxiliary power button and the primary boom retract button with the primary boom fully retracted. Observe the pressure reading on the pressure gauge. Refer to Specifications, *Hydraulic Component Specification*.
- 5 Hold the relief valve stem with a hex wrench and remove the cap.
- 6 Adjust the internal hex socket. Turn it clockwise to increase the pressure. Install the relief cap.

⚠ WARNING

Tip-over hazard. Do not adjust the relief valve higher than specified.

- 7 Repeat step 4 to confirm relief valve pressure.
- 8 Remove the pressure gauge.

How to Adjust the System Relief Valve (after serial number 439)

Note: Perform this procedure with the boom in the stowed position.

Note: Auxiliary power will be used to perform this procedure. Do not start the engine.

Note: Refer to Function Manifold Component list to locate the system relief valve.

- 1 Hold the relief valve stem with a hex wrench and loosen the lock nut.
- 2 Turn the valve stem counterclockwise several turns. Do not allow the relief valve to come apart. Tighten the lock nut.
- 3 Connect a 0 to 5000 psi / 0 to 350 bar pressure gauge to the test port on the function manifold

Manifolds

- 4 Simultaneously push and hold the auxiliary power button and the primary boom retract button with the primary boom fully retracted. Observe the pressure reading on the pressure gauge. Refer to Specifications, *Hydraulic Component Specification*.
- 5 Hold the relief valve stem with a hex wrench and loosen the lock nut.
- 6 Adjust the valve stem. Turn it clockwise to increase the pressure. Tighten the lock nut.

⚠ WARNING Tip-over hazard. Do not adjust the relief valve higher than specified.

- 7 Repeat step 4 to confirm relief valve pressure.
- 8 Remove the pressure gauge.

How to Adjust the Primary Boom Extend Relief Valve

Note: Perform this procedure with the axles extended.

- 1 Remove the primary boom end cover from the pivot end of the boom.
- 2 Locate the primary boom extend limit switch on the side of the primary boom.
- 3 Follow the wiring from the switch to the pivot end of the primary boom. Locate and disconnect the wire connector for the primary boom extend limit switch.

Note: The correct wire connector will be a 2 pin connector with a yellow marker on the cable.

- 4 Start the engine and fully extend the primary boom. Turn the engine off.
- 5 Connect a 0 to 5000 psi / 0 to 350 bar pressure gauge to the ptst port on the function manifold.
- 6 Start the engine from the ground controls and press and release the rpm select button until the engine changes to high idle.

Manifolds

- 7 Simultaneously push and hold the function enable/high speed button and the primary boom extend button with the primary boom fully extended. Observe the pressure reading on the pressure gauge. Refer to Specifications, *Hydraulic Component Specifications*.
- 8 Turn the engine off. Use a wrench to hold the relief valve and remove the cap.
- 9 Adjust the internal hex socket. Turn it clockwise to increase the pressure or counterclockwise to decrease the pressure. Install the relief valve cap.

⚠ WARNING Tip-over hazard. Do not adjust the relief valve higher than specified.

- 10 Repeat step 7 to confirm relief valve pressure.
- 11 At the pivot end of the primary boom, connect the primary boom extend limit switch connector, that was disconnected in step 3.
- 12 Install the primary boom end cover.
- 13 Remove the pressure gauge.
- 14 Start the engine and fully retract the primary boom. Turn the engine off.

Manifolds

8-4 Platform Manifold

The platform manifold is mounted to the platform mounting weldment.

Index No.	Description	Schematic Item	Function	Torque
1	Solenoid valve, 3 position 4 way	AH	Platform rotate left/right	20-25 ft-lbs / 27-34 Nm
2	Proportional solenoid valve, 3 position 4 way	AI	Platform level up/down	20-25 ft-lbs / 27-34 Nm
3	Flow control valve, 0.2 gpm / 0.76 L/min	AG	Platform rotate left/right circuit	20-25 ft-lbs / 27-34 Nm

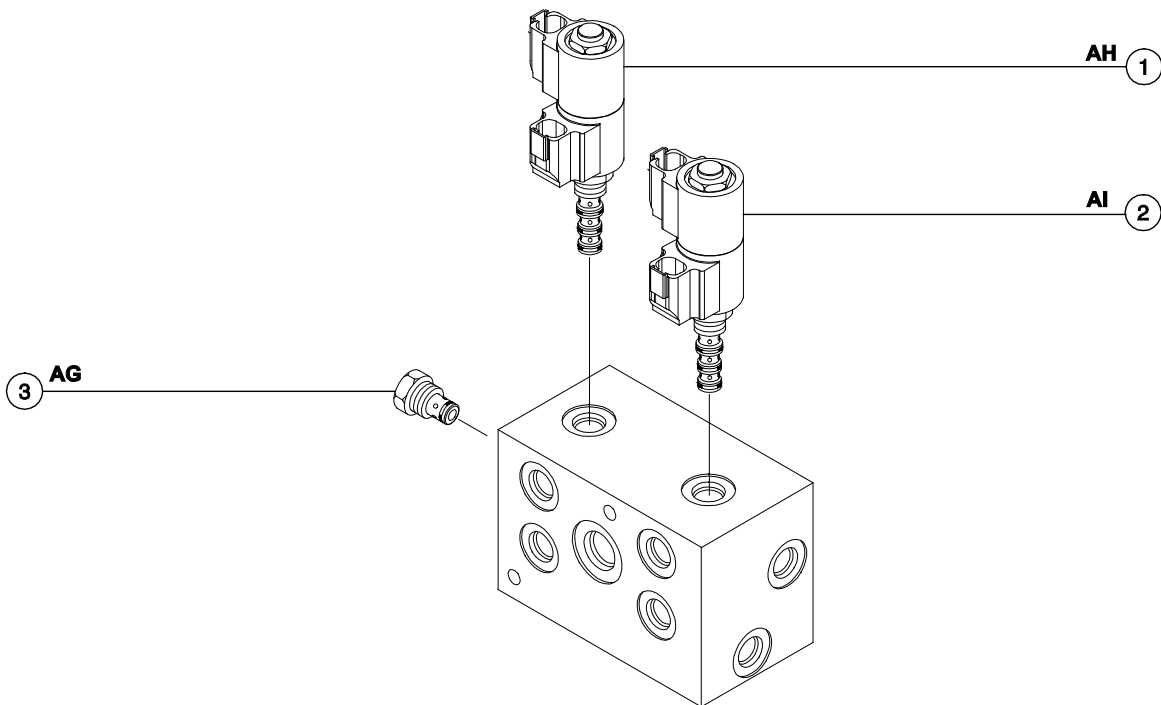

Manifolds

8-5

Jib Boom Manifold

The jib boom manifold is mounted inside the primary extension boom at the platform end.

Index No.	Description	Schematic Item	Function	Torque
1	Pressure compensator valve, 150 psi / 10.3 bar	X	Jib boom up/down circuit, regulates pressure drop across jib boom up/down proportional valve	30-35 ft-lbs / 41-47 Nm
2	Solenoid Valve, 2 position 3 way	AE	Jib boom retract	20-25 ft-lbs / 27-34 Nm
3	Solenoid Valve, 2 position 3 way	AD	Jib boom extend	20-25 ft-lbs / 27-34 Nm
4	Flow regulator valve, 2 gpm / 7.6 L/min	AC	Jib boom extend/retract circuit	20-25 ft-lbs / 27-34 Nm
5	Orifice, 0.040 inch / 1 mm	AB	Jib boom extend/retract circuit	
6	Check valve, 25 psi / 1.7 bar	AA	Holds oil in jib boom manifold	20-25 ft-lbs / 27-34 Nm
7	Shuttle valve	Z	Jib boom up/down circuit	10-12 ft-lbs / 14-16 Nm
8	Proportional solenoid valve, 3 position 4 way	Y	Jib boom up/down	20-25 ft-lbs / 27-34 Nm
9	Proportional solenoid valve, 3 position 4 way	AF	Jib boom bellcrank level up/down	20-25 ft-lbs / 27-34 Nm

Manifolds

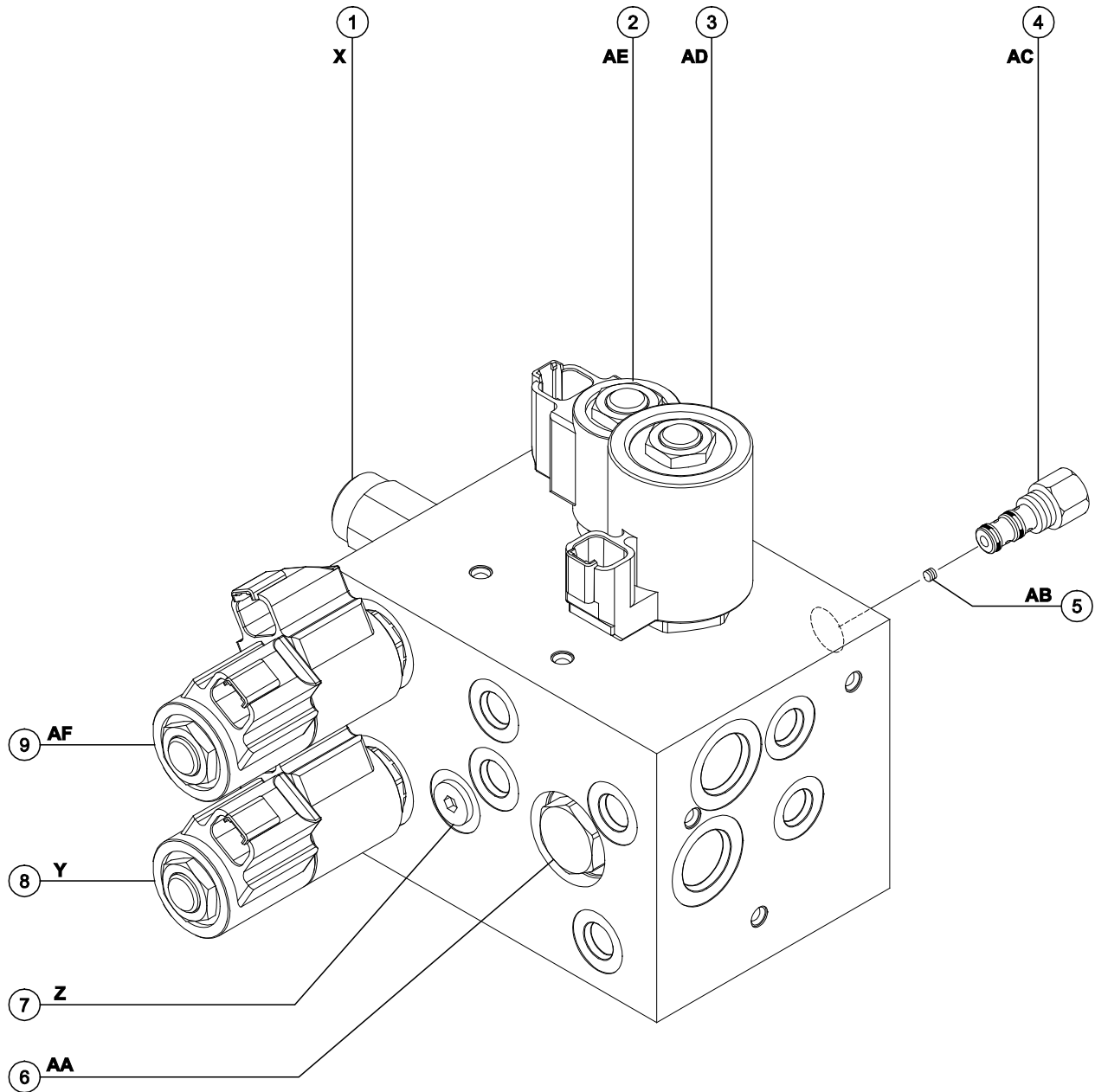

Manifolds

8-6 Flow Control Manifold

The flow control manifold is located at the platform next to the jib manifold.

Index No.	Description	Schematic Item	Function	Torque
1	Flow regulator valve, 0.5 gpm / 1.9 L/min	AC	Controls flow in the jib and platform manifold recirculation circuit	20 ft-lbs / 27 Nm

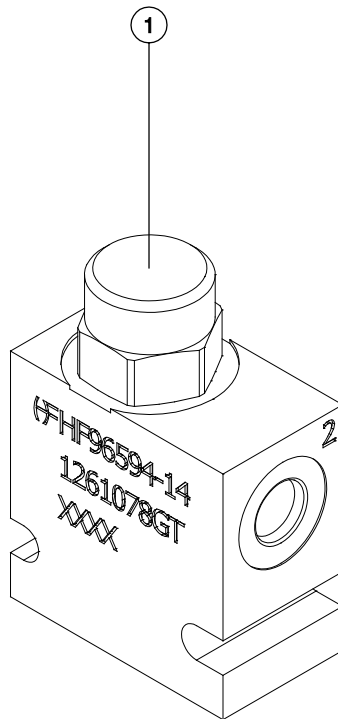

Manifolds

8-7 Function Enable Valve

The function enable valve is mounted behind the medium pressure filter.

Index No.	Description	Schematic Item	Function	Torque
1	Solenoid valve, 2 position 2 way	A	Enables lift pump to provide hydraulic pressure for all boom and steer/axle functions	20-25 ft-lbs / 27-34 Nm

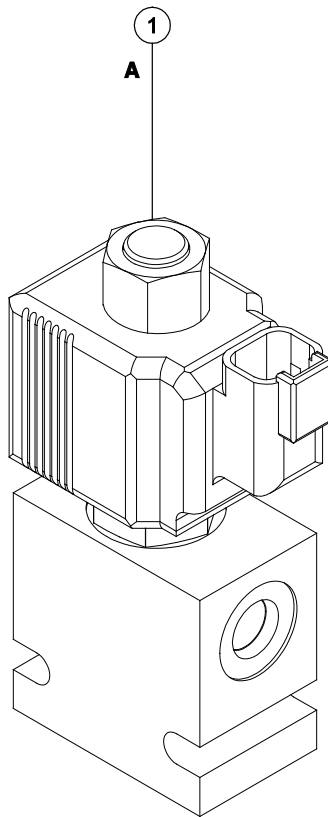

Manifolds

8-8 Turntable Rotation Manifold

The turntable rotation manifolds are mounted to the turntable rotation drive hub motors.

Index No.	Description	Schematic Item	Function	Torque
1	Counterbalance valve	CA	Turntable rotate right	25-30 ft-lbs / 34-41 Nm
2	Counterbalance valve	CB	Turntable rotate left	25-30 ft-lbs / 34-41 Nm
3	Shuttle valve. 2 position, 3 way	CC	Turntable rotation brake release	8-10 ft-lbs / 11-14 Nm
4	Orifice Plug, 0.030 inch / 0.76 mm	CD	Turntable rotation brake release	

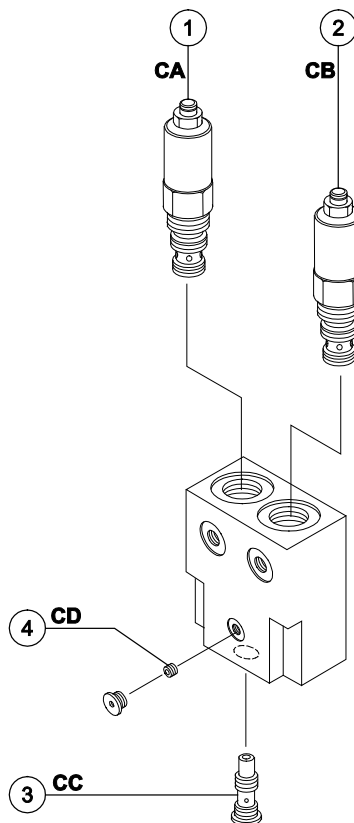

This page intentionally left blank.

Manifolds

8-9

Steer and Axle Manifold

The steer and axle manifold is mounted inside the manifold box at the yellow triangle side of the machine.

Index No.	Description	Schematic Item	Function	Torque
1	Flow control valve, 1.5 gpm / 5.7 L/min	BI	Right front steer cylinder retract circuit	20-25 ft-lbs / 27-34 Nm
2	Check valve	BC	Prevents right front steer cylinder from moving when not steering	20-25 ft-lbs / 27-34 Nm
3	Check valve	BB	Prevents left front steer cylinder from moving when not steering	20-25 ft-lbs / 27-34 Nm
4	Flow regulator valve, 2.1 gpm / 8 L/min	BL	Right rear steer cylinder extend circuit	20-25 ft-lbs / 27-34 Nm
5	Solenoid valve, 3 position 4 way	BQ	Steer left/right, right rear steer cylinder	20-25 ft-lbs / 27-34 Nm
6	Check valve	BE	Prevents right rear steer cylinder from moving when not steering	20-25 ft-lbs / 27-34 Nm
7	Check valve	BD	Prevents right rear steer cylinder from moving when not steering	20-25 ft-lbs / 27-34 Nm
8	Solenoid valve, 3 position 4 way	BP	Steer left/right, left rear steer cylinder	20-25 ft-lbs / 27-34 Nm
9	Flow regulator valve, 2.1 gpm / 8 L/min	BJ	Left rear steer cylinder extend circuit	20-25 ft-lbs / 27-34 Nm
10	Flow regulator valve, 7 gpm / 26.5 L/min	BS	Axle extend/retract circuit	20-25 ft-lbs / 27-34 Nm
11	Solenoid Valve, 2 position 3 way	BU	Axle retract	30-35 ft-lbs / 41-47 Nm
12	Solenoid Valve, 2 position 3 way	BT	Axle extend	30-35 ft-lbs / 41-47 Nm
13	Pressure reducing valve	BR	Axle extend/retract circuit	30-35 ft-lbs / 41-47 Nm

Manifolds

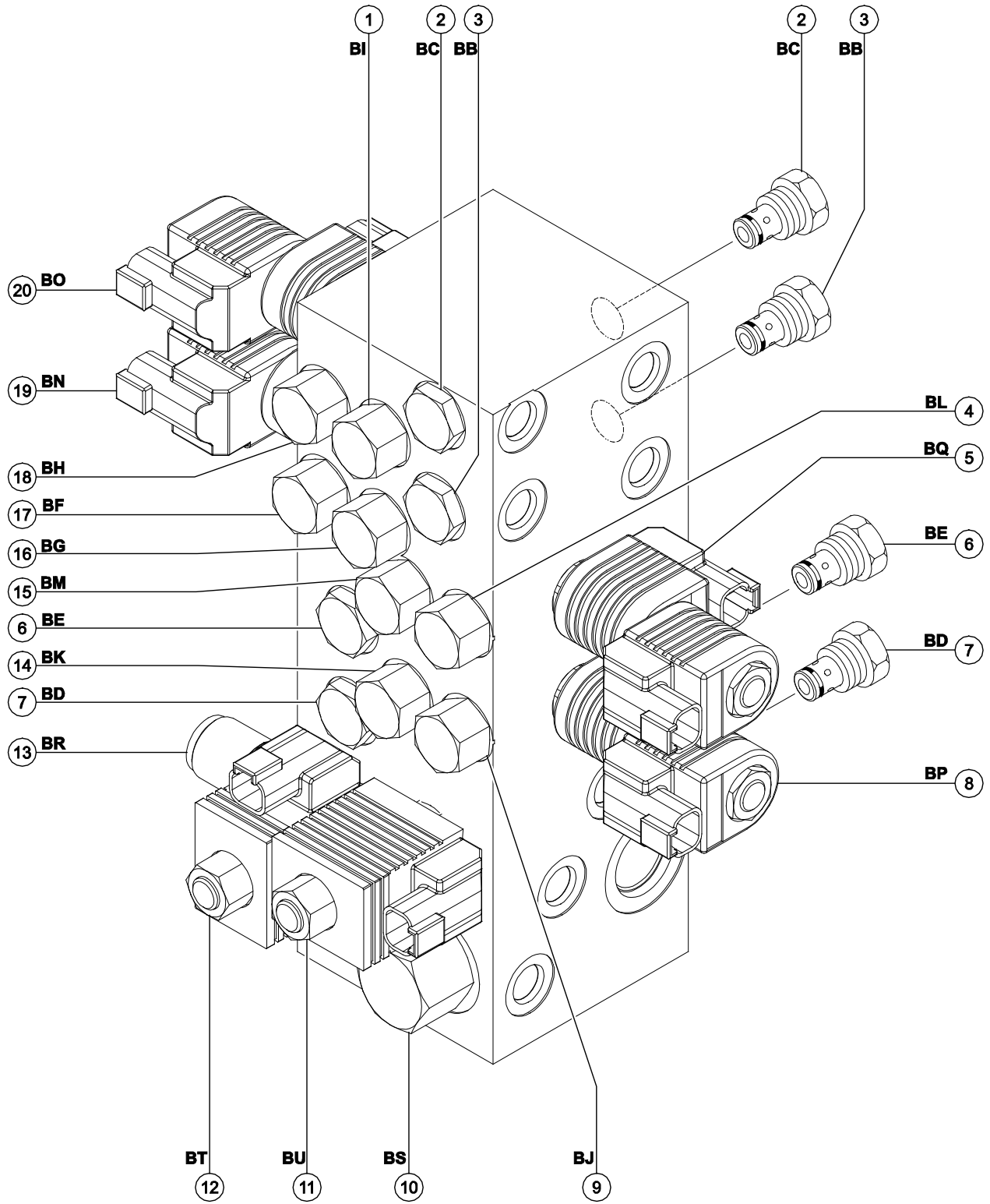

Manifolds

Steer and Axle Manifold, continued

The steer and axle manifold is mounted inside the manifold box at the yellow triangle side of the machine.

Index No.	Description	Schematic Item	Function	Torque
14	Flow regulator valve, 1.5 gpm / 5.7 L/min	BK	Left rear steer cylinder retract circuit	20-25 ft-lbs / 27-34 Nm
15	Flow regulator valve, 1.5 gpm / 5.7 L/min	BM	Right rear steer cylinder retract circuit	20-25 ft-lbs / 27-34 Nm
16	Flow regulator valve, 1.5 gpm / 5.7 L/min	BG	Left front steer cylinder retract circuit	20-25 ft-lbs / 27-34 Nm
17	Flow regulator valve, 2.1 gpm / 8 L/min	BF	Left front steer cylinder extend circuit	20-25 ft-lbs / 27-34 Nm
18	Flow regulator valve, 2.1 gpm / 8 L/min	BH	Right front steer cylinder extend circuit	20-25 ft-lbs / 27-34 Nm
19	Solenoid valve, 3 position 4 way	BN	Steer left/right, left front steer cylinder	20-25 ft-lbs / 27-34 Nm
20	Solenoid valve, 3 position 4 way	BO	Steer left/right, right front steer cylinder	20-25 ft-lbs / 27-34 Nm

Manifolds

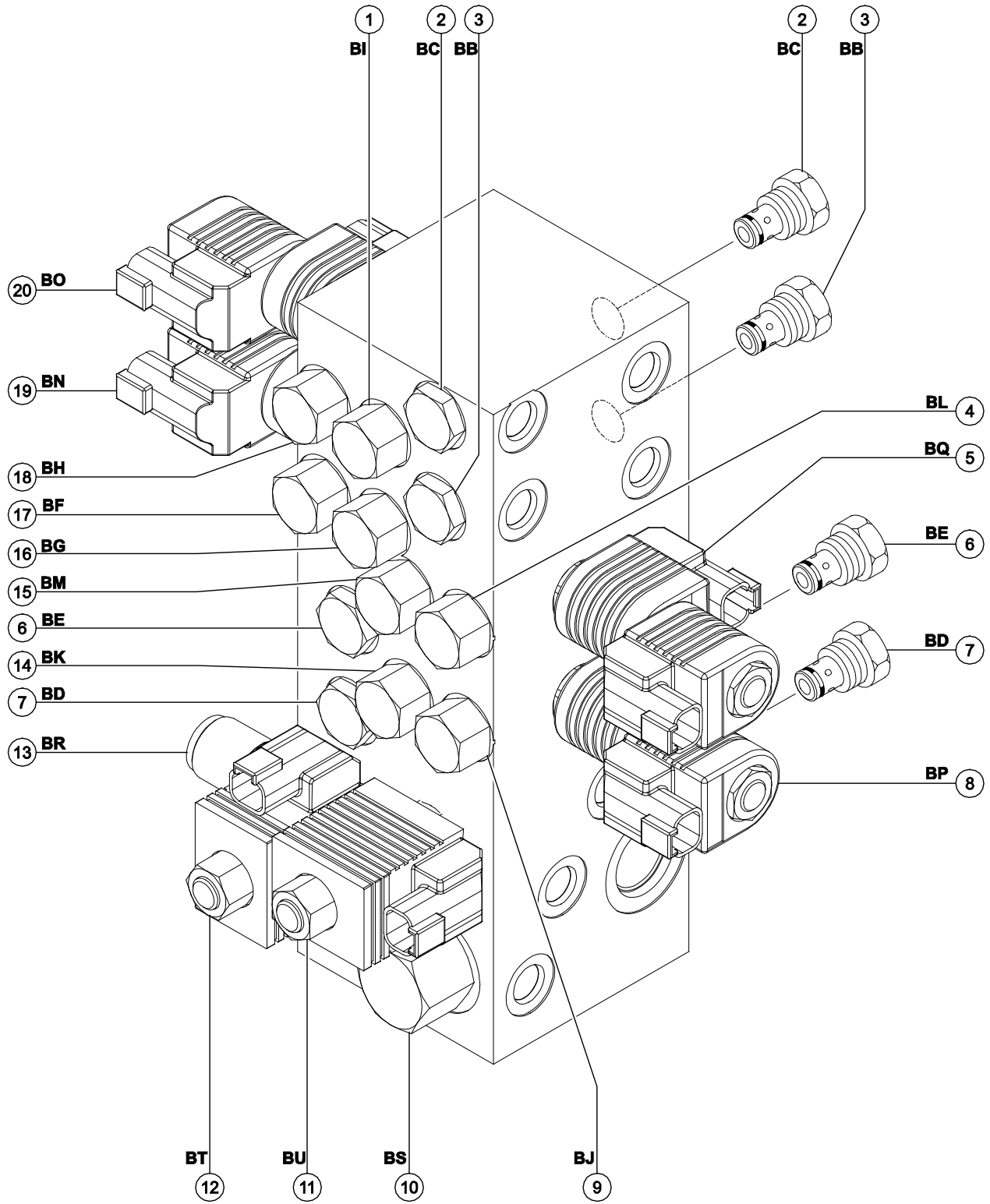

Manifolds

8-10 Valve Adjustments - Steer and Axle Manifold

How to Adjust the Axle Relief Valve

Note: Perform this procedure with the machine on a firm, level surface and in the stowed position with the axles extended.

Note: Refer to Steer and Axle Manifold list to locate the axle relief valve.

Note: Two people will be required to perform this procedure.

- 1 Connect a 0 to 5000 psi / 0 to 350 bar pressure gauge to the test port on the steer and axle manifold.
- 2 Locate the axle relief valve on the steer and axle manifold. Hold the relief valve with a wrench and remove the cap.
- 3 Start the engine from the platform controls and press down the foot switch. Press and hold the axle extend button at the platform controls. Observe the pressure reading on the pressure gauge. Refer to Specifications, *Hydraulic Component Specifications*.

- 4 Turn the engine off.
- 5 Adjust the internal hex socket. Turn it clockwise to increase the pressure or counterclockwise to decrease the pressure. Install the relief valve cap.

NOTICE Component damage hazard. Do not adjust the relief valve pressures higher than specifications.

- 6 Repeat steps 3 through 5 to confirm relief valve pressure.
- 7 Remove the pressure gauge.

This page intentionally left blank.

Manifolds

8-11

Traction Manifold - View 1

The traction manifold is mounted inside the manifold box at the blue triangle side of the machine.

Index No.	Description	Schematic Item	Function	Torque
1	Check valve, 5 psi / 0.3 bar	BA	Drive motor anti-cavitation	20-25 ft-lbs / 27.1-33.9 Nm
2	Check valve, 5 psi / 0.3 bar	AZ	Drive motor anti-cavitation	20-25 ft-lbs / 27.1-33.9 Nm
3	Check valve, 5 psi / 0.3 bar	AJ	Drive motor anti-cavitation	20-25 ft-lbs / 27.1-33.9 Nm
4	Check valve, 5 psi / 0.3 bar	AT	Drive motor anti-cavitation	20-25 ft-lbs / 27.1-33.9 Nm
5	Check valve, 5 psi / 0.3 bar	AW	Brake circuit	20-25 ft-lbs / 27.1-33.9 Nm
6	Shuttle Valve, 3 position 3 way	AO	Charge pressure circuit that directs hot oil out of low pressure side of drive pump	50-55 ft-lbs / 68-75 Nm
7	Relief valve, 250 psi / 17.2 bar	AN	Charge pressure circuit	30-35 ft-lbs / 40.7-47.5 Nm
8	Solenoid Valve, 2 position 3 way	AY	Brake release	20-25 ft-lbs / 27.1-33.9 Nm
9	Solenoid Valve, 2 position 3 way	AX	Two-speed drive motor shift	20-25 ft-lbs / 27.1-33.9 Nm
10	Flow divider/combiner valve	AR	Controls flow to square end drive motors in forward and reverse	90-100 ft-lbs / 122-135.6 Nm
11	Flow divider/combiner valve	AM	Controls flow to circle end drive motors in forward and reverse	90-100 ft-lbs / 122-135.6 Nm
12	Flow divider/combiner valve	AP	Controls flow to flow divider/combiner valves AR and AM in forward and reverse	90-100 ft-lbs / 122-135.6 Nm

Manifolds

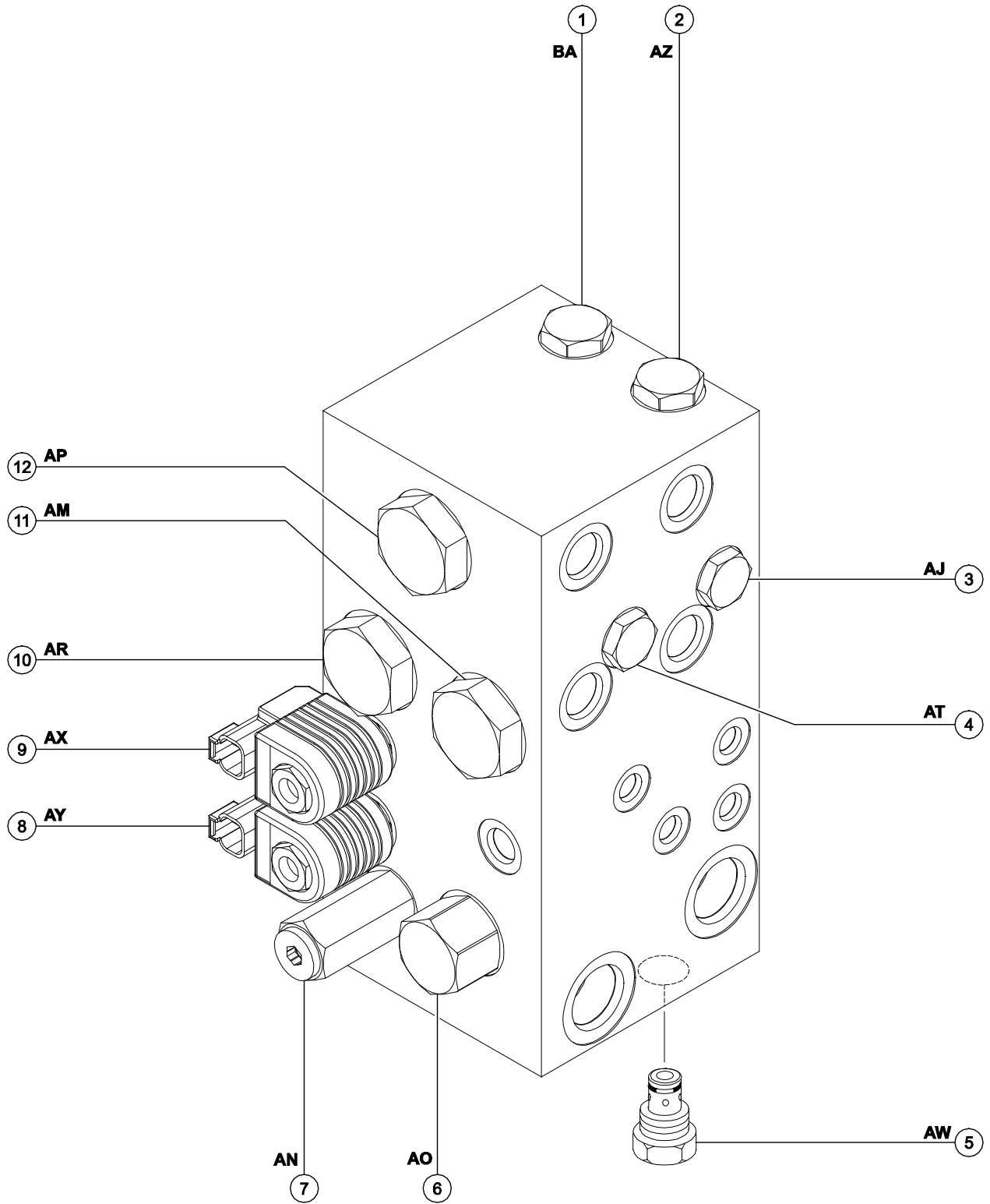

Manifolds

Traction Manifold - View 2

Index No.	Description	Schematic Item	Function	Torque
1	Orifice, 0.063 in / 1.6 mm (before serial number 180 except for serial number 102)	AL	Equalizes pressure on both sides of divider/combiner valve AM	
-	Orifice, 0.039 in / 1 mm (serial number 102 and after serial number 179)	AL	Equalizes pressure on both sides of divider/combiner valve AM	
2	Orifice, 0.052 in / 1.3 mm	AQ	Equalizes pressure on both sides of divider/combiner valve AP	
3	Orifice, 0.063 in / 1.6 mm	AS	Equalizes pressure on both sides of divider/combiner valve AR	
4	Orifice, 0.030 in / 0.76 mm	AV	Brake and two-speed circuit	
5	Check valve, 5 psi / 0.3 bar	AU	Drive motor anti-cavitation	20-25 ft-lbs / 27-34 Nm
6	Check valve, 5 psi / 0.3 bar	AK	Drive motor anti-cavitation	20-25 ft-lbs / 27-34 Nm

Manifolds

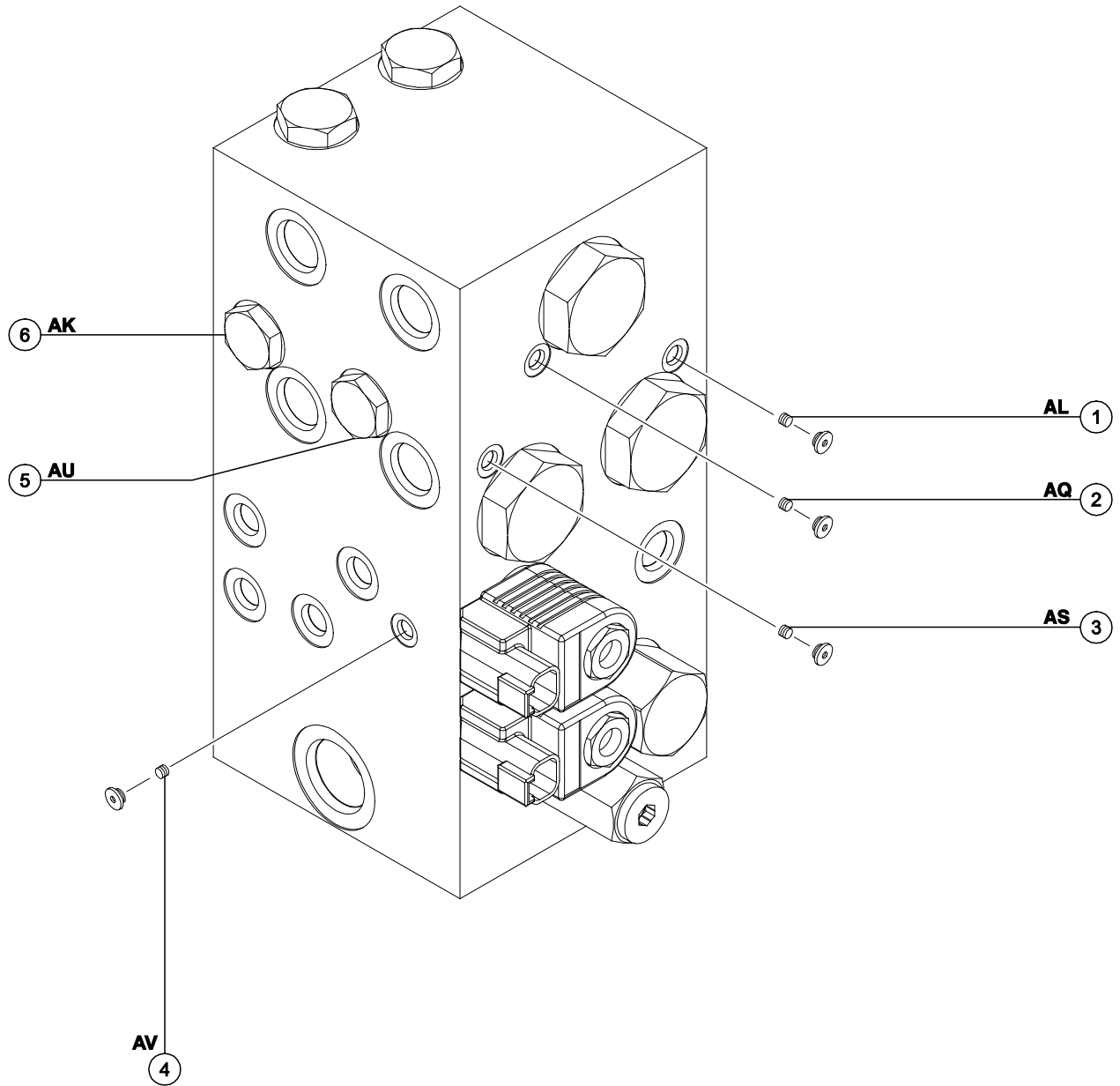

Manifolds

8-12 Valve Adjustments - Traction Manifold

How to Adjust the Hot Oil Relief Valve

Note: The hydraulic oil temperature must be 100°F to 150°F / 38°C to 65.5°C before performing this procedure.

- 1 Connect a 0 to 600 psi / 0 to 50 bar pressure gauge to either the "A" or "B" test port on the drive pump.
- 2 Locate the hot oil relief valve on the traction manifold. Hold the relief valve and remove the cap.
- 3 Turn the internal hex socket clockwise fully until it stops. Install the cap.
- 4 Start the engine from the ground controls.
- 5 Press and hold the function enable/high rpm select button (rabbit symbol) position. Note the reading on the pressure gauge.
- 6 Turn the engine off.
- 7 Remove the pressure gauge from the drive pump. Connect the gauge to the test port located on the traction manifold.
- 8 Hold the hot oil relief valve and remove the cap.
- 9 Start the engine from the ground controls.
- 10 Press and hold the function enable/high rpm select button (rabbit symbol) position.
- 11 Adjust the internal hex socket until the pressure reading on the gauge is 40 psi / 2.8 bar less than the pressure reading on the pump. Turn it clockwise to increase the pressure or counterclockwise to decrease the pressure. Install the relief valve cap.
- 12 Turn the engine off.
- 13 Remove the pressure gauge.

Manifolds

8-13 Drive Oil Diverter Manifold (welder option)

The oil diverter manifold is mounted to the hydraulic generator located in the engine compartment.

Index No.	Description	Schematic Item	Function	Torque
1	Directional valve	BV	Diverter valve	80-90 ft-lbs / 108-122 Nm
2	Orifice, 0.030 inch / 0.080 cm	BW	Delays shift to drive	
3	Solenoid Valve	BX	Pilot valve to diverter	35-40 ft-lbs / 47-54 Nm
4	Relief valve, 270 psi / 18.6 bar	BZ	Charge pressure circuit	35-40 ft-lbs / 47-54 Nm
5	Check valve	BY	Prevents oil to generator	35-40 ft-lbs / 47-54 Nm

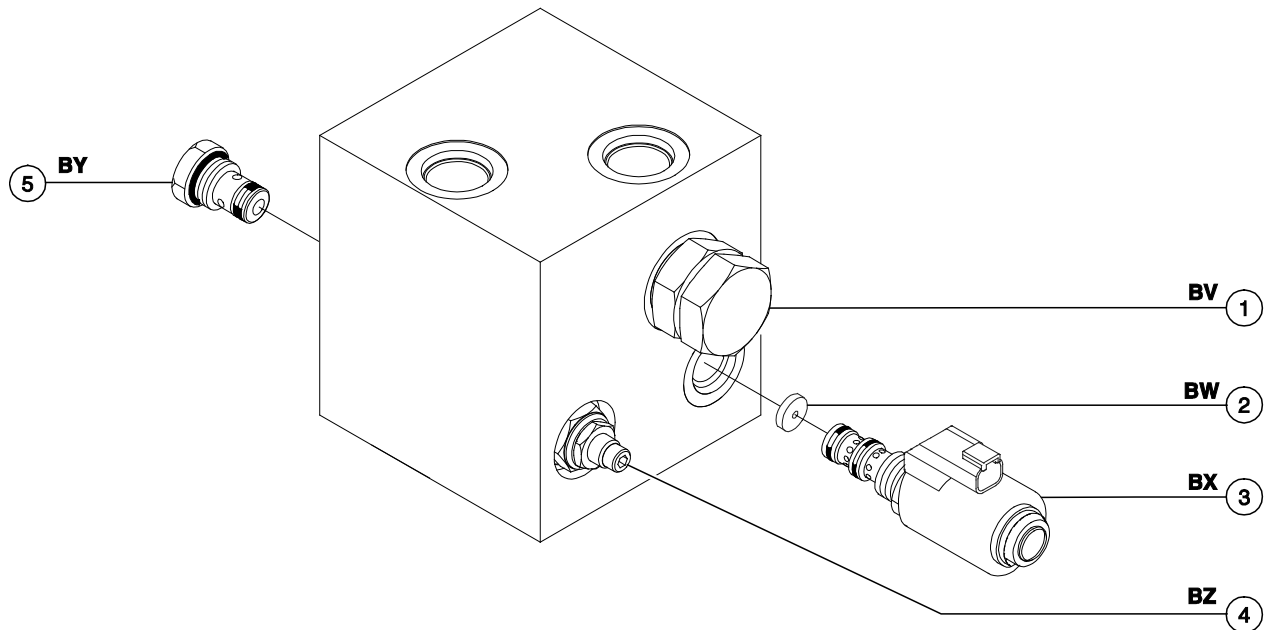

Manifolds

8-14 Valve Coils

How to Test a Coil

A properly functioning coil provides an electromotive force which operates the solenoid valve. Critical to normal operation is continuity within the coil that provides this force field.

Since coil resistance is sensitive to temperature, resistance values outside specification can produce erratic operation. When coil resistance decreases below specification, amperage increases. As resistance rises above specification, voltage increases.

While valves may operate when coil resistance is outside specification, maintaining coils within specification will help ensure proper valve function over a wide range of operating temperatures.

⚠ WARNING

Electrocution/burn hazard. Contact with electrically charged circuits could result in death or serious injury. Remove all rings, watches and other jewelry.

- 1 Tag and disconnect the wiring from the coil to be tested.
- 2 Test the coil resistance.
 - ⦿ Result: The resistance should be within specification, plus or minus 30%.
 - ⊗ Result: If the resistance is not within specification, plus or minus 30%, replace the coil.

Valve Coil Resistance Specification

Note: The following coil resistance specifications are at an ambient temperature of 68°F / 20°C. As valve coil resistance is sensitive to changes in air temperature, the coil resistance will typically increase or decrease by 4% for each 18°F / 10°C that your air temperature increases or decreases from 68°F / 20°C.

Valve Coil Resistance Specification

Proportional solenoid valve (schematic items N, P, R, T, V)	3.5 to 5.5Ω
Solenoid valve, 3 position 4 way (schematic item B)	4 to 6Ω
Solenoid valve, 3 position 4 way (schematic items BN, BO, BP, BQ)	7 to 9Ω
Solenoid valve, 3 position 4 way (schematic item AH)	8 to 10Ω
Proportional solenoid valve, 3 position 4 way (schematic items Y, AI)	8 to 10Ω
Solenoid Valve, 2 position 3 way (schematic items F, AD)	5.5 to 7.5Ω
Solenoid Valve, 2 position 3 way (schematic item AE, AF)	8 to 10Ω
Solenoid Valve, 2 position 3 way (schematic items H, J)	3.5 to 5.5Ω
Solenoid Valve, 2 position 3 way (schematic items C, D, G, I, K, AX, AY, BU, BT)	7.5 to 9.5Ω
Solenoid valve, 2 position 2 way (schematic item A)	3.5 to 5.5Ω

Manifolds

How to Test a Coil Diode

Properly functioning coil diodes protect the electrical circuit by suppressing voltage spikes. Voltage spikes naturally occur within a function circuit following the interruption of electrical current to a coil. Faulty diodes can fail to protect the electrical system, resulting in a tripped circuit breaker or component damage.

⚠ WARNING Electrocutation/burn hazard. Contact with electrically charged circuits could result in death or serious injury. Remove all rings, watches and other jewelry.

- 1 Test the coil for resistance. Refer to Repair Procedure, *How to Test a Coil*.
- 2 Connect a 10W resistor to the negative terminal of a known good 9V DC battery. Connect the other end of the resistor to a terminal on the coil.

Resistor 10Ω

Genie part number 27287

Note: The battery should read 9V DC or more when measured across the terminals.

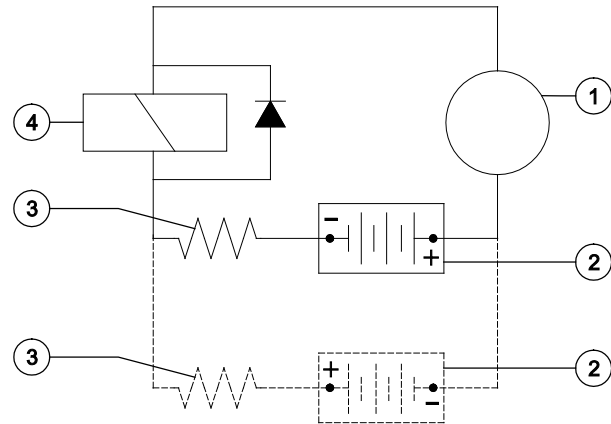

- 1 multimeter
- 2 9v DC battery
- 3 10Ω resistor
- 4 coil

Note: Dotted lines in illustration indicate a reversed connection as specified in step 6.

- 3 Set a multimeter to read DC current.
- Note: The multimeter, when set to read DC current, should be capable of reading up to 800 mA.
- 4 Connect the negative lead to the other terminal on the coil.
 - 5 Momentarily connect the positive lead from the multimeter to the positive terminal on the 9V DC battery. Note and record the current reading.
 - 6 At the battery or coil terminals, reverse the connections. Note and record the current reading.
- ⊙ Result: Both current readings are greater than 0 mA and are different by a minimum of 20%. The coil is good.
 - ⊗ Result: If one or both of the current readings are 0 mA, or if the two current readings do not differ by a minimum of 20%, the coil and/or its internal diode are faulty and the coil should be replaced.

Turntable Rotation Components

9-1 Turntable Rotation Assembly

How to Remove a Turntable Rotation Assembly

Note: When removing a hose assembly or fitting, the O-ring (if equipped) on the fitting and/or hose end must be replaced. All connections must be torqued to specification during installation. Refer to Specifications, *Hydraulic Hose and Fitting Torque Specifications*.

Note: Perform this procedure with the primary boom between the circle-end tires and with the machine on a firm, level surface.

- 1 Secure the turntable from rotating with the turntable rotation lock pin.
- 2 Remove the ground controls side fixed turntable cover.
- 3 Tag, disconnect the hydraulic hoses from the turntable rotation motor. Cap the fittings on the motor.

⚠ WARNING Bodily injury hazard. Spraying hydraulic oil can penetrate and burn skin. Loosen hydraulic connections very slowly to allow the oil pressure to dissipate gradually. Do not allow oil to squirt or spray.

- 4 Attach a lifting strap from an overhead crane or other suitable lifting device to the lifting eye on the turntable rotation assembly.

- 5 Remove the drive hub mounting bolts and remove the turntable rotation assembly from the machine.
- 6 Repeat steps 3 through 5 for the other turntable rotation assembly.

⚠ DANGER Tip-over hazard. If the turntable rotation lock pin is not properly installed, machine stability is compromised and the machine could tip over when the drive hub is removed from the machine, which could result in death or serious injury.

⚠ WARNING Crushing hazard. The drive hub could become unbalanced and fall if not properly supported by an overhead crane or lifting device when removed from the machine.

Note: When installing a turntable rotation assembly, the rotation gear backlash must be adjusted. Refer to Repair Procedure, *Adjust the Turntable Rotation Gear Backlash*.

Turntable Rotation Components

How to Adjust the Turntable Rotation Gear Backlash

- 1 Secure the turntable from rotating with the turntable rotation lock pin.
- 2 Remove the fixed turntable cover at the ground controls side of the machine.
- 3 Loosen the backlash pivot plate mounting bolts.
- 4 Push the backlash pivot plate towards the turntable as far as possible (this will push the rotation pinion gears into the turntable bearing ring gear).
- 5 Loosen the lock nut on the adjustment bolt.
- 6 Turn the adjustment bolt clockwise until it contacts the backlash pivot plate.
- 7 Turn the adjustment bolt 1/2 to 3/4 turn counterclockwise. Tighten the lock nut on the adjustment bolt.
- 8 Pull the backlash pivot plate away from the turntable until it contacts the adjustment bolt. Then lubricate the mounting fasteners on the backlash pivot plate and torque to specification. Refer to Specifications, *Machine Torque Specifications*.
- 9 Rotate the turntable through an entire rotation. Check for tight spots that could cause binding. Readjust if necessary.

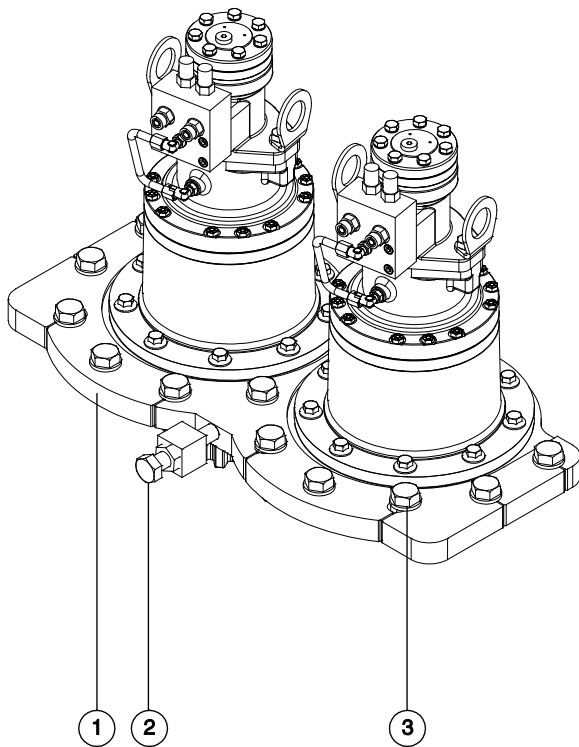

- 1 backlash pivot plate
- 2 adjustment bolt with lock nut
- 3 backlash pivot plate mounting bolts

Turntable Rotation Components

9-2

Turntable Level Sensor

How to Calibrate the Turntable Level Sensor

Note: If the Safety Controller (SCON) has been replaced, the entire machine must be calibrated in a specific order. Refer to Repair Procedure, *Full Machine Calibration*.

⚠ WARNING

Tip-over hazard. Failure to properly calibrate the machine could cause the machine to tip over resulting in death or serious injury.

Note: A digital level will be required to perform this procedure.

Note: A kit is available through Genie Product Support (Genie part number 58351). This kit includes a digital level with a magnetic base and cable harnesses.

Note: Use the following chart to identify the description of each LCD screen control button used in this procedure.



Plus



Minus



Previous



Enter

Note: Perform this procedure with the machine on a firm, level surface with the booms in the fully stowed position and the axles fully extended.

- 1 Push in the ground controls red Emergency Stop button to the off position.
- 2 Open the ground control box.

Before serial number 321:

- 3 Locate the 2 pin connector in the lower left hand area of the ground control box.
- 4 Remove the connector plug and insert a jumper wire between the two pins of the connector.

After serial number 320:

- 5 Locate the calibration toggle switch at the top of the ground control box. Activate calibration mode by moving the toggle switch in the left direction.
- 6 Temporarily install a control box door retaining fastener between the door and the box to prevent the control box door from moving the toggle switch while calibrating the machine.

Turntable Rotation Components

All models:

- 7 Turn the key switch to ground controls.
- 8 Remove the key from the main key switch. Insert the key into the bypass/recovery key switch and turn it to the bypass position.

Note: The angle sensor calibration values will not be saved correctly unless the key switch is in the bypass position and the calibration toggle switch is activated.

- 9 Press and hold the **enter** button on the ground control panel while pulling out the ground controls red Emergency Stop button to the on position. Hold the **enter** button for approximately 5 seconds and then release it.

- 10 Enter sensor calibration mode by pressing the buttons at the ground controls in the following sequence: **(plus)(enter)(enter)(plus)**.

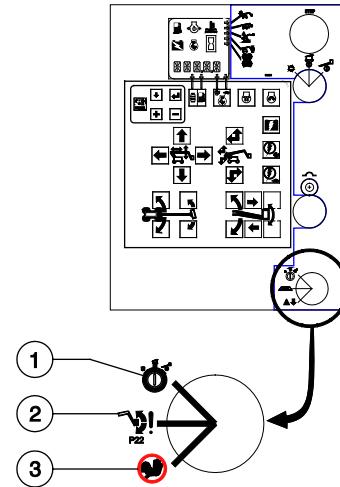

- 1 Run
- 2 Bypass
- 3 Recovery

Note: The bypass/recovery key switch is located on the lower right side of the control box from serial number Z13512-1712.

- 11 Press the **enter** or **previous** button on the LCD screen until SET UNIT X AXIS LEVEL TO GRAVITY is displayed.

Turntable Rotation Components

- Place a digital level that has been calibrated to gravity on the X axis of the turntable.

Note: Illustrations shown at the platform end of the machine.

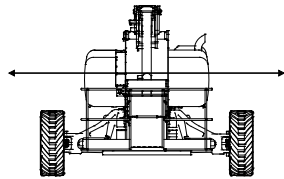

X axis

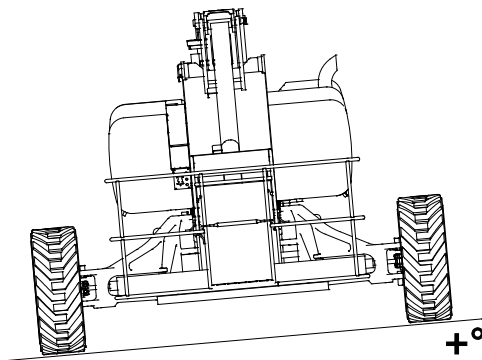

positive degree side slope

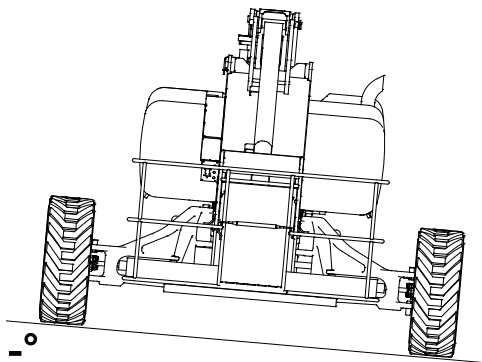

negative degree side slope

- Press the **plus** button or **minus** button to adjust the display to the exact value shown on the digital level and press the **enter** button.

Note: If the measured angle already matches the angle shown on the display at the ground controls, press the **plus** button or **minus** button to change the angle and then change back to the measured value. The system must detect a change in displayed value to record the calibrated value.

- Press the **enter** or **previous** button on the LCD screen, until SET UNIT Y AXIS LEVEL TO GRAVITY is displayed.

- Place a digital level that has been calibrated to gravity on the Y axis of the turntable.

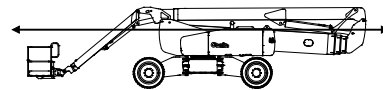

Y axis

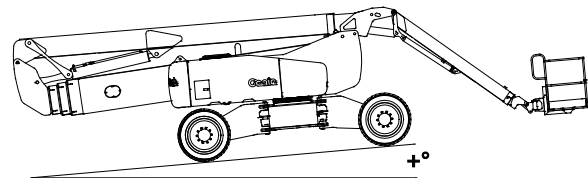

positive degree downhill slope

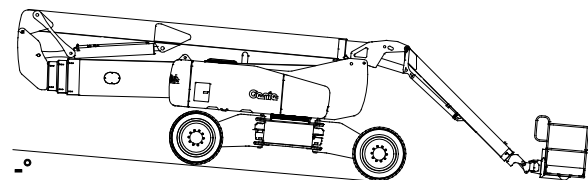

negative degree uphill slope

Turntable Rotation Components

- 16 Press the **plus** button or **minus** button to adjust the display to the exact value shown on the digital level and press the **enter** button.

Note: If the measured angle already matches the angle shown on the display at the ground controls, press the **plus** button or **minus** button to change the angle and then change back to the measured value. The system must detect a change in displayed value to record the calibrated value.

- 17 Press the **enter** or **previous** button on the LCD screen until EXIT is displayed.
- 18 Press the **plus** button to select YES, then press the **enter** button to accept.
- 19 Turn the key back to the run position and remove the key from the bypass/recovery key switch. Insert the key into the main key switch and turn it to ground controls.

Note: Be sure that the bypass/recovery key switch is in the run position before attempting to operate the machine.

- 20 Wait approximately 20 seconds and turn the machine off by pressing the red Emergency Stop button in.

Before serial number 321:

- 21 Remove the wire jumper from the 2 pin connector in the lower left hand area of the ground control box that was installed in step 4. Install the connector plug.

⚠ DANGER

Tip-over hazard. Failure to remove the jumper wire will result in an unsafe configuration which will compromise machine stability. Operating the machine in this configuration will result in the machine tipping over, resulting in death or serious injury. The jumper wire must be removed before operating the machine.

- 22 Close the ground control box and install the door retaining fasteners.

After serial number 320:

- 23 Remove the fastener that was temporarily installed. Close the control box door and install the door retaining fasteners.

Note: When the control box door is closed, the calibration toggle switch is automatically activated to exit out of calibration mode.

All models:

- 24 Start the engine. Be sure there are no calibration faults shown on the display.
- 25 Perform level sensor test. Refer to Maintenance Procedure, *Test the Level Sensor*.

Axle Components

10-1 Steer Sensors

The steer sensors measure steer angle and communicates that information to the ground controls ECM. The steer sensor on the ground controls side of the machine at the square-end acts as the lead sensor when in front wheel steer mode. In rear wheel steer mode, the steer sensor on the ground controls side of the machine at the circle-end acts as the lead sensor. The other three sensors follow the position, or steer angle, of the lead sensor. There is a steer sensor mounted to the top of each steer yoke upper pivot pin.

How to Replace a Steer Sensor

Note: When the steer sensor is replaced, both the sensor and magnet must be replaced as a set.

Note: Perform this procedure with the axles fully retracted and the boom in the stowed position.

- 1 Align the remaining wheels on the machine so they are visually parallel to the chassis as close as possible.
- 2 Disconnect the steer sensor assembly cable from the main harness to be replaced.

- 3 Remove the steer sensor cover retaining fasteners. Remove the steer sensor assembly.

Note: If the sensor activator pin needs to be replaced, install the new activator pin per Illustration 1.

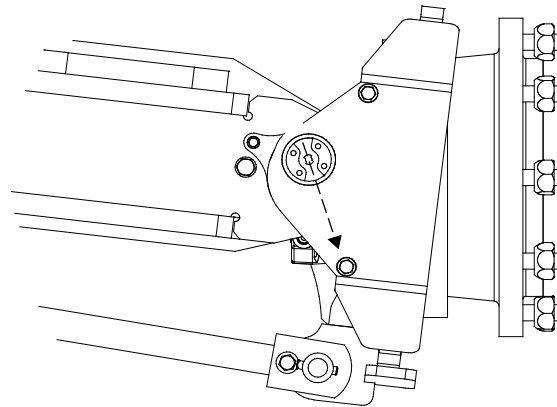

Illustration 1
(square end, yellow side and circle end, blue side shown)

Axle Components

Left front (square-end, blue side) and right rear (circle-end, yellow side) angle sensors:

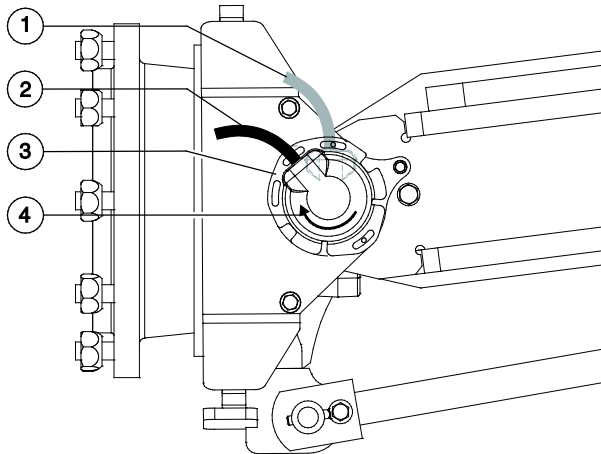

Illustration 2

- 1 starting position
- 2 installed position
- 3 sensor cover
- 4 rotation arrow

- 4 Position the new steer sensor assembly over the sensor activator pin with the sensor cable angled towards the tire. Refer to Illustration 2.
- 5 Align the sensor with the pin and install the sensor on to the pin.

Note: Be sure the sensor activator pin is engaged into the sensor.

- 6 Rotate the sensor housing in a clockwise direction until the sensor cable is pointing away from the machine. Refer to Illustration 2.

- 7 Install the steer sensor cover retaining fasteners. Do not tighten the cover retaining fasteners.
- 8 Connect the steer sensor assembly cable to the main harness.
- 9 Calibrate the steer sensor. Refer to Repair Procedure, *How to Calibrate a Replacement Steer Sensor*.

Note: Be sure the yoke pivot pin retaining plate is fully engaged into the pivot pin and that the fasteners are securely tightened.

Right front (square-end, yellow side) and left rear (circle-end, blue side) angle sensors:

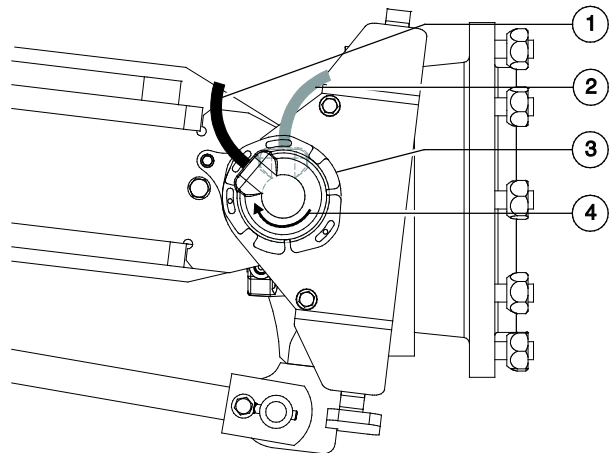

Illustration 3

- 1 installed position
- 2 starting position
- 3 sensor cover
- 4 rotation arrow

Axle Components

10 Position the new steer sensor assembly over the sensor activator pin with the sensor cable angled away from the tire. Refer to Illustration 3.

11 Align the sensor with the pin and install the sensor on to the pin.

Note: Be sure the sensor activator pin is engaged into the sensor.

12 Rotate the sensor housing in a clockwise direction until the sensor cable is pointing away from the machine. Refer to Illustration 2.

13 Install the steer sensor cover retaining fasteners. Do not tighten the cover retaining fasteners.

14 Connect the steer sensor assembly cable to the main harness.

15 Calibrate the steer sensor. Refer to Repair Procedure, *How to Calibrate a Replacement Steer Sensor*.

Note: Be sure the yoke pivot pin retaining plate is fully engaged into the pivot pin and that the fasteners are securely tightened.

How to Calibrate a Replacement Steer Sensor

Note: If a steer angle sensor has been removed or replaced, the steer angle sensors will need to be calibrated.

Note: Perform this procedure with the axles retracted and the tires straightened.

Note: Two people will be required to perform this procedure.

Note: Be sure the yoke pivot pin retaining plate is fully engaged into the pivot pin and that the fasteners are securely tightened.

1 Start the engine from the platform controls.

2 Select the proper steer mode. If a front (square-end) steer angle sensor has been replaced, select rear steer mode. If a rear (circle-end) steer angle sensor has been replaced, select front steer mode.

3 Have another person press down the foot switch.

4 At the new steer angle sensor, loosen the steer angle sensor cover retaining fasteners. Do not remove the fasteners or the sensor cover.

5 Rotate the sensor cover clockwise or counterclockwise until the tire is straight in relation with the other tires. Tighten the sensor cover fasteners.

Note: If available, WebGPI can also be used for this procedure.

6 Push in the red Emergency Stop button to the off position.

Axle Components

How to Calibrate All Steer Sensors

Note: This procedure will only need to be performed if the ground controls circuit board (TCON) has been replaced.

Note: Perform this procedure with the axles retracted and the tires straightened.

Note: Use the following chart to identify the description of each LCD screen control button used in this procedure.



Plus



Minus



Previous



Enter

Before serial number 321:

- 1 Locate the 2 pin connector in the lower left hand area of the ground control box.
- 2 Remove the connector plug and insert a jumper wire between the two pins of the connector.

After serial number 320:

- 3 Locate the calibration toggle switch at the top of the ground control box. Activate calibration mode by moving the toggle switch in the left direction.
- 4 Temporarily install a control box door retaining fastener between the door and the box to prevent the control box door from moving the toggle switch while calibrating the machine.

All models:

- 5 Turn the key switch to ground controls and pull out the ground controls red Emergency Stop button to the on position.
- 6 Loosen the steer angle sensor cover retaining fasteners. Do not remove the fasteners or the sensor cover.
- 7 Using a voltmeter set to DC voltage, probe the back of the electrical connector at pins B and C.
- 8 **Left front (square-end, blue side) and right rear (circle-end, yellow side) angle sensors:** Rotate the sensor cover clockwise or counterclockwise until the voltage reading is between 1.4 to 1.6V DC. Tighten the sensor cover fasteners.
- Right front (square-end, yellow side) and left rear (circle-end, blue side) angle sensors:** Rotate the sensor cover clockwise or counterclockwise until the voltage reading is between 3.4 to 3.6V DC. Tighten the sensor cover fasteners.

Note: If available, WebGPI can also be used for this procedure.

- 9 Remove the key from the main key switch. Insert the key into the bypass/recovery key switch and turn it to the bypass position.

Note: The angle sensor calibration values will not be saved correctly unless the key switch is in the bypass position and the calibration toggle switch is activated.

- 10 Push in the red Emergency Stop button to the off position.

Axle Components

- Press and hold the **enter** button on the ground control panel while pulling out the ground controls red Emergency Stop button to the on position. Hold the **enter** button for approximately 5 seconds and then release it.

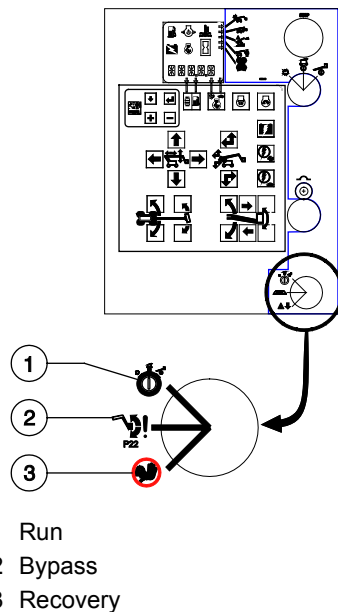

Note: The bypass/recovery key switch is located on the lower right side of the control box from serial number Z13512-1712.

- Enter sensor calibration mode by pressing the buttons at the ground controls in the following sequence: **(plus)(enter)(enter)(plus)**.

Delete all Steer Sensor Calibrations

- Press the **enter** or **previous** button on the LCD screen until DELETE ALL STEER SENSORS CALIBRATION is displayed. Press the **plus** button to select YES, then press the **enter** button to accept.

Note: Models before software version 3.0, the LCD screen will display RESET ALL STEER SENSORS.

- Press the **enter** or **previous** button on the LCD screen until EXIT is displayed.
- Press the **plus** button to select YES, then press the **enter** button to accept.
- Proceed to step 22.

Delete a Single Steer Sensor Calibration

- To calibrate a single steer sensor, delete the specific steer sensor calibration
- Press the **enter** or **previous** button on the LCD screen until DELETE ____ STEER SENSORS CALIBRATION is displayed. Example: DELETE BLUE END BLUE SIDE STEER SENSORS CALIBRATION (FL).
- Press the **plus** button to select YES, then press the **enter** button to accept.
- Press the **enter** or **previous** button on the LCD screen until EXIT is displayed.
- Press the **plus** button to select YES, then press the **enter** button to accept.

Axle Components

- 22 Push in the red Emergency Stop button to the off position.

Before serial number 321:

- 23 Remove the wire jumper from the 2 pin connector in the lower left hand area of the ground control box that was installed in step 2. Install the connector plug.

⚠ DANGER

Tip-over hazard. Failure to remove the jumper wire will result in an unsafe configuration which will compromise machine stability. Operating the machine in this configuration will result in the machine tipping over, resulting in death or serious injury. The jumper wire must be removed before operating the machine.

- 24 Close the ground control box and install the door retaining fasteners.

After serial number 320:

- 25 Remove the fastener that was temporarily installed. Close the control box door and install the door retaining fasteners.

Note: When the control box door is closed, the calibration toggle switch is automatically activated to exit out of calibration mode.

All models:

- 26 Turn the key back to the run position and remove the key from the bypass/recovery key switch. Insert the key into the main key switch and turn it to ground controls.

Note: Be sure that the bypass/recovery key switch is in the run position before attempting to operate the machine.

10-2 Steer Cylinders

How to Remove a Steer Cylinder

Note: When removing a hose assembly or fitting, the O-ring (if equipped) on the fitting and/or hose end must be replaced. All connections must be torqued to specification during installation. Refer to Specifications, *Hydraulic Hose and Fitting Torque Specifications*.

Note: Perform this procedure with the axles extended.

- 1 Tag, disconnect and plug the hydraulic hoses from the steer cylinder. Cap the fittings on the cylinder.

⚠ WARNING

Bodily injury hazard. Spraying hydraulic oil can penetrate and burn skin. Loosen hydraulic connections very slowly to allow the oil pressure to dissipate gradually. Do not allow oil to squirt or spray.

- 2 Support the steer cylinder with a suitable lifting device. Protect the cylinder rod from damage.
- 3 Remove the pin retaining fasteners from both steer cylinder pivot pins.
- 4 Use a soft metal drift to remove the pins.
- 5 Remove the steering cylinder from the machine.

⚠ CAUTION

Crushing hazard. The steer cylinder may become unbalanced and fall if not properly supported by the lifting device when removed from the machine.

Axle Components

10-3 Axle Extension Cylinders

How to Remove an Axle Extension Cylinder

Note: When removing a hose assembly or fitting, the O-ring (if equipped) on the fitting and/or hose end must be replaced. All connections must be torqued to specification during installation. Refer to Specifications, *Hydraulic Hose and Fitting Torque Specifications*.

Note: Perform this procedure with the machine on a firm, level surface and in the stowed position with the axles extended.

Note: This procedure will require the use of a portable hydraulic power unit.

- 1 Tag, disconnect and plug the hydraulic hoses from the axle extension cylinder. Cap the fittings on the cylinder.

⚠ WARNING

Bodily injury hazard. Spraying hydraulic oil can penetrate and burn skin. Loosen hydraulic connections very slowly to allow the oil pressure to dissipate gradually. Do not allow oil to squirt or spray.

- 2 Remove the axle extension limit switch cover fasteners. Remove the cover.
- 3 Remove the limit switch mounting fasteners and remove the limit switch. Do not disconnect the wiring.

- 4 Connect the hydraulic hoses from a portable hydraulic power unit to the axle extension cylinder.

Note: Connect the pressure hose from the power unit to the "R" port of the cylinder and the return hose from the power unit to the "E" port on the cylinder.

- 5 Support the axle extension cylinder with a suitable lifting device. Protect the cylinder rod from damage.
- 6 Remove the pin retaining fasteners from both axle extension cylinder pivot pins.
- 7 Use a soft metal drift to remove the pins.
- 8 Using the portable hydraulic power unit, retract the axle extension cylinder until the ends of the cylinder clear the axles.
- 9 Remove the axle extension cylinder from the machine.

⚠ CAUTION

Crushing hazard. The axle extension cylinder may become unbalanced and fall if not properly supported by the lifting device.

Axle Components

10-4 Axle Angle Sensors

The axle angle sensors measure the axle angle and communicates that information to the ground controls ECM. There are two axle angle sensors. They are located on opposite axle pivot pins at each end of the chassis.

How to Install an Axle Angle Sensor

Note: If an axle angle sensor has been removed or replaced, the axle angle sensors will need to be calibrated.

Note: Perform this procedure with the axles fully retracted and the boom in the stowed position.

- 1 Locate the axle angle sensor to be replaced.
- 2 Tag and disconnect the angle sensor electrical connector from the chassis harness.
- 3 Remove the angle sensor cover retaining fasteners. Remove the angle sensor assembly.

Note: Inspect the sensor activator pin to make sure it is not broken or twisted.

Note: If the sensor activator pin needs to be replaced, install the new activator pin parallel with the drive chassis side plate. Refer to illustration 1.

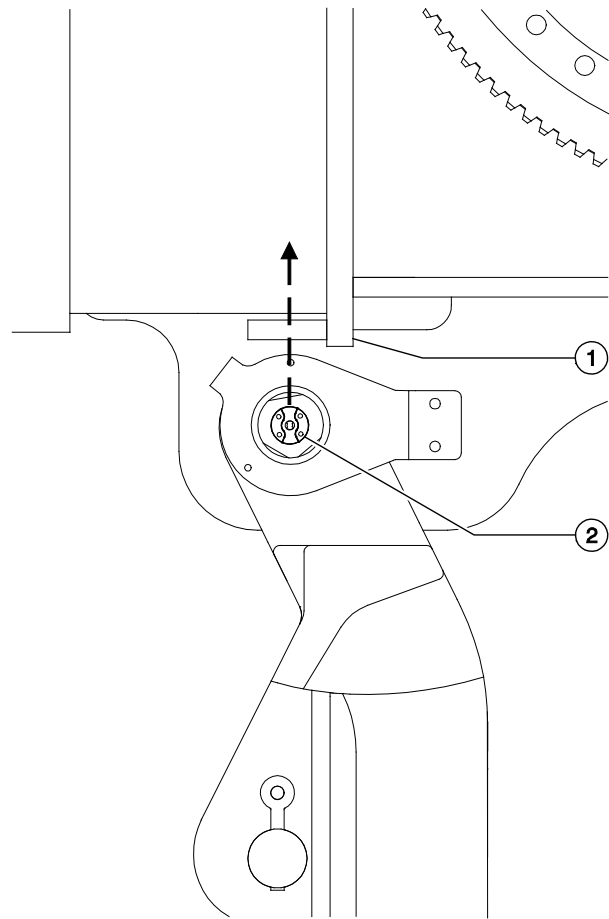

illustration 1

- 1 drive chassis side plate
- 2 activator pin

Axle Components

- 4 Position the new angle sensor assembly over the sensor activator pin as shown. Refer to illustration 2.

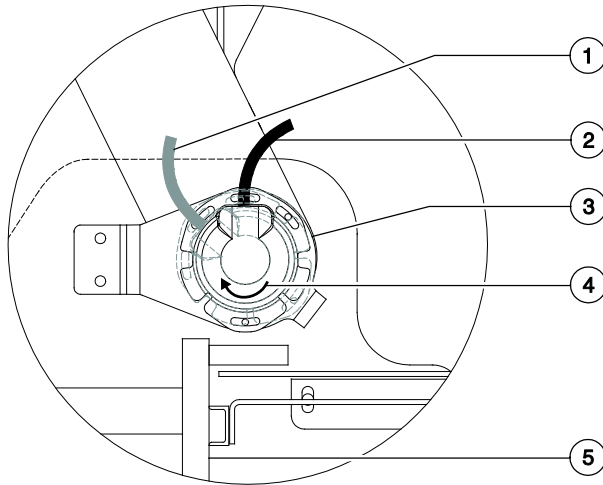

illustration 2

- 1 starting position
- 2 installed position
- 3 sensor cover
- 4 rotation arrow
- 5 drive chassis side plate

- 5 Align the sensor with the pin and install the sensor on to the pin.

Note: Be sure the actuator pin is engaged into the sensor.

- 6 Rotate the sensor housing in a clockwise direction until the sensor cable is parallel with the drive chassis side plate. Refer to illustration 2.
- 7 Install the axle sensor cover retaining fasteners. Do not tighten the retaining fasteners.
- 8 Connect the axle sensor assembly cable to the chassis harness.
- 9 Calibrate the axle angle sensor. Refer to Repair Procedure, *How to Calibrate the Axle Angle Sensors*.

Axle Components

How to Calibrate the Axle Angle Sensors

Note: Use the following chart to identify the description of each LCD screen control button used in this procedure.



Plus



Minus



Previous



Enter

Note: If an axle angle sensor has been removed or replaced, the axle angle sensors will need to be calibrated.

Note: Perform this procedure with the axles fully retracted and the boom in the stowed position.

Note: Two people will be required to perform this procedure.

- 1 Turn the key switch to platform controls and pull out the red Emergency Stop button to the on position at both ground and platform controls.
- 2 Loosen the axle angle sensor cover retaining fasteners. Do not remove the fasteners or the sensor cover.
- 3 Using a voltmeter set to DC voltage, probe the back of the electrical connector at pins 2 and 3.
- 4 Rotate the sensor cover clockwise or counterclockwise until the voltage reading is between 4.2 to 4.4V DC. Tighten the sensor cover retaining fasteners.
- 5 Repeat steps 2 through 4 for the other axle angle sensor if needed.
- 6 Push in the ground controls red Emergency Stop button to the off position.
- 7 Open the ground control box.

Before serial number 321:

- 8 Locate the 2 pin connector in the lower left hand area of the ground control box.
- 9 Remove the connector plug and insert a jumper wire between the two pins of the connector.

After serial number 320:

- 10 Locate the calibration toggle switch at the top of the ground control box. Activate calibration mode by moving the toggle switch in the left direction.
- 11 Temporarily install a control box door retaining fastener between the door and the box to prevent the control box door from moving the toggle switch while calibrating the machine.

Note: If available, WebGPI can also be used for this procedure.

Axle Components

All models:

- 12 Remove the key from the main key switch. Insert the key into the bypass/recovery key switch and turn it to the bypass position.

Note: The angle sensor calibration values will not be saved correctly unless the key switch is in the bypass position and the calibration toggle switch is activated.

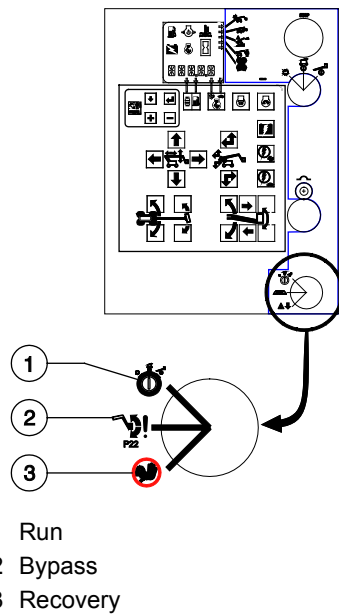

Note: The bypass/recovery key switch is located on the lower right side of the control box from serial number Z13512-1712.

- 13 Press and hold the **enter** button on the ground control panel while pulling out the ground controls red Emergency Stop button to the on position. Hold the **enter** button for approximately 5 seconds and then release it.
- 14 Enter sensor calibration mode by pressing the buttons at the ground controls in the following sequence: **(plus)(enter)(enter)(plus)**.
- 15 Press the **enter** or **previous** button on the LCD screen until DELETE AXLE ANGLE SENSORS CALIBRATION is displayed. Press the **plus** button to select YES, then press the **enter** button to accept.

Note: Models before software version 3.0, the LCD screen will display RESET AXLE ANGLE SENSORS.

- 16 At the AXLE ANGLES FULLY RETRACTED screen, press the **plus** button to select YES, then press the **enter** button to accept.
- 17 When the AXLE ANGLES FULLY EXTENDED screen is displayed, start the engine and fully extend the axles.

Note: If the system exits out of calibration mode when the engine is started, repeat step 13.

Axle Components

- 18 Press the **plus** button to select YES, then press the **enter** button to accept.
- 19 Press the **enter** or **previous** button on the LCD screen until EXIT is displayed.
- 20 Press the **plus** button to select YES, then press the **enter** button to accept.
- 21 Press and hold the engine start button for approximately 5 seconds to shut off the engine and to save the calibration settings.

Note: Do not turn the engine off with the key switch or red Emergency Stop button or all calibration points or values will not be saved.

- 22 Wait approximately 20 seconds and turn the machine off by pressing the red Emergency Stop button in.

Before serial number 321:

- 23 Remove the wire jumper from the 2 pin connector in the lower left hand area of the ground control box that was installed in step 8. Install the connector plug.

DANGER

Tip-over hazard. Failure to remove the jumper wire will result in an unsafe configuration which will compromise machine stability. Operating the machine in this configuration will result in the machine tipping over, resulting in death or serious injury. The jumper wire must be removed before operating the machine.

- 24 Close the ground control box and install the door retaining fasteners.

After serial number 320:

- 25 Remove the fastener that was temporarily installed. Close the control box door and install the door retaining fasteners.

Note: When the control box door is closed, the calibration toggle switch is automatically activated to exit out of calibration mode.

All models:

- 26 Turn the key back to the run position and remove the key from the bypass/recovery key switch. Insert the key into the main key switch and turn it to ground controls.

Note: Be sure that the bypass/recovery key switch is in the run position before attempting to operate the machine.

This page intentionally left blank.

Fault Codes



Observe and Obey:

- ☑ Troubleshooting and repair procedures shall be completed by a person trained and qualified on the repair of this machine
- ☑ Immediately tag and remove from service a damaged or malfunctioning machine.
- ☑ Repair any machine damage or malfunction before operating the machine.
- ☑ Unless otherwise specified, perform each procedure with the machine in the following configuration:
 - Machine parked on a firm, level surface
 - Key switch in the off position with the key removed
 - The red Emergency Stop button in the off position at both the ground and platform controls
 - Wheels chocked
 - All external AC power supply disconnected from the machine
 - Boom in the stowed position
 - Turntable secured with the turntable rotation lock
 - Welder disconnected from the machine (if equipped with the weld cable to platform option)

Before Troubleshooting:

- ☑ Read, understand and obey the safety rules and operating instructions in the appropriate operator's manual on your machine.
- ☑ Be sure that all necessary tools and test equipment are available and ready for use.
- ☑ Read each appropriate fault code thoroughly. Attempting short cuts may produce hazardous conditions.
- ☑ Be aware of the following hazards and follow generally accepted safe workshop practices.

▲ WARNING

Electrocution/burn hazard. Contact with electrically charged circuits could result in death or serious injury. Remove all rings, watches and other jewelry.

Note: Two persons will be required to safely perform some troubleshooting procedures.

Fault Codes

Error Source	Error Type	Effects	Recovery Actions
Primary Ext/Ret Joystick	Value at 5.0 V	Limited Speed and Direction frozen at zero and neutral, Alarm sounds	Check for damaged wiring to the joystick. Check the connections to ensure the connector terminals have not backed out. Substitute a known good joystick. If necessary replace and recalibrate joystick.
	Value Too High		
	Value Too Low		
	Value at 0 V		
	Not calibrated	Joystick Speed and Direction frozen at zero and neutral	Calibrate Joystick
	Just calibrated	Initiate one second beep of audible warning device	Self-clearing (transient)
Primary Up/Down Joystick	Value at 5.0 V	Limited Speed and Direction frozen at zero and neutral, Alarm sounds	Check for damaged wiring to the joystick. Check the connections to ensure the connector terminals have not backed out. Substitute a known good joystick. If necessary replace and recalibrate joystick.
	Value Too High		
	Value Too Low		
	Value at 0 V		
	Not calibrated	Joystick Speed and Direction frozen at zero and neutral	Calibrate Joystick
	Just calibrated	Initiate one second beep of audible warning device	Self-clearing (transient)
Steer Joystick	Value at 5.0 V	Limited Speed and Direction frozen at zero and neutral, Alarm sounds	Check for damaged wiring to the joystick. Check the connections to ensure the connector terminals have not backed out. Substitute a known good joystick. If necessary replace and recalibrate joystick.
	Value Too High		
	Value Too Low		
	Value at 0 V		
	Not calibrated	Joystick Speed and Direction frozen at zero and neutral	Calibrate Joystick
	Just calibrated	Initiate one second beep of audible warning device	Self-clearing (transient)

Fault Codes

Error Source	Error Type	Effects	Recovery Actions
Primary Boom Up/Down buttons on TCON	Fault Check (both buttons pressed)	Primary Boom Up/Down disabled, display message on LCD	Check ribbon and connector from membrane switch. If necessary replace membrane switch.
Primary Boom Ext/Ret buttons on TCON	Fault Check (both buttons pressed)	Primary Boom Ext/Retract disabled, display message on LCD	Check ribbon and connector from membrane switch. If necessary replace membrane switch.
Primary Boom Length	Fault Check (unknown length)	Stop all boom functions, allow only boom retract, once fully retracted allow boom down. Display message on LCD	Check primary boom retracted and extended switches for proper contact with the boom. Readjust or shim switch as necessary.
Primary Up/Down Speed	Not calibrated	Display message on LCD and allow operation at default speed	Perform auto calibrate procedure.
Primary Extend/Retract Speed	Not calibrated	Display message on LCD and allow operation at default speed	Perform auto calibrate procedure.
Primary Boom Extend Valve	Fault Check	Limited Speed and Direction frozen at zero and neutral, Alarm sounds	Check for defective or damaged wiring. Check for an open or shorted valve coil. Repair or replace as necessary.
Primary Boom Retract Valve			
Primary Boom Up Valve			
Primary Boom Down Valve			
Primary Lock-Out Valve #1			
Primary Lock-Out Valve #2			
Secondary Boom Up/Down/Extend/Retract Flow Valve	Not calibrated	Normal function except threshold for one or the other direction is zero. Display message on LCD	Perform calibration procedure
	Just calibrated	Initiate one second beep of audible warning device	Self-clearing (transient)
	Value Too High	Limited Speed and Direction frozen at zero and neutral, Alarm sounds	Check for opens in the wiring or a bad ground. Replace coil if necessary
	Value Too Low	Limited Speed and Direction frozen at zero and neutral, Alarm sounds	Check for opens in the wiring or a bad ground. Replace coil if necessary

Fault Codes

Error Source	Error Type	Effects	Recovery Actions
Safety Switch P3	Fault Check	Display message on LCD P3 SAFETY SWITCH FAULT	Internal fault not on Z135
Safety Switch P6R1	Fault Check	Display message on LCD P6R1 SAFETY SWITCH FAULT	Check wiring for circuit P53LS (white/black wire) for damage resulting in shorts or opens. Repair wiring or replace TCON.
Safety Switch P6R2	Fault Check	Display message on LCD P6R2 SAFETY SWITCH FAULT	Check wiring for circuit P54ENG (black/white wire) for damage resulting in shorts or opens. Repair wiring or replace TCON.
Safety Switch P7	Fault Check	Display message on LCD P7 SAFETY SWITCH FAULT	Check wiring for circuit S56PRV (red wire) for damage resulting in shorts or opens. Repair wiring or replace TCON.
Safety Switch P7R	Fault Check	Display message on LCD P7R SAFETY SWITCH FAULT	Function enable button was held down during startup. Recycle power with the function button released.
Safety Switch DCON P7R	Fault Check	Display message on LCD DCON P7R SAFETY SWITCH FAULT	Check wiring for circuit S56PRV (red wire) for damage resulting in shorts or opens. Repair wiring or replace DCON.
Safety Switch P9A	Fault Check	Display message on LCD P9A SAFETY SWITCH FAULT	Check wiring for circuit P53LS (white/black wire) for damage resulting in shorts or opens. Repair wiring or replace TCON.
Safety Switch P9B	Fault Check	Display message on LCD P9B SAFETY SWITCH FAULT	Boom has violated the safety limits resulting in the engine being shut off as a safety feature. Use aux to get the boom back into operational limits. Check P54ENG and P58LS between SCON and TCON for damage. Check SCON chart for possible fault conditions.

Fault Codes

Error Source	Error Type	Effects	Recovery Actions
Safety Switch P10	Fault Check	Display message on LCD P10 SAFETY SWITCH FAULT	Recycle power
Safety Switch P11	Fault Check	Display message on LCD P11 SAFETY SWITCH FAULT	Recycle power and check wiring on circuit S140ENL (orange/black) between SCON and TCON. Check SCON chart for possible faults.
Safety Switch P12	Fault Check	Display message on LCD P12 SAFETY SWITCH FAULT	Recycle power
Safety Switch P14	Fault Check	Display message on LCD P14 SAFETY SWITCH FAULT	Recycle power
Safety Switch P18	Fault Check	Display message on LCD P18 SAFETY SWITCH FAULT	Recycle power
Safety Switch P22	Fault Check	Display message on LCD P22 SAFETY SWITCH FAULT	Re-level platform. Check for wiring damage on circuit P56PRV (red/white).
Safety Switch P22R	Fault Check	Display message on LCD P22R SAFETY SWITCH FAULT	Re-level platform. Repair or replace PCON.
Safety Switch P30	Fault Check	Display message on LCD P30 SAFETY SWITCH FAULT	Recycle power and check wiring on circuit S140ENL (orange/black) between SCON and TCON. Check SCON chart for possible faults.
Safety Switch P38	Fault Check	Display message on LCD P38 SAFETY SWITCH FAULT	Recycle power and check wiring on circuit S137PLL (red/white) between SCON and TCON. Check SCON chart for possible faults.
Safety Switch P39	Fault Check	Display message on LCD P39 SAFETY SWITCH FAULT	Recycle power and check wiring on circuit S139TRF (white/red) between SCON and TCON. Check SCON chart for possible faults.

Fault Codes

Error Source	Error Type	Effects	Recovery Actions
Platform Overload	Fault Check (if active)	Display message on LCD. Disable all functions from PCON. Limit functions at TCON to AUX Power. FUEL POWER P9B FAULT	Check for an overload in the platform. Check the overload switch mounted on the platform support.
Footswitch Timeout	Calibration check	Display message on LCD	Recycle power
Engine Speed	Range Check (underspeed)	Display message on LCD	Engine is running below 50 RPM. Check fuel system.
Oil Pressure	Range Check (low oil pressure)	Display message on LCD	Oil pressure is low. Check sender and oil level.
Water/Oil Temperature	Range Check (high temp)	Display message on LCD	Engine is overheating. Check sender, water or oil level or radiator/heat exchanger.
Oil Pressure Sender	Fault Check	Display message on LCD	Check wiring to senders for opens or shorts. Repair or replace senders.
Water/Oil Temp Sender			
Axle Extend/Retract Buttons	Fault Check (both buttons pressed)	Axle extend/retract disabled. Display message on LCD	Check ribbon and connector from membrane switch. If necessary replace membrane switch.
Axle Valve	Fault Check	Limited Speed and Direction frozen at zero and neutral, Alarm sounds	Check for defective or damaged wiring. Check for an open or shorted valve coil. Repair or replace as necessary.
DCON CAN Bus	Fault Check	Display message on LCD Disable propel	Check CAN bus wiring from TCON to DCON through rotator. Repair or replace wiring or DCON.
CAN Bus	Fault Check	Display message on LCD	Check CAN bus wiring from TCON to SCON/PCON. Repair or replace wiring or SCON/PCON.

Fault Codes

Error Source	Error Type	Effects	Recovery Actions
Primary Boom Up/Down Flow Valve	Not calibrated	Normal function except threshold for one or the other direction is zero. Display message on LCD	Calibrate Thresholds
	Just calibrated	Initiate one second beep of audible warning device	Self-clearing (transient)
	Value Too High	Limited Speed and Direction frozen at zero and neutral, Alarm sounds	Check for opens in the wiring or a bad ground. Replace coil if necessary
	Value Too Low		
Primary Boom Extend/Retract Flow Valve	Not calibrated	Normal function except threshold for one or the other direction is zero. Display message on LCD	Calibrate Thresholds
	Just calibrated	Initiate one second beep of audible warning device	Self-clearing (transient)
	Value Too High	Limited Speed and Direction frozen at zero and neutral, Alarm sounds	Check for opens in the wiring or a bad ground. Replace coil if necessary
	Value Too Low		
Operational Primary Boom Angle Sensor	Value at 5.0 V	Primary up, Secondary up/down and Extend disabled, Alarm sounds	Check for an open ground circuit going to the sensor
	Value Too High	Primary up, Secondary up/down and Extend disabled, Alarm sounds	Sensor is out of range. Check sensor and actuating pin for proper installation. Repair or replace sensor and recalibrate.
	Value Too Low		
	Value at 0 V	Primary up, Secondary up/down and Extend disabled, Alarm sounds	Check for 5.0 VDC at the sensor. Check for damaged wiring going to the sensor. Check that the % .0 VDC LED is lit on the TCON board. Repair or replace as necessary
	Out of Tolerance	Primary up, Secondary up/down and Extend disabled, Alarm sounds	Recalibrate sensor
	Not calibrated	Primary up only active from TCON, activate alarm	Perform calibration procedure per service manual
	Just calibrated	Initiate one second beep of audible warning device	Self-clearing (transient)

Fault Codes

Error Source	Error Type	Effects	Recovery Actions
Safety Primary Boom Angle Sensor	Value at 5.0 V	Primary up, Secondary up/down and Extend disabled, Alarm sounds	Check for an open ground circuit going to the sensor
	Value Too High	Primary up, Secondary up/down and Extend disabled, Alarm sounds	Sensor is out of range. Check sensor and actuating pin for proper installation. Repair or replace sensor and recalibrate.
	Value Too Low		
	Value at 0 V	Primary up, Secondary up/down and Extend disabled, Alarm sounds	Check for 5.0 VDC at the sensor. Check for damaged wiring going to the sensor. Check that the % .0 VDC LED is lit on the TCON board. Repair or replace as necessary
	Out of Tolerance	Primary up, Secondary up/down and Extend disabled, Alarm sounds	Recalibrate sensor
	Not calibrated	Primary up only active from TCON, activate alarm	Perform calibration procedure per service manual
	Just calibrated	Initiate one second beep of audible warning device	Self-clearing (transient)
Secondary Boom Joystick	Value at 5.0 V	Primary up, Secondary up/down and Extend disabled, Alarm sounds	Check for damaged wiring to the joystick. Check the connections to ensure the connector terminals have not backed out. Substitute a known good joystick. If necessary replace and recalibrate joystick.
	Value Too High		
	Value Too Low		
	Value at 0 V		
	Not calibrated	Joystick Speed and Direction frozen at zero and neutral	
	Just calibrated	Initiate one second beep of audible warning device	Self-clearing (transient)
Secondary Boom Up/Extend/Down/Retract Switches on TCON	Fault Check (both buttons pressed)	Secondary boom Up/Ext/Down/Retract disabled Display message on LCD	Check ribbon and connector from membrane switch. If necessary replace membrane switch.
Secondary Boom Up/Down Speed	Not calibrated	Display message on LCD and allow operation at default speed	See service manual on how to perform this procedure.

Fault Codes

Error Source	Error Type	Effects	Recovery Actions
Secondary Boom Extend Valve	Fault Check	Limited Speed and Direction frozen at zero and neutral, Alarm sounds	Check for defective or damaged wiring. Check for an open or shorted valve coil. Repair or replace as necessary.
Secondary Boom Retract Valve	Fault Check	Limited Speed and Direction frozen at zero and neutral, Alarm sounds	Check for defective or damaged wiring. Check for an open or shorted valve coil. Repair or replace as necessary.
Secondary Boom Up Valve	Fault Check	Limited Speed and Direction frozen at zero and neutral, Alarm sounds	Check for defective or damaged wiring. Check for an open or shorted valve coil. Repair or replace as necessary.
Secondary Boom Down Valve	Fault Check	Limited Speed and Direction frozen at zero and neutral, Alarm sounds	Check for defective or damaged wiring. Check for an open or shorted valve coil. Repair or replace as necessary.
Secondary Boom Extend Sequence Valve	Fault Check	Limited Speed and Direction frozen at zero and neutral, Alarm sounds	Check for defective or damaged wiring. Check for an open or shorted valve coil. Repair or replace as necessary.
Secondary Boom Down Sequence Valve	Fault Check	Limited Speed and Direction frozen at zero and neutral, Alarm sounds	Check for defective or damaged wiring. Check for an open or shorted valve coil. Repair or replace as necessary.
Operational Secondary Boom Angle Sensor	Value at 5.0 V	Primary up, Secondary up/down and Extend disabled, Alarm sounds	Check for an open ground circuit going to the sensor
	Value Too High	Primary up, Secondary up/down and Extend disabled, Alarm sounds	Sensor is out of range. Check sensor and actuating pin for proper installation. Repair or replace sensor and recalibrate.
	Value Too Low		
	Value at 0 V	Primary up, Secondary up/down and Extend disabled, Alarm sounds	Check for 5.0 VDC at the sensor. Check for damaged wiring going to the sensor. Check that the % .0 VDC LED is lit on the TCON board. Repair or replace as necessary
	Out of Tolerance	Primary up, Secondary up/down and Extend disabled, Alarm sounds	Recalibrate sensor
	Not calibrated	Secondary up only active from TCON, activate alarm	Perform calibration procedure per service manual
	Just calibrated	Initiate one second beep of audible warning device	Self-clearing (transient)

Fault Codes

Error Source	Error Type	Effects	Recovery Actions
Safety Secondary Boom Angle Sensor	Value at 5.0 V	Primary up, Secondary up/down and Extend disabled, Alarm sounds	Check for an open ground circuit going to the sensor
	Value Too High	Primary up, Secondary up/down and Extend disabled, Alarm sounds	Sensor is out of range. Check sensor and actuating pin for proper installation. Repair or replace sensor and recalibrate.
	Value Too Low		
	Value at 0 V	Primary up, Secondary up/down and Extend disabled, Alarm sounds	Check for 5.0 VDC at the sensor. Check for damaged wiring going to the sensor. Check that the % .0 VDC LED is lit on the TCON board. Repair or replace as necessary
	Out of Tolerance	Primary up, Secondary up/down and Extend disabled, Alarm sounds	Recalibrate sensor
	Not calibrated	Secondary up only active from TCON, activate alarm	Perform calibration procedure per service manual
	Just calibrated	Initiate one second beep of audible warning device	Self-clearing (transient)
Operational Turntable Level Sensor X Direction	Value at 5.0 V	Flash unit out of level icon and LED and activate alarm	Check that SCON is grounded
	Value Too High		Replace SCON
	Value Too Low		
	Value at 0 V		
	Out of Tolerance		
	Just calibrated	Initiate one second beep of audible warning device	Self-clearing (transient)
Safety Turntable Level Sensor X Direction	Value at 5.0 V	Flash unit out of level icon and LED and activate alarm	Check that SCON is grounded
	Value Too High		Replace SCON
	Value Too Low		
	Value at 0 V		
	Out of Tolerance		
	Just calibrated	Initiate one second beep of audible warning device	Self-clearing (transient)

Fault Codes

Error Source	Error Type	Effects	Recovery Actions
Turntable Rotate Joystick	Value at 5.0 V	Limited Speed and Direction frozen at zero and neutral, Alarm sounds	Check for damaged wiring to the joystick. Check the connections to ensure the connector terminals have not backed out. Substitute a known good joystick. If necessary replace and recalibrate joystick.
	Value Too High		
	Value Too Low		
	Value at 0 V		
	Not calibrated	Joystick Speed and Direction frozen at zero and neutral	Calibrate Joystick
	Just calibrated	Initiate one second beep of audible warning device	Self-clearing (transient)
Turntable Rotate Buttons on TCON	Fault Check (both buttons pressed)	Turntable rotate disabled Display message on LCD	Check ribbon and connector from membrane switch. If necessary replace membrane switch.
Turntable Rotate Speed	Not calibrated	Display message on LCD and allow operation at default speed	Perform auto calibrate procedure.
Turntable Rotate Flow Valve	Not calibrated	Normal function except threshold for one or the other direction is zero. Display message on LCD	Perform calibration procedure
	Just calibrated	Initiate one second beep of audible warning device	Self-clearing (transient)
	Value Too High	Limited Speed and Direction frozen at zero and neutral, Alarm sounds	Check for opens in the wiring or a bad ground. Replace coil if necessary
	Value Too Low		Check for shorts to ground in the wiring. Replace coil if necessary
Turntable Rotate Clockwise Valve	Fault Check	Limited Speed and Direction frozen at zero and neutral, Alarm sounds	Check for defective or damaged wiring. Check for an open or shorted valve coil. Repair or replace as necessary.
Turntable Rotate Counterclockwise Valve			
Operational Turntable Level Sensor Y Direction	Value at 5.0 V	Primary up and extend disabled, Alarm sounds	Check that SCON is grounded
	Value Too High		Replace SCON
	Value Too Low		
	Value at 0 V		
	Out of Tolerance		
	Just calibrated	Initiate one second beep of audible warning device	Self-clearing (transient)

Fault Codes

Error Source	Error Type	Effects	Recovery Actions
Safety Turntable Level Sensor Y Direction	Value at 5.0 V	Primary up and extend disabled, Alarm sounds	Check that SCON is grounded
	Value Too High		Replace SCON
	Value Too Low		
	Value at 0 V		
	Out of Tolerance		
	Just calibrated	Initiate one second beep of audible warning device	Self-clearing (transient)
Platform Level Sensor Y Direction	Value at 5.0 V	Primary up and extend disabled, Alarm sounds	Check that SCON is grounded
	Value Too High		
	Value Too Low		
	Value at 0 V		
	Just calibrated	Initiate one second beep of audible warning device	Self-clearing (transient)
Platform Rotate Clockwise Valve	Fault Check	Fault Check	Check for defective or damaged wiring. Check for an open or shorted valve coil. Repair or replace as necessary.
Platform Rotate Counterclockwise Valve			
Jib Extend /Retract Valve	Fault Check	Fault Check	Check for defective or damaged wiring. Check for an open or shorted valve coil. Repair or replace as necessary.
Jib Up/Down Flow Valve(s)	Not calibrated	Normal function except threshold for one or the other direction is zero. Display message on LCD	Perform calibration procedure
	Just calibrated	Initiate one second beep of audible warning device	Self-clearing (transient)
	Value Too High	Limited Speed and Direction frozen at zero and neutral, Alarm sounds	Check for opens in the wiring or a bad ground. Replace coil if necessary
	Value Too Low		

Fault Codes

Error Source	Error Type	Effects	Recovery Actions
Jib Level (Bellcrank) Up/Down Flow Valve(s)	Not calibrated	Normal function except threshold for one or the other direction is zero. Display message on LCD	Perform calibration procedure
	Just calibrated	Initiate one second beep of audible warning device	Self-clearing (transient)
	Value Too High	Limited Speed and Direction frozen at zero and neutral, Alarm sounds	Check for opens in the wiring or a bad ground. Replace coil if necessary
	Value Too Low		
Platform Level Up / Platform Level Down Flow Valve	Not calibrated	Normal function except threshold for one or the other direction is zero. Display message on LCD	Perform calibration procedure
	Just calibrated	Initiate one second beep of audible warning device	Self-clearing (transient)
	Value Too High	Limited Speed and Direction frozen at zero and neutral, Alarm sounds	Check for opens in the wiring or a bad ground. Replace coil if necessary
	Value Too Low	Limited Speed and Direction frozen at zero and neutral, Alarm sounds	Check for shorts to ground in the wiring. Replace coil if necessary
Platform Rotate Switches	Fault Check (both closed)	Affected functions disabled. Display message on LCD	Check ribbon and connector from membrane switch. If necessary replace membrane switch.
Jib Up/Down Joystick	Value at 5.0 V	Limited Speed and Direction frozen at zero and neutral, Alarm sounds	Check for damaged wiring to the joystick. Check the connections to ensure the connector terminals have not backed out. Substitute a known good joystick. If necessary replace and recalibrate joystick.
	Value Too High		
	Value Too Low		
	Value at 0 V		
	Not calibrated	Joystick Speed and Direction frozen at zero and neutral	
	Just calibrated	Initiate one second beep of audible warning device	Self-clearing (transient)

Fault Codes

Error Source	Error Type	Effects	Recovery Actions
Jib Extend/Retract Joystick	Value at 5.0 V	Limited Speed and Direction frozen at zero and neutral, Alarm sounds	Check for damaged wiring to the joystick. Check the connections to ensure the connector terminals have not backed out. Substitute a known good joystick. If necessary replace and recalibrate joystick.
	Value Too High		
	Value Too Low		
	Value at 0 V		
	Not calibrated	Joystick Speed and Direction frozen at zero and neutral	Calibrate Joystick
	Just calibrated	Initiate one second beep of audible warning device	Self-clearing (transient)
Platform Rotate Joystick	Value at 5.0 V	Limited Speed and Direction frozen at zero and neutral, Alarm sounds	Power up controller with problem corrected.
	Value Too High		
	Value Too Low		
	Value at 0 V		
	Not calibrated	Joystick Speed and Direction frozen at zero and neutral	Calibrate Joystick
	Just calibrated	Initiate one second beep of audible warning device	Self-clearing (transient)
Front Axle Angle Sensor	Value at 5.0 V	Primary up, Secondary up/down and Extend disabled, Alarm sounds	Check for an open ground circuit going to the sensor
	Value Too High	Primary up, Secondary up/down and Extend disabled, Alarm sounds	Sensor is out of range. Check sensor and actuating pin for proper installation. Repair or replace sensor and recalibrate.
	Value Too Low		
	Value at 0 V	Primary up, Secondary up/down and Extend disabled, Alarm sounds	Check for 5.0 VDC at the sensor. Check for damaged wiring going to the sensor. Check that the % .0 VDC LED is lit on the TCON board. Repair or replace as necessary
	Out of Tolerance	Primary up, Secondary up/down and Extend disabled, Alarm sounds	Recalibrate sensor
	Not calibrated	Primary up only active from TCON, activate alarm	Perform calibration procedure per service manual
	Just calibrated	Initiate one second beep of audible warning device	Self-clearing (transient)

Fault Codes

Error Source	Error Type	Effects	Recovery Actions
Rear Axle Angle Sensor	Value at 5.0 V	Primary up, Secondary up/down and Extend disabled, Alarm sounds	Check for an open ground circuit going to the sensor
	Value Too High	Primary up, Secondary up/down and Extend disabled, Alarm sounds	Sensor is out of range. Check sensor and actuating pin for proper installation. Repair or replace sensor and recalibrate.
	Value Too Low		
	Value at 0 V	Primary up, Secondary up/down and Extend disabled, Alarm sounds	Check for 5.0 VDC at the sensor. Check for damaged wiring going to the sensor. Check that the % .0 VDC LED is lit on the TCON board. Repair or replace as necessary
	Out of Tolerance	Primary up, Secondary up/down and Extend disabled, Alarm sounds	Recalibrate sensor
	Not calibrated	Primary up only active from TCON, activate alarm	Perform calibration procedure per service manual
	Just calibrated	Initiate one second beep of audible warning device	Self-clearing (transient)
Propel Joystick	Value at 5.0 V	Limited Speed and Direction frozen at zero and neutral, Alarm sounds	Check for damaged wiring to the joystick. Check the connections to ensure the connector terminals have not backed out. Substitute a known good joystick. If necessary replace and recalibrate joystick.
	Value Too High		
	Value Too Low		
	Value at 0 V		
	Not calibrated	Joystick Speed and Direction frozen at zero and neutral	Calibrate Thresholds
	Just calibrated	Initiate one second beep of audible warning device	Self-clearing (transient)
Propel Valves Forward/Reverse Propel EDC Forward/Reverse	Not calibrated	Joystick Speed and Direction frozen at zero and neutral	Calibrate Thresholds
	Just calibrated	Initiate one second beep of audible warning device	Self-clearing (transient)
	Value Too High	Limited Speed and Direction frozen at zero and neutral, Alarm sounds	Check for opens in the wiring or a bad ground. Replace coil if necessary
	Value Too Low		Check for shorts to ground in the wiring. Replace coil if necessary
Motor Valve Speed Brake Valve	Fault Check	Limited Speed and Direction frozen at zero and neutral, Alarm sounds	Check for defective or damaged wiring. Check for an open or shorted valve coil. Repair or replace as necessary.



Fault Codes

Error Source	Error Type	Effects	Recovery Actions
Left Front Steer Angle Sensor	Value at 5.0 V	Primary up, Secondary up/down and Extend disabled, Alarm sounds	Check for an open ground circuit going to the sensor
	Value Too High	Primary up, Secondary up/down and Extend disabled, Alarm sounds	Sensor is out of range. Check sensor and actuating pin for proper installation. Repair or replace sensor and recalibrate.
	Value Too Low		
	Value at 0 V	Primary up, Secondary up/down and Extend disabled, Alarm sounds	Check for 5.0 VDC at the sensor. Check for damaged wiring going to the sensor. Check that the % .0 VDC LED is lit on the TCON board. Repair or replace as necessary
Right Front Steer Angle Sensor	Value at 5.0 V	Primary up, Secondary up/down and Extend disabled, Alarm sounds	Check for an open ground circuit going to the sensor
	Value Too High	Primary up, Secondary up/down and Extend disabled, Alarm sounds	Sensor is out of range. Check sensor and actuating pin for proper installation. Repair or replace sensor and recalibrate.
	Value Too Low		
	Value at 0 V	Primary up, Secondary up/down and Extend disabled, Alarm sounds	Check for 5.0 VDC at the sensor. Check for damaged wiring going to the sensor. Check that the % .0 VDC LED is lit on the TCON board. Repair or replace as necessary
Left Rear Steer Angle Sensor	Value at 5.0 V	Primary up, Secondary up/down and Extend disabled, Alarm sounds	Check for an open ground circuit going to the sensor
	Value Too High	Primary up, Secondary up/down and Extend disabled, Alarm sounds	Sensor is out of range. Check sensor and actuating pin for proper installation. Repair or replace sensor and recalibrate.
	Value Too Low		
	Value at 0 V	Primary up, Secondary up/down and Extend disabled, Alarm sounds	Check for 5.0 VDC at the sensor. Check for damaged wiring going to the sensor. Check that the % .0 VDC LED is lit on the TCON board. Repair or replace as necessary

Fault Codes

Error Source	Error Type	Effects	Recovery Actions
Right Rear Steer Angle Sensor	Value at 5.0 V	Primary up, Secondary up/down and Extend disabled, Alarm sounds	Check for an open ground circuit going to the sensor
	Value Too High	Primary up, Secondary up/down and Extend disabled, Alarm sounds	Sensor is out of range. Check sensor and actuating pin for proper installation. Repair or replace sensor and recalibrate.
	Value Too Low		
	Value at 0 V	Primary up, Secondary up/down and Extend disabled, Alarm sounds	Check for 5.0 VDC at the sensor. Check for damaged wiring going to the sensor. Check that the % .0 VDC LED is lit on the TCON board. Repair or replace as necessary
Steer Valves - LF, RF, LR, RR	Fault Check	Limited Speed and Direction frozen at zero and neutral, Alarm sounds	Check for defective or damaged wiring. Check for an open or shorted valve coil. Repair or replace as necessary.

Fault Codes

Error Source	Error Type	Effects	Recovery Actions
Secondary Boom Switch Timeout	Too much time has elapsed from when LSS1RO is released and LSS1RS is released on extend and LSS1RS is engaged and LSS1RO is engaged. Or the joystick was engaged three times in the interval.	Inhibit Secondary Boom Extend if the fault occurs.	If the fault occurs on extend, retract boom until LSS1RO is engaged and try again. Check LSS1RS and LSS1RO for physical damage and proper operation.
Secondary Boom Switches Intermittence Fault (LSS1RS Fault)	Either LSS1RS or LSS1RO have changed state without a secondary boom extend/retract command or they have changed state when the secondary boom is not fully raised.	Inhibit Secondary Boom Down until the fault is cleared.	Check switch for proper operation or damage. Use TCON display menu or laptop with WebGPI to clear faults.
Jib Angle Sensor Operational (RSJ1AO)	Value at 5.0 V	Limited Speed and Direction frozen at zero and neutral, Alarm sounds	Power up controller with problem corrected.
	Value Too High		
	Value Too Low		
	Value at 0 V		
SCON Tilt Sensor	Calibration check	Display X direction and Y direction not calibrated	Re-power after entering tilt x axis and y axis matrix information
LSS1RO Fault	LSS1RO did not switch within a specified time after the secondary boom was raised	Inhibit secondary boom extend and sound an audible warning	Check switch for proper operation or damage. Use TCON display menu or laptop with WebGPI to clear faults.

Fault Codes

P_38 - Propel	P_39 - Turntable Rotate	P_10 - Primary Boom Extend	P_11 - Primary / Secondary Up	P_9B - Ignition/Fuel	P_30 - Secondary Extend/Down			
			P_38	P_39	P_10	P_11	P_30	P_9B
Turntable tilt Y axis (+5°, secondary boom not stowed)			OFF	OFF		OFF	OFF	
Primary Boom angle (crosscheck)			OFF	OFF	OFF	OFF	OFF	
Secondary Boom angle (crosscheck)			OFF	OFF		OFF	OFF	
Secondary Boom safety (not retracted and not raised)						OFF	OFF	OFF
Axle safety not stowed (not faulted primary and secondary stowed)				OFF	OFF	OFF	OFF	
Axle crosscheck angle sensor versus safety switch				OFF	OFF	OFF	OFF	
Axle(not fully extended) and Turntable rotate (stowed and in drive disable zone)			OFF	OFF				
Turntable tilt angle (crosscheck SCON internal sensors 3 in a delta configuration)			OFF	OFF	OFF	OFF	OFF	
Primary Boom safety (max angle)			OFF	OFF		OFF	OFF	OFF
Loss of CAN			OFF	OFF	OFF	OFF	OFF	OFF
LSS1RS disconnected (SCON pin #2)						OFF	OFF	
Platform Overload (SCON pin #1)								OFF
Secondary Boom length (crosscheck LSS1RS and LSS1RO)						OFF	OFF	OFF

This page intentionally left blank.

Schematics



Observe and Obey:

- ☑ Troubleshooting and repair procedures shall be completed by a person trained and qualified on the repair of this machine
- ☑ Immediately tag and remove from service a damaged or malfunctioning machine.
- ☑ Repair any machine damage or malfunction before operating the machine.

Before Troubleshooting:

- ☑ Read, understand and obey the safety rules and operating instructions in the appropriate operator's manual on your machine.
- ☑ Be sure that all necessary tools and test equipment are available and ready for use.

About This Section

There are two groups of schematics in this section.

Electrical Schematics

⚠ WARNING

Electrocution/burn hazard. Contact with electrically charged circuits could result in death or serious injury. Remove all rings, watches and other jewelry.

Hydraulic Schematics

⚠ WARNING

Bodily injury hazard. Spraying hydraulic oil can penetrate and burn skin. Loosen hydraulic connections very slowly to allow the oil pressure to dissipate gradually. Do not allow oil to squirt or spray.

Wire Circuit Legend

Circuit numbering

- 1 Circuit numbers consist of three parts: the circuit prefix, circuit number and circuit suffix. The circuit prefix indicates the type of circuit. The circuit number describes the function of the circuit. The circuit suffix provides an abbreviation for the number or may be used to further define the function of this portion of the circuit. It also may be used to indicate the final end of the circuit, i.e., LS or limit sw.
- 2 The circuit number may be used more than once in a circuit.

For Example:

C 74 PL – This is the circuit for the lockout valve #1. C stands for control, 74 is the number of the circuit for the primary #1 lock out valve. PL stands for Primary Lockout.

S 62 BST – This is the circuit that communicates to the onboard computers of the machine that the boom is fully stowed. S stands for safety, 62 is the number of the circuit for boom stowed and BST stands for Boom Stowed.

P 48 LP – P stands for power. 48 is the circuit number for work lamps and LP stands for Lamp.

R 48 LP – R stands for relay. In this case it is the wire that feeds the relay coil for the work lamp. All other numbers remain the same.

V61AXR – V stands for valve power. Number 61 stands for axle retracted circuit; AXR stands for Axle retracted.

R46HRN – R stands for Relay output, supplying power to the horn (HRN). Number 46 is the circuit number for the horn.

Circuit prefix

C	Control
D	Data
E	Engine
G	Gauges
N	Neutral
P	Power
R	Relay Output
S	Safety
V	Valve

Wire Circuit Legend

Suffix	Definition	Suffix	Definition
ABV	Auxiliary Boom Valve	ESP	Engine Speed Select
AF	Alternator Field	FAP	Axle Front Position
AFV	Auxiliary Forward Valve	FB	Flashing Beacon
AH	Auxiliary Hydraulic Pump	FE	Function Enable
ANG	Angle	FL	Fuel Select (gas/LP)
APV	Auxiliary Platform Valve	FLR	Filter Restricted
ARV	Auxiliary Reverse Valve	FLT	Filter Switch
ASV	Auxiliary Steer/Drive Valve	FP	Fuel Pump
AXE	Axle Extend Valve	FS	Float Switch
AXO	Axle Oscillate	FSL	Fuel Solenoid
AXR	Axle Retract Valve	FTS	Foot switch Signal
BAT	Battery	FWD	Forward
BEX	Boom Extended	GEN	AC Generator
BRK	Brake	GND	Ground
BST	Boom Stowed	HG	Hydraulic Generator
BV	Bypass Valves	HRN	Horn
CAL	Calibrate	HS	High RPM
CAN	CAN Signal	IGN	Ignition
CAT	CATS Module	JBD	Jib Bellcrank Down
CNK	Chain Break	JBE	Jib Extend
DCN	Drive Chassis Controller	JBR	Jib Retract
DE	Drive Enable	JBS	Jib Sensor
DEL	Drive Enable Left	JBU	Jib Bellcrank Up
DER	Drive Enable Right	JD	Jib Down
DTH	Data High	JER	Jib Extend/Retract Control
DTL	Data Low	JFC	Jib Up/Down Flow Control
EDC	Electrical Displacement Control	JPL	Propel Signal
ENL	Envelope Lockout	JPW	Joystick 5V DC Power
ENV	Envelope Light	JRL	Jib Rotate Left (CCW)
ERL	Extend/Retract Lockout	JRR	Jib Rotate Right (CW)
ESL	Engine Status Lamp		

Wire Circuit Legend

Suffix	Definition	Suffix	Definition
JSV	Jib Select Valve	PLF	Platform Level Flow Control
JU	Jib Up	PLL	Propel Lockout
JUD	Jib Up/Down Control	PLS	Primary Boom Extend/Retract Signal
LDS	Load Sensor	PLU	Platform Level Up
LF	Left Front	PRC	Platform Rotate Control
LFS	Left Front Steer Sensor	PRF	Platform Rotate Flow Control
LO	Lockout	PRL	Platform Rotate Left (CCW)
LOF	Low fuel	PRR	Platform Rotate Right (CW)
LPS	Lamps	PRV	Proportional Valve
LR	Left Rear	PS	Pressure Switches
LRS	Left Rear Steer Sensor	PSE	Program Setup Enable
LS	Limit Switch	PSL	Power to Length Sensor
LS	Low RPM	PSR	Pressure Sender
LSR	Lift Speed Reduction	PTA	Platform Tilt Alarm
MFV	Multi Function Valve	PTS	Platform Tilt Sensor
MS	Motor Shift (Speed)	PUD	Primary Boom Up/Down Flow Control
PBD	Primary Boom Down	PWR	Power
PBE	Primary Boom Extend	PXS	Proximity Sensor
PBL	Primary Boom Extend/Retract Lockout Valve	RAP	Axle Rear Position
PBR	Primary Boom Retract	RCV	Recovery
PBS	Primary Boom Angle Sensor	REC	Receptacle
PBU	Primary Boom Up	RET	Return
PCE	Pressure Comp Enable	REV	Reverse
PCN	Platform Control	RF	Right Front
PEL	Primary Ext/Ret Lockout	RFS	Right Front Steer Sensor
PER	Primary Boom Extend/Retract Flow Control	RL	Retract Lockout
PES	Primary Boom Up/Down Signal	RPM	RPM
PL	Primary Lockout	RR	Right Rear
PLD	Platform Level Down		

Wire Circuit Legend

Suffix	Definition	Suffix	Definition
RRS	Right Rear Steer Sensor	STR	Starter
RS	Rotary Sensor	SUD	Sec Boom Up/Down Flow Control
SA	Start Aid (Glow Plug or choke)	TAX	Tilt Alarm X axis
SB	Secondary Boom	TAY	Tilt Alarm Y axis
SBD	Sec Boom Down	TCN	Ground Control
SBE	Sec Boom Extend	TCN	Ground Control Panel
SBL	Sec Boom Elevated	TET	Tether
SBR	Sec Boom Retract	TRF	Turntable Rotate Flow Control
SBS	Sec Boom Angle Sensor	TRR	Turntable Rotate Right (CW)
SBU	Sec Boom Up	TS	Temp Switches
SCC	Steering Valve (CCW)	TSR	Temp Sender
SCW	Steering Valve (CW)	TSW	Test Switch
SEN	Sensor	TTA	Turntable Tilt Alarm
SER	Sec Boom Extend/Retract Flow Control	TTS	Turntable Tilt Sensor
SHD	CAN Shield		
SLD	Secondary Boom Lockout Valve (riser down)		
SLE	Secondary Boom Lockout Valve (extend)		
SP	Spare		
SS	Speed Sensor		
STC	Steer Control Signal		

Wire Color Legend

Wire Coloring

- 1 All cylinder extension colors are solid and all retract functions are striped black. When using black wire, the stripe shall be white.
- 2 All rotations that are LEFT or CW are solid, RIGHT or CCW are striped and black. When the wire is black, the stripe is white.
- 3 All proportional valve wiring is striped.

Power Circuits

P9A	Primary boom down valve
P9B	Engine ignition / Fuel
P10	Primary boom extend valve
P11	Primary boom up valve
P30	Secondary boom down and extend valves
P38	Propel (drive) valves
P39	Turntable rotate flow control valve

Wire Color Legend

BL	Blue
BL/BK	Blue/Black
BL/RD	Blue/Red
BL/WH	Blue/White
BK	Black
BK/RD	Black/Red
BK/WH	Black/White
BK/YL	Black/Yellow
BR	Brown
GR	Green
GR/BK	Green/Black
GR/WH	Green/White
RD	Red
RD/BK	Red/Black
RD/WH	Red/White
OR	Orange
OR/BK	Orange/Black
OR/RD	Orange/Red
WH	White
WH/BK	White/Black
WH/RD	White/Red
YL	Yellow

Wire Color Legend

Color	Circuit #	Primary Function	Color	Circuit #	Primary Function
RD	1	Primary boom up driver	WH/RD	26	Power to temp sender
RD/BK	2	Primary boom down driver	RD	27	Auxiliary Power
RD/WH	3	Primary boom up/down flow control proportional valve driver	RD/BK	28	Platform level alarm
WH	4	Turntable rotate left valve driver	RD/WH	29	Drive Motor shift (speed)
WH/BK	5	Turntable rotate right valve driver	WH	30	Forward/EDC-A
WH/RD	6	Turntable rotate flow control proportional valve driver	WH/BK	31	Reverse/EDC-B
BK	7	Primary boom extend	WH/RD	32	Brake
BK/WH	8	Primary boom retract	BK	33	Start
BK/RD	9	Primary boom Extend/Retract proportional valve driver	BK/WH	34	Start Aid (glow plug or choke)
BL	10	Secondary boom up valve driver	BK/RD	35	High Engine speed select
BL/BK	11	Secondary boom down valve driver	BL	36	Steer clockwise
BL/WH	12	Secondary boom up/down flow control proportional valve driver	BL/BK	37	Steer counterclockwise
BL/RD	13	Drive enable	BL/WH	38	Gasoline
OR	14	Platform level up valve	BL/RD	39	LPG
OR/BK	15	Platform level down valve	OR	40	Limit switch signal stowed
OR/RD	16	Platform up/down flow control proportional valve driver	OR/BK	41	RPM signal
GR	17	Platform rotate left valve driver	OR/RD	42	Boom retracted signal
GR/BK	18	Platform rotate right valve driver	GR	43	Jib Up
GR/WH	19	Jib select valve driver circuit	GR/BK	44	Jib Down
RD	20	12V DC battery supply	GR/WH	45	AC Generator
WH	21	12V DC ignition supply	WH	46	Horn
BK	22	Key switch power to platform	WH/BK	47	Output Power Enable
WH	23	Power to platform	WH/RD	48	Work Lamp
RD	24	Power to warning senders	WH/BK	49	Motion Lamp
WH/BK	25	Power to oil pressure sender	BL	50	Auxiliary Boom
			BL/WH	51	Auxiliary Steer
			BL/RD	52	Auxiliary Platform
			WH/BK	53	Boom envelope safety valve cutoff
			BK/WH	54	Power to safety interlock switches (engine)

Wire Color Legend

Color	Circuit #	Primary Function	Color	Circuit #	Primary Function
GR/BK	55	Axle oscillation	OR	86	Hydraulic Filter restricted
RD	56	Foot switch/TCON estop power	RD	87	Platform Level Safety Power
RD/WH	57	Boom down safety interlock	RD/BK	88	Platform Level Safety Output
RD/BK	58	Safety interlock to engine	BR	89	Platform Level Safety Ground
GR/WH	59	Chain break circuit	RD/BK	90	Proximity Kill
GR/WH	60	Axle extend	RD/WH	91	Gate Interlock
GR	61	Axle retract	WH/BK	92	Motor Speed (LO/HI)
OR	62	Boom stowed (safety)	WH/RD	93	Motor Bypass
OR/RD	63	Power to boom envelope safety switch	WH	94	Load Sensor
OR/BK	64	Power for operational switches	OR	95	Tether ESTOP return
BL/WH	65	Low fuel indication	RD	96	Tether Power
BL	66	Drive Enable	BK	97	Tether ESTOP Power
BL	67	Secondary boom not stowed	WH	98	J1708 + (high)
RD	68	Primary Boom lowered (operational)	BK	99	J1708- (low)
BL	69	Primary boom #1 extended	WH/RD	100	Outrigger lowered
BL/WH	70	Primary boom #2 retracted	WH/BK	101	Outrigger raised
BL/BK	71	Primary boom #2 extended	OR	102	Pothole protector up
BL/WH	72	Secondary boom extended	OR/RD	103	Pothole protector down
BL/RD	73	Secondary boom retracted	BK/WH	104	Proprietary Data buss - (I.e. ITT or AP)
RD	74	Primary #1 Lockout	BK/RD	105	Proprietary Data buss + (I.e. ITT or AP)
RD/WH	75	Primary #2 Lockout	GR	106	Spare
BL	76	Primary boom #3 extended	RD	107	Alternator Field
WH	77	Lower Angle #1 operational	BL/WH	108	Engine Status
WH/BK	78	Upper Angle #2 operational	GR/WH	109	Sensor Power
BK	79	Power from TCON ESTOP	BK	110	Sensor Return
N/A	80	Can 2.0/J1939 Shield	OR	111	Steer Signal
GR	81	Can 2.0/J1939 Low	RD	112	Steer Signal to Solenoid Valve
YL	82	Can 2.0/J1939 High	OR/RD	113	Multi-function Valve
GR/WH	83	Tilt signal X axis	BK/RD	114	Load Moment Overweight
GR/BK	84	Tilt signal Y axis	RD/BK	115	Load Moment Underweight
GR	85	Tilt sensor power	OR	116	Hydraulic Oil Cooler

Wire Color Legend

Color	Circuit #	Primary Function	Color	Circuit #	Primary Function
RD	117	Flashing Beacon	RD	141	Primary Boom Angle Signal Safety
OR	118	Lift Speed Reduction	OR	142	Secondary Boom Angle Signal Safety
BL	119	Hydraulic Pressure Sensor Output	BL/RD	143	Drive Enable Left
OR	120	Oil Cooler Fan	BL/WH	144	Drive Enable Right
GR	121	Axle Oscillate Left	RD/WH	145	Calibrate
GR/BK	122	Axle Oscillate Right	BL	146	Jib Bellcrank Up Flow Control
RD/BK	123	Primary Boom Angle Signal Operational	BL/BK	147	Jib Bellcrank Down Flow Control
RD/WH	124	Secondary Boom Angle Signal Operational	BL/WH	148	Jib Bellcrank Sensor
WH/RD	125	Secondary Boom Lockout (Extend Enable)	GR/WH	149	Jib Up/Down Flow Control
WH/BK	126	Secondary Boom Lockout (Riser Down Enable)	GR/BK	150	Hydraulic Generator Bypass
GR	127	ECU Test Switch	GR	151	Hydraulic EDC Output
OR/RD	128	Low Engine Speed	BK	152	Injector Retard
RD/BK	129	Descent Alarm	BK	153	Jib Extend
WH/RD	130	Travel Alarm	BK/WH	154	Jib Retract
BL	131	Motion Alarm	OR/RD	155	Pressure Comp. Enable
GR	132	Platform Load Input	GR/WH	156	Jib Up/Down
GR/WH	133	Platform Load Alarm	BK/RD	157	Jib Extend/Retract
GR/BK	134	Key Switch power	BL/RD	158	Steer Signal Rocker
BL/WH	135	Fuel Pump	BL/WH	159	Steer Joystick Signal
RD	136	Power to Safety Module	WH/RD	160	Propel Joystick Signal
RD/WH	137	Drive Power (P_38)	WH/BK	161	Secondary Boom Joystick Signal
RD/BK	138	Primary Boom Up/Secondary Boom Down-Extend (P_11/30)	OR	162	Joystick 5V DC power
WH/RD	139	Turntable Rotate Flow Control Safety (P_39)	BL/WH	163	Primary Extend/Retract Signal
OR/RD	140	Boom Envelope Safety	RD/WH	164	Primary Up/Down Signal
			WH/RD	165	TT Rotate Signal

Wire Color Legend

Color	Circuit #	Primary Function	Color	Circuit #	Primary Function
OR	166	Boom Length Signal Safety	GR	188	Safety cross check
OR/BK	167	Boom Length Signal Operational	BK	189	Data Receive
BL/RD	168	Primary Boom Hydraulic Valve Lockout	BK/WH	190	Data Transmit
GR	169	Envelope Active LED	WH/RD	191	Multi-Function Pressure Relief
WH/RD	170	Load Sense Relay Source	WH/BK	192	Jib Rotate Left
WH/BK	171	Load Sense Relay Sink	WH/RD	193	Jib Rotate Right
BL	172	UP/DN Flow Control Ground	WH/RD	194	Speed Select Input
BK	173	Ext/Ret Flow Control Ground	OR/RD	195	Electric Brake Source
WH	174	Key Switch Power, Ground Position	YL	196	2.5V Sensor Power
WH/BK	175	Load Sensor Signal Operational	WH	197	Hour Meter
GR/WH	176	Secondary Extend/Retract FC	RD	198	+12V Sensor Power
BL/RD	177	Extend/Retract Lockout	WH/RD	199	Thermal Switch
BK	178	Control Module Status Light	BL	226	Telematics Remote Disable
GR	179	Drive Power Relay	GR	227	Engine Control CAN 2.0 / J1939 Low
BK	180	Lift Power Relay	YL	228	Engine Control CAN 2.0 / J1939 High
OR	181	48 Volt Alternator field (or Battery)	BR	N/A	Ground or Return
RD	182	24 Volt Battery			
BL	183	Envelope or Load Sense Recovery			
WH	184	Program setup Enable			
WH	185	Encode A			
BL	186	Encode B			
BL	187	Bootstrap or Program Enable			

Limit Switches and Angle Sensors

Limit Switch Legend

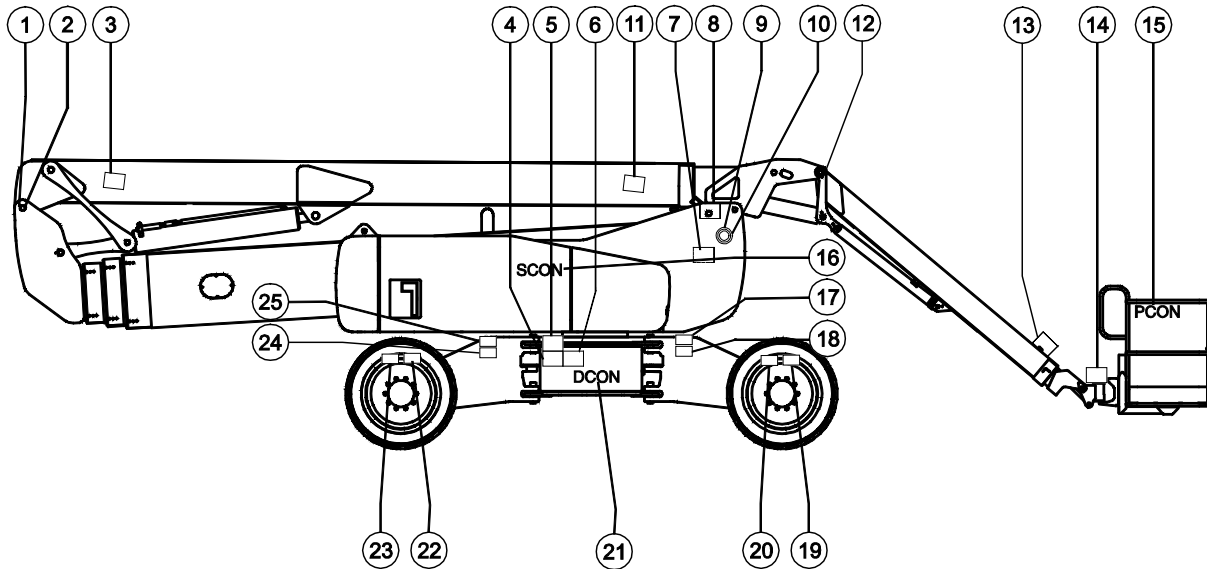

- 1 RSP1AO
- 2 RSP1AS
- 3 LSP1RO
- 4 LST2O
- 5 LST1O
- 6 LST1S
- 7 LSS1RS
- 8 LSS1RO
- 9 RSS1AO
- 10 RSS1AS
- 11 LSP1EO
- 12 RSJ1AO
- 13 LSJ1RO

- 14 Plat Angle Sensor
- 15 PCON
- 16 SCON
- 17 RSRA1SO
- 18 LSRA1ES
- 19 RSLR1SO
- 20 RSRR1SO
- 21 DCON
- 22 RSRF1SO
- 23 RSLF1SO
- 24 LSFA1ES
- 25 RSFA1SO

Limit Switches and Angle Sensors

Types of Limit Switches

There are two types of limit switches, found in various locations throughout the machine: mechanical-type **operational/safety** switches and **rotation** or **angle** sensors. As in aircraft, which features redundant safety systems, each mechanical operational switch is backed up with a separate, independently functioning safety switch.

The mechanical-type **operational** or **safety** switches are used to sense a positive displacement or movement of the limit switch actuator, or arm, as the machine moves through its range of operational functions. The **rotation** or **angle** sensors utilize Hall Effect technology and must be calibrated when replaced. Included in this group are envelope limit switches which sense the extended length and angle of the booms and rotational position of the turntable.

For example, when the secondary boom is fully raised and the operational sensor is activated, it tells the ECM at the ground controls to start extending the secondary boom.

Another example is the drive enable limit switch, which disables the drive function anytime the boom is rotated past the rear tires, indicated by the 'circle' end of the drive chassis. In some cases, the engine will be stopped if safety parameters are exceeded.

Numbering Legend

LS		FA		1	L		O	
LS	Limit Switch	FA	Front Axle	Circuit Number	L	Load moment	O	Operational
LT	Stringpot	RA	Rear Axle		A	Angle	S	Safety
RS	Rotary Sensor	LF	Left Front		D	Down		
		LR	Left Rear		E	Extend		
		RF	Right Front		R	Retract		
		RR	Right Rear					
		J	Jib Boom					
		P	Boom					
		T	Turntable					

Limit Switch Numbering

LSP1RO	Primary boom length retracted
LSP1EO	Primary boom length fully extended
LSS1RO	Secondary boom fully retracted
LSS1RS	Secondary boom fully retracted, safety
LSJ1RO	Jib boom length fully retracted
LST1O	Drive enable, left direction
LST2O	Drive enable, right direction
LST1S	Drive enable safety, retracted axles
LSFA1ES	Front axle fully retracted
LSRA1ES	Rear axle fully retracted

Limit Switches and Angle Sensors

Rotary Sensor Numbering

RSP1AO	Primary boom angle sensor
RSP1AS	Primary boom angle sensor, safety
RSJ1AO	Jib boom angle sensor
RSS1AO	Secondary boom angle sensor
RSS1AS	Secondary boom angle sensor, safety
RSFA1O	Front axle positioning sensor
RSRA1O	Rear axle positioning sensor
RSLF1SO	Left front wheel positioning sensor
RSRF1SO	Right front wheel positioning sensor
RSLR1SO	Left rear wheel positioning sensor
RSRR1SO	Right rear wheel positioning sensor

Limit Switch Functions

Platform Angle Sensor: Measures the angle of the platform. The range of measurement is +/- 20 degrees. The safety cutout is set at +/- 10 degrees from gravity and will disable the primary and secondary boom up/down functions and the platform level up/down functions.

Jib Bell Crank Angle Sensor: Measures the angle of the jib bell crank. The range of measurement is + 60 / -70 degrees.

Safety Controller (SCON): Redundant dual axis tilt sensors measuring the X and Y tilt angles of the turntable. Also provides safety switch logic for function cut-off. Alarm sounds at ± 4.5 degrees.

LSFA1ES: Limit switch, Front Axle #1 Extended Safety. Prevents boom functions with the axles retracted. Switch closes when axles are fully extended.

LSRA1ES: Limit switch, Rear Axle #1 Extended Safety. Prevents boom functions with the axles retracted. Switch closes when axles are fully extended.

LST1O: Limit switch, Turntable #1 Operational. Activates the drive enable zone when the turntable is rotated in the left direction.

LST2O: Limit switch, Turntable #2 Operational. Activates the drive enable zone when the turntable is rotated in the right direction.

LST1S: Limit switch, Turntable #1 Safety. Prevents the turntable from rotating out past either rear tire when axles are retracted.

LSS1RO: Limit switch, Secondary Boom #1 Retracted Operational. NOHC when secondary boom is fully retracted. Used to reduce turntable rotate speed when secondary boom is extended and to disable secondary boom down unit fully retracted.

LSS1RS: Limit switch, Secondary Boom #1 Retract Safety Switch. Backup switch for LSS1RO. Used to cut circuits P9B, P_11 and P_30.

LSJ1RO: Limit Switch, Jib Boom #1 Retract Operational. Switch is held closed when the jib boom fully retracted. Used to limit turntable rotate speed and drive speed when jib boom is extended.

LSP1EO: Limit Switch, Primary Boom #1 Extend Operational. Switch closes when the primary boom is fully extended. NOHC when fully extended.

LSP1RO: Limit Switch, Primary Boom #1 Retract Operational. Switch closes when the primary boom is retracted. NOHC when fully retracted.

Limit Switches and Angle Sensors

Rotary Sensor Functions

RSP1AO: Rotary Sensor, Primary #1 Angle Operational. Provides operational primary boom angle positioning relative to secondary boom angle.

RSP1AS: Rotary Sensor, Primary #1 Angle Safety. Provides safety primary boom angle positioning relative to secondary boom angle.

RSJ1AO: Rotary Sensor, Jib #1 Angle Operational. Used to level jib bell crank relative to the primary, secondary and turntable angles.

RSS1AO: Rotary Sensor, Secondary #1 Angle Operational. Used to measure the angle of the secondary boom. Lowers drive speed when elevated, sequences secondary boom up/extend and down/retract.

RSS1AS: Rotary Sensor, Secondary #1 Angle Safety. Backup safety angle sensor for RSS1AO. Cuts power to circuits P9B, P_11 and P_30 if the secondary boom drifts down while still extended.

RSFA10: Rotary Sensor, Front Axle #1 Operational. Provides front axle positioning information for adjusting steering neutral setting during axle extension.

RSRA10: Rotary Sensor, Rear Axle #1 Operational. Provides front axle positioning information for adjusting steering neutral setting during axle extension.

RSLF1SO: Rotary Sensor, Left Front #1 Steer Operational. Provides wheel position information during steering. Master wheel in all steer modes except rear steer.

RSRF1SO: Rotary Sensor, Right Front #1 Steer Operational. Provides wheel position information during steering.

RSLR1SO: Rotary Sensor, Left Rear #1 Steer Operational. Provides wheel position information during steering. Master wheel for rear steer mode.

RSRR1SO: Rotary Sensor, Right Rear #1 Steer Operational. Provides wheel position information during steering.

Circuit Connector Legend

Number	Description	Number	Description
J9	Ribbon connector from TCON to membrane #1	J59	2 pin Deutsch connector for primary boom up valve
J10	Ribbon connector from TCON to membrane #2	J60	2 pin Deutsch connector for primary boom down valve
J11	Black 23 pin AMP connector on TCON	J61	2 pin Deutsch connector for primary boom ext/ret flow control valve
J12	Black 35 pin AMP connector on TCON	J62	2 pin Deutsch DT pri boom extend valve
J13	White 23 pin AMP connector on TCON	J63	2 pin Deutsch DT pri boom retract valve
J14	White 35 pin AMP connector on TCON	J65	2 pin Deutsch connector for secondary boom extend valve
J15	Black 4 pin DTP connector on PCON	J66	2 pin Deutsch connector for secondary boom retract valve
J17	16 pin Molex mini fit circuit board to key switch	J67	2 pin Deutsch connector for secondary boom up valve
J20	12 pin Deutsch connector lower/upper limit switch harness	J68	2 pin Deutsch connector for secondary boom down valve
J21	Black 23 pin AMP connector on PCON	J69	2 pin Deutsch connector for turntable rotate flow control
J22	White 35 pin AMP connector on PCON	J70	2 pin Deutsch connector for turntable rotate CW valve
J23	10 pin ribbon connector PCON to LED driver board	J71	2 pin Deutsch connector for turntable rotate CCW valve
J24	20 pin Molex connector LED driver board	J76	2 pin Deutsch DT platform rotate CW valve (Y70)
J25	6 pin Deutsch connector on drive/steer joystick	J78	2 pin Deutsch connector for jib boom up valve
J28	6 pin Deutsch connector on secondary boom up/extend and down/retract joystick	J79	2 pin Deutsch connector for jib boom down valve
J29	16 pin Molex conn on PCON PCB	J82	2 pin Deutsch connector for prox kill
J31	Black 23 pin AMP connector on DCON	J84	2 pin Deutsch connector for platform footswitch
J32	White 23 pin AMP connector on DCON		
J46	4 pin Deutsch connector on LSS1RS		
J49	4 pin Deutsch connector on sec boom retract (LSS1RO)		
J55	6 pin Deutsch connector on platform tilt sensor		
J57	3 pin Deutsch connector on RPM solenoid		
J58	2 pin Deutsch connector for pri boom up/down flow control		

Circuit Connector Legend

Number	Description	Number	Description
J87	2 pin Deutsch connector for two-speed motor stroke valve	J121	12 pin Deutsch gray SCON connector
J91	2 pin Deutsch connector for right rear steer right valve	J122	12 pin Deutsch black SCON connector
J92	2 pin Deutsch connector for right rear steer left valve	J124	2 pin Deutsch connector for drive enable right limit switch (LST10)
J93	2 pin Deutsch connector for left rear steer right valve	J125	2 pin Deutsch connector for drive enable left limit switch (LST20)
J94	2 pin Deutsch connector for left rear steer left valve	J126	4 pin Deutsch connector for drive enable safety limit switch (LST1S)
J95	2 pin Deutsch connector for right front steer right valve	J127	6 pin Deutsch connector for primary boom up/down, ext/ret and turntable joystick
J96	2 pin Deutsch connector for right front steer left valve	J128	6 pin Deutsch connector for jib boom up/down, ext/ret and platform rotate
J97	2 pin Deutsch connector for left front steer right valve	J129	2 pin Deutsch connector for boom composite/lower limit switch harness
J98	2 pin Deutsch connector for left front steer left valve	J135	2 pin Deutsch connector for jib boom bellcrank up
J99	2 pin Deutsch connector for axle extend valve	J136	2 pin Deutsch connector for jib boom bellcrank down
J100	2 pin Deutsch connector for axle retract valve	J137	2 pin Deutsch connector for front axle safety switch
J106	2 pin Deutsch connector for brake release valve	J138	2 pin Deutsch connector for rear axle safety switch
J107	3 pin Deutsch connector for right rear steer sensor	J140	2 pin Deutsch connector for jib extend
J108	3 pin Deutsch connector for left rear steer sensor	J141	2 pin Deutsch connector for jib retract
J109	3 pin Deutsch connector for right front steer sensor	J146	2 way Deutsch connector for lower limit switch harness/engine harness
J110	3 pin Deutsch connector for left front steer sensor	J147	1 way Deutsch connector for platform power jib/primary
J114	6 pin Deutsch connector for primary boom angle sensor (PBAS)		
J119	2 pin Deutsch connector for jib not retracted		
J120	4 pin Weatherpack EDC connection		

Circuit Connector Legend

Number	Description	Number	Description
J148	1 way Deutsch connector for platform ground jib/primary	J223	CAN Gateway 8 pin Molex connector
J149	2 pin Deutsch connector, boom composite	J224	Telematics connector
J150	4 pin Deutsch connector, boom composite	J228	Gateway to TCON interface connector
J151	3 pin Deutsch connector, CAN connector, jib/primary	J231	Tier IV A1 or D2.1 ECU connector
J152	3 pin SAE Deutsch tee	J232	Tier IV K1 or D2.2 ECU connector
J153	2 pin Deutsch connector for engine and manifold harness	J233	Tier IV engine interface connector
J154	6 pin Deutsch connector for secondary boom angle sensor		
J157	2 pin Deutsch connector for PCON manifold/boom composite harness		
J160	4 pin Deutsch connector for front axle angle sensor		
J161	4 pin Deutsch connector for rear axle angle sensor		
J162	3 pin Deutsch connector for jib bellcrank angle sensor		
J163	2 pin Deutsch connector for secondary boom up/down flow control		
J164	2 pin Deutsch connector for secondary boom extend/retract flow control		
J165	12 pin Deutsch connector located at PCON		
J166	6 pin Deutsch connector for jib bellcrank sensor		
J168	1 way 0.25 inch slide terminal for belt generator excite		
J169	20 pin Molex connector for circuit board to joystick and switches #2		
J175	2 pin Deutsch connector		

Drive Chassis and Platform Controller Pin Legend

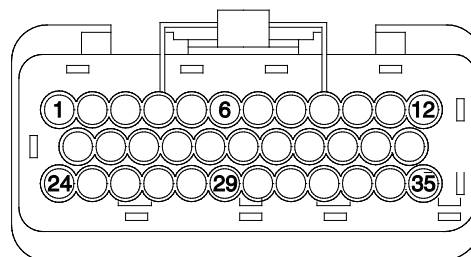
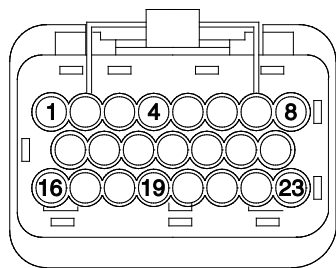

Pin Numbering - 23 pin connector

Pin Numbering - 35 pin connector

J21	Plat Controller	J22	Plat Controller	J32	Drive Chassis	J31	Drive Chassis
1	GNDPCON - BR	1	VLVRET1 - BR	1	VLVRET1 - BR	1	GND-DCON - BR
2	P52PCON - WH	2	V153JBE - BK	2	V61AXRT - GR	2	P21DCON - WH
3	(UNUSED)	3	V18PRR - GR/BK	3	V60AXEX - GR/WH	3	P53LS - WH/BK
4	S56PRV - RD	4	V17PRL - GR	4	V29MS - RD/WH	4	(UNUSED)
5	(UNUSED)	5	V43JU - GR	5	(UNUSED)	5	S56PRV - RD
6	(UNUSED)	6	V44JD - GR/BK	6	(UNUSED)	6	C61AXRT - GR
7	P56PRV - RD/WH	7	V14PLU - OR	7	(UNUSED)	7	(UNUSED)
8	(UNUSED)	8	V15PLD - OR/BK	8	V36RRS - BL	8	(UNUSED)
9	(UNUSED)	9	V154JBR - BK/WH	9	V37RRS - BL/BK	9	(UNUSED)
10	(UNUSED)	10	(UNUSED)	10	C111RRS - OR	10	(UNUSED)
11	(UNUSED)	11	C90PXS - RD/BK	11	C111LRS - OR	11	(UNUSED)
12	(UNUSED)	12	GR/YL	12	C111RFS - OR	12	(UNUSED)
13	(UNUSED)	13	OR	13	C111LFS - OR	13	(UNUSED)
14	(UNUSED)	14	BK	14	VLVRET2 - BR	14	(UNUSED)
15	C47OUT - WH/BK	15	C88PTS - RD/BK	15	V32BRK - WH/RD	15	(UNUSED)
16	C46HN - WH	16	C64LS - OR/BK	16	V36LRS - BL	16	(UNUSED)
17	D81CAN(-) - GR	17	C56FTS - RD	17	V37LRS - BL/BK	17	D81CAN(-) - GR
18	D82CAN(+) - YL	18	C154JBR - BK/WH	18	V36RFS - BL	18	D82CAN(+) - YL
19	(UNUSED)	19	P85RET - BR	19	P110RT - BK	19	(UNUSED)
20	(UNUSED)	20	C84TAY - GR/BK	20	P109ANG - GR/WH	20	C60FAP - GR/WH
21	(UNUSED)	21	P85PTS - GR	21	V37RFS - BL/BK	21	C60RAP - GR/WH
22	(UNUSED)	22	P87RET - BR	22	V36LFS - BL	22	(UNUSED)
23	P23PCON - BK	23	P87PTS - RD	23	V37LFS - BL/BK	23	P61LSA - GR
		24	(UNUSED)				
		25	(UNUSED)				
		26	(UNUSED)				
		27	(UNUSED)				
		28	V146JBU - BL				
		29	V147JBD - BL/BK				
		30	P109JBS - GR/WH				
		31	P110JBS - BK				
		32	C148JBS - BL/WH				
		33	(UNUSED)				
		34	VLVRET2 - BR				
		35	(UNUSED)				



Safety Controller Pin Legend

J121	Safety Controller
1	S132LDS - BL/WH
2	S73SLE - BL/RD
3	(UNUSED)
4	C145CAL - RD/WH
5	(UNUSED)
6	D82CAN (+) - YL
7	D81CAN (-) - GR
8	S59CNK - GR/WH
9	S56PRV - RD
10	S137PLL - RD/WH
11	S139TRF - WH/RD
12	GNDSCON - BR

Pin Numbering for 12 pin connectors

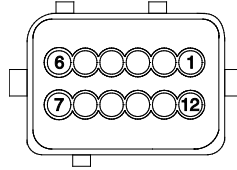

J122	Safety Controller
1	P21DCON - WH
2	C142SBS - OR
3	C141PBS - RD
4	C60AXE - GR/WH
5	S12SB - BL/WH
6	S13DE - BL/RD
7	P53LS - WH/BK
8	S140ENL - OR/RD
9	P54ENG - BK/WH
10	P58LS - RD/BK
11	S56PRV - RD
12	C61AXR - GR

Turntable Controller Pin Legend

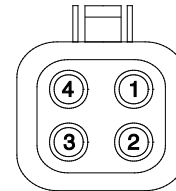
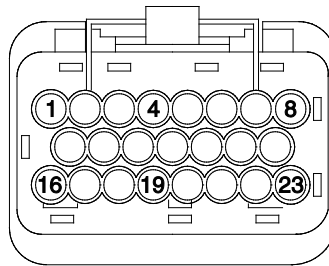
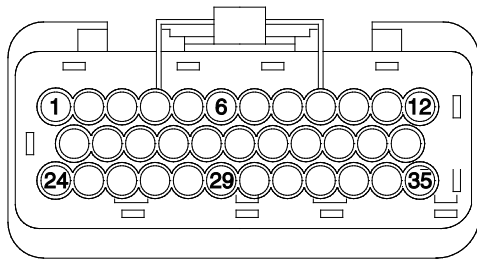

Pin Numbering - 35 pin connector

Pin Numbering - 23 pin connector

Pin Numbering - 4 pin connector

J11	Turntable Controller	J12	Turntable Controller	J13	Turntable Controller	J14	Turntable Controller
1	GNDPCON - BR	1	GNDSCON - BR	1	(UNUSED)	1	VLVRET4 - BR
2	P52PCON - WH	2	P21DCON - WH	2	C35RPM - BK/RD	2	V03PUD - RD/WH
3	C46HN - WH	3	P53LS - WH/BK	3	C21IGN - WH	3	V09PER - BK/RD
4	C47OUT - WH/BK	4	P54ENG - BK/WH	4	C34SA - BK/WH	4	V06TRF - WH/RD
5	P23PCON - BK	5	S56PRV - RD	5	(UNUSED)	5	V12SUD - BL/WH
6	S56PRV - RD	6	P53LS - WH/BK	6	(UNUSED)	6	V176SER - GR/WH
7	P56PRV - RD/WH	7	P58LS - RD/BK	7	C46HRN - WH	7	VO1PBU - RD
8	(UNUSED)	8	S59CNK - GR/WH	8	(UNUSED)	8	V02PBD - RD/BK
9	R117FB - RD	9	S140ENL - OR/RD	9	C33STR - BK	9	V07PBE - BK
10	(UNUSED)	10	C61AXR - GR	10	C30EDC - WH	10	V08PBR - BK/WH
11	C145CAL - RD/WH	11	(UNUSED)	11	C31EDC - WH/BK	11	(UNUSED)
12	(UNUSED)	12	(UNUSED)	12	C25PSR - WH/BK	12	V11SBD - BL/BK
13	(UNUSED)	13	C64LS - OR/BK	13	C26TSR - WH/RD	13	(UNUSED)
14	(UNUSED)	14	C65LOF - BL/WH	14	(UNUSED)	14	VLVRET5 - BR
15	(UNUSED)	15	C144DER - BL/WH	15	(UNUSED)	15	(UNUSED)
16	(UNUSED)	16	C73SBR - BL/RD	16	(UNUSED)	16	(UNUSED)
17	D81CAN(-) - GR	17	C67SBD - BL	17	S137PLL - RD/WH	17	VLVRET5 - BR
18	D82CAN(+) - YL	18	C64LS - OR/BK	18	C41RPM - OR/BK	18	VLVRET5 - BR
19	(UNUSED)	19	C70PBR - BL/WH	19	S139TRF - WH/RD	19	V10SBU - BL
20	(UNUSED)	20	C71PBE - BL/BK	20	(UNUSED)	20	V73SBR - GR/BK
21	(UNUSED)	21	(UNUSED)	21	(UNUSED)	21	V72SBE - GR
22	(UNUSED)	22	(UNUSED)	22	C45GEN - GR/WH	22	(UNUSED)
23	(UNUSED)	23	(UNUSED)	23	(UNUSED)	23	(UNUSED)
J15	Turntable Controller	24	(UNUSED)			24	(UNUSED)
1	B1BAT - RD	25	SNSR GND - BR			25	V04TRL - WH
2	GND - BR	26	P109ANG - GR/WH			26	V05TRR - WH/BK
3	GND - BR	27	(UNUSED)			27	VLVRET7 - BR
4	(UNUSED)	28	C143DEL - BL/RD			28	(UNUSED)
		29	(UNUSED)			29	(UNUSED)
		30	(UNUSED)			30	VLVRET6 - BR
		31	(UNUSED)			31	(UNUSED)
		32	C123PBS - RD/BK			32	C27AUX - RD
		33	C124SBS - OR/BK			33	(UNUSED)
		34	S140ENL - OR/RD			34	V155PCE - OR/RD
		35	GND16 - BR			35	V150HG - GR/BK



Engine Relay and Fuse Panel Legend - Deutz BF4L 2011, TD2011L04i, Perkins 1104C-44 and 804D-33T

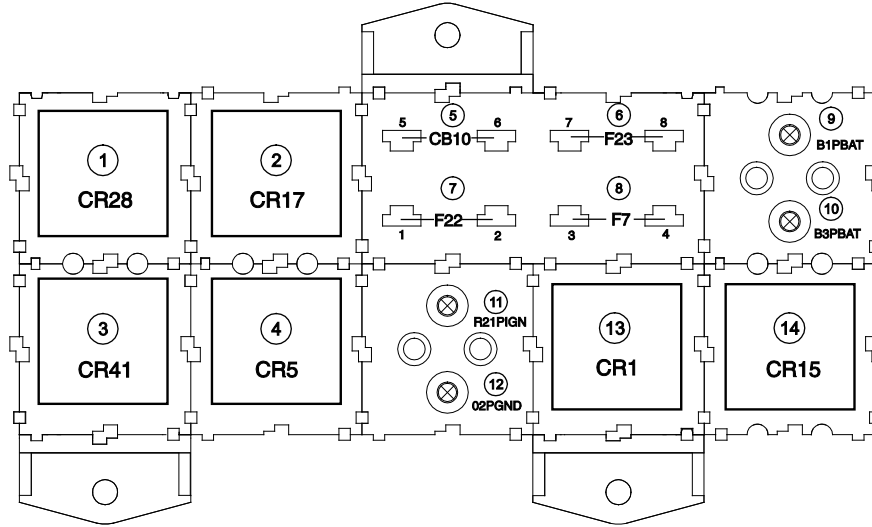





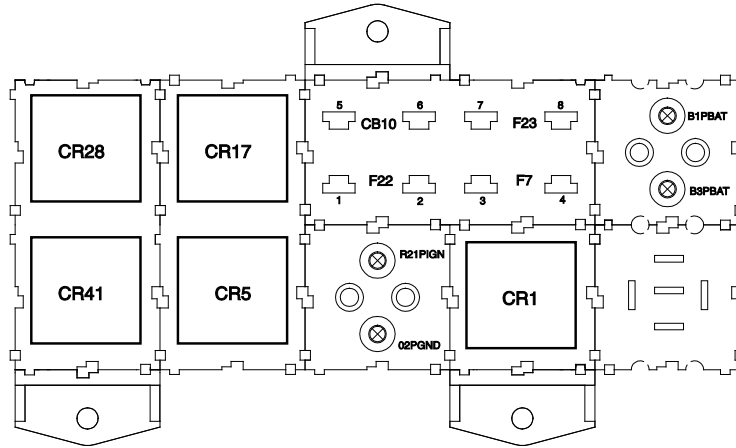





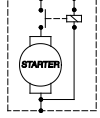







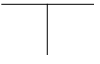
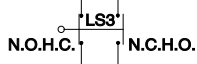
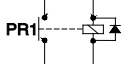

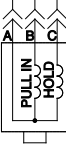

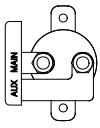
Number	Component	Description
1	CR28	Engine / Fuel Relay
2	CR17	Hydraulic Oil Cooler Fan Relay
3	CR41	Flashing Beacon Relay
4	CR5	Horn Relay
5	CB10	Circuit Breaker, 20A, RPM Solenoid
6	F23	Fuse, 30A, Engine / Start / Alternator
7	F22	Fuse, 60A, Glow Plug
8	F7	Fuse, 20A, Hydraulic Oil Cooler Fan / Horn
9	B1PBAT	Power from Battery
10	B3PBAT	Fused Power from B1
11	R21PIGN	Ignition Fuse, 20A, RPM Solenoid
12	02PGND	Ground
13	CR1	Start Relay
14	CR15	Glow Plug Relay

Engine Relay and Fuse Panel Legend - Cummins B4.5L and B3.3T

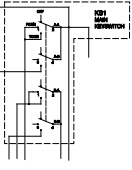
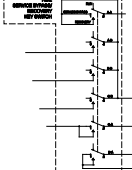
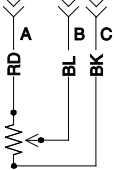
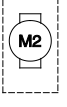
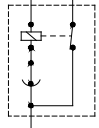
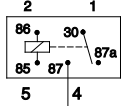
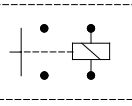
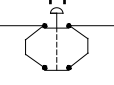

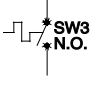
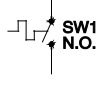





Number	Component	Description
1	CR28	Engine Run / Alternator Relay
2	CR17	Hydraulic Oil Cooler Fan Relay
3	CR41	Flashing Beacon Relay
4	CR5	Horn Relay
5	CB10	Circuit Breaker, 20A, RPM Solenoid
6	F23	Fuse, 30A, Engine / Start / Alternator
7	F22	Fuse, 60A, Glow Plug
8	F7	Fuse, 20A, Hydraulic Oil Cooler Fan / Horn
9	B1PBAT	Power from Battery
10	B3PBAT	Fused Power from B1
11	R21PIGN	Ignition Fuse, 20A, RPM Solenoid
12	02PGND	Ground
13	CR1	Start Relay

Electrical Symbols Legend

				
Battery	Motor	Horn or alarm	Flashing beacon	Gauge
				
Diode	Hour meter	LED	Fuse with amperage	Foot switch
				
Circuit connection	Limit Switch	Power relay	Coil with suppression	Fuel or RPM solenoid
				
Connection - no terminal	Battery separator	Circuits crossing no connection	Quick disconnect terminal	Circuit breaker with amperage
				
Main Key switch	Service Bypass Key switch	Steer sensor	Auxiliary Pump	Tilt sensor
				
Relay	Power relay	Emergency Stop button	Hydraulic oil cooling fan	Gauge sending unit
				
Oil temperature switch normally open	Coolant temperature switch - normally open	Oil pressure switch normally closed	Control relay contact normally open	Diode starting aid, glow plug or flame ignitor

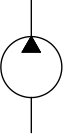
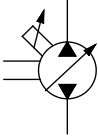
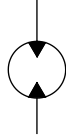
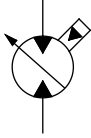
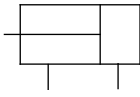
Hydraulic Symbols Legend

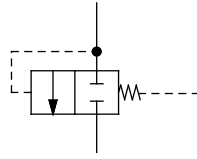
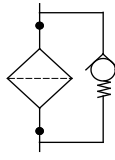
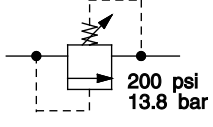
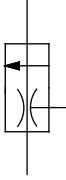
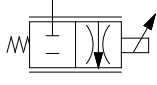
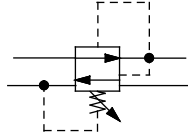
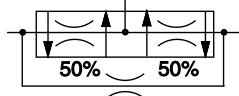
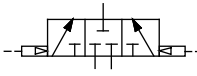
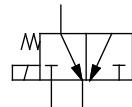
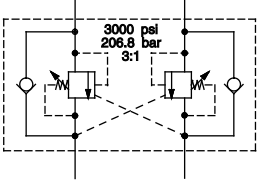
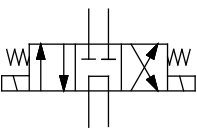
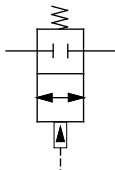
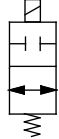
 <p>0.037 in 0.94 mm</p> <p>Orifice with size</p>	 <p>Check valve</p>	 <p>Shut off valve</p>	 <p>Brake</p>
 <p>Pump, fixed displacement</p>	 <p>Pump, bi-directional variable displacement</p>	 <p>Motor, bi-directional</p>	 <p>Motor, 2 speed bi-directional</p>
 <p>Cylinder, double acting</p>	 <p>Pump, prime mover (engine or motor)</p>	 <p>Shuttle valve, 2 position, 3 way</p>	 <p>Differential sensing valve</p>
 <p>Filter with bypass relief valve</p>	 <p>200 psi 13.8 bar</p> <p>Relief valve with pressure setting</p>	 <p>Priority flow regulator</p>	 <p>Solenoid operated proportional valve</p>
 <p>Pressure reducing valve</p>	 <p>50% 50%</p> <p>Flow divider/combiner valve</p>	 <p>Pilot operated 3 position, 3 way shuttle valve</p>	 <p>Solenoid operated 2 position, 3 way directional valve</p>
 <p>3000 psi 206.8 bar 3:1</p> <p>Counterbalance valve with pressure and pilot ratio</p>	 <p>Solenoid operated 3 position 4 way directional valve</p>	 <p>Pilot operated 2 position, 2 way directional valve</p>	 <p>2 position, 2 way solenoid valve</p>

Perkins 1104C-44 and 804D-33T Engine Electrical Schematic

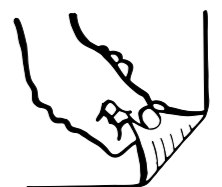

Cummins B4.5L and B3.3T Engine Electrical Schematic

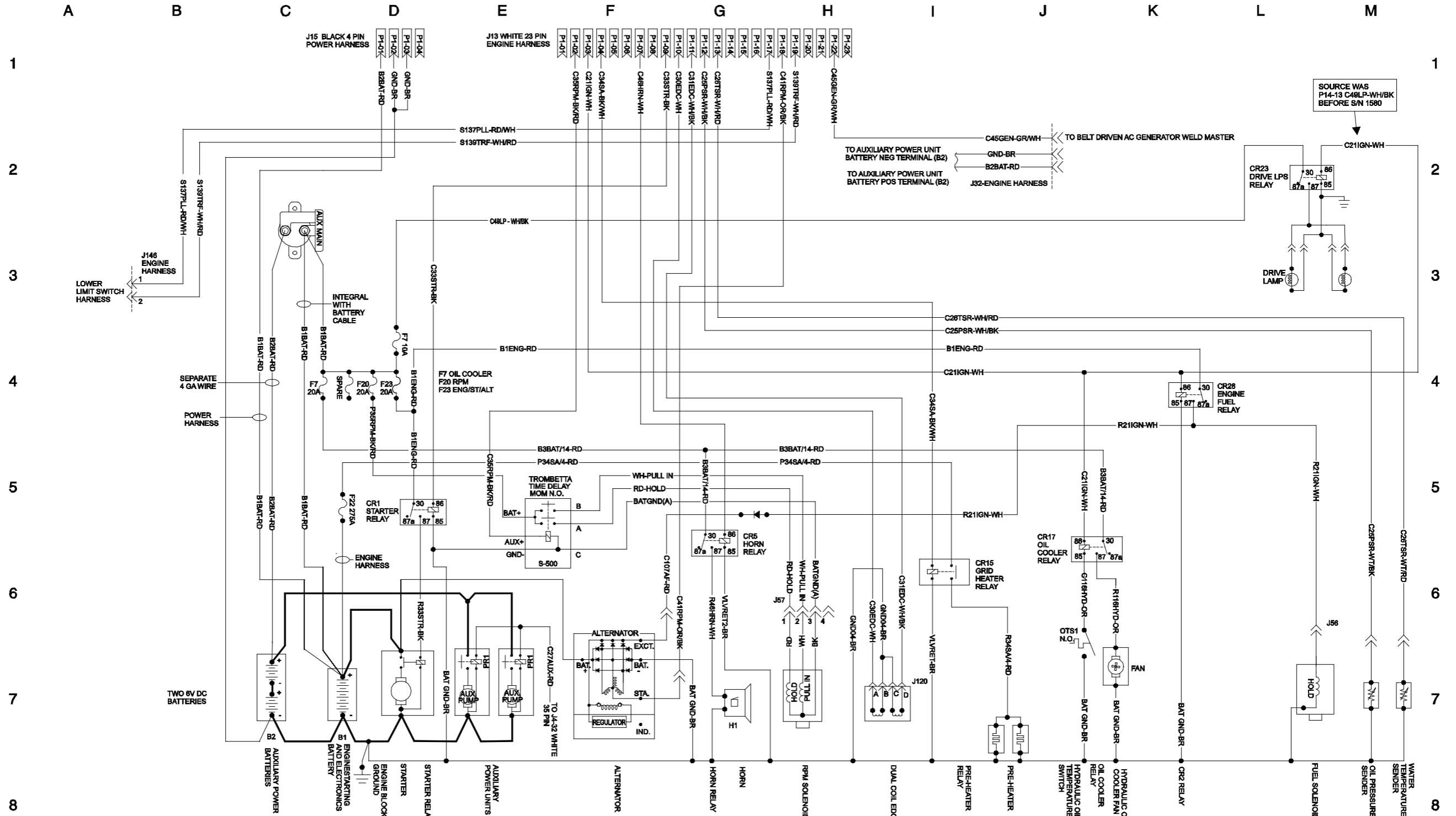

Cummins B4.5L and B3.3T Engine Electrical Schematic

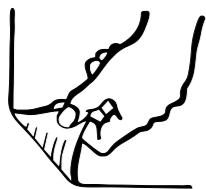

Generator Wiring Schematic

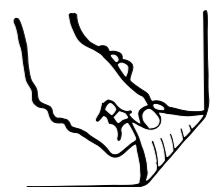

Generator Wiring Schematic

A B C D E F G H I J K L M

1

120V AC W/REGULATOR

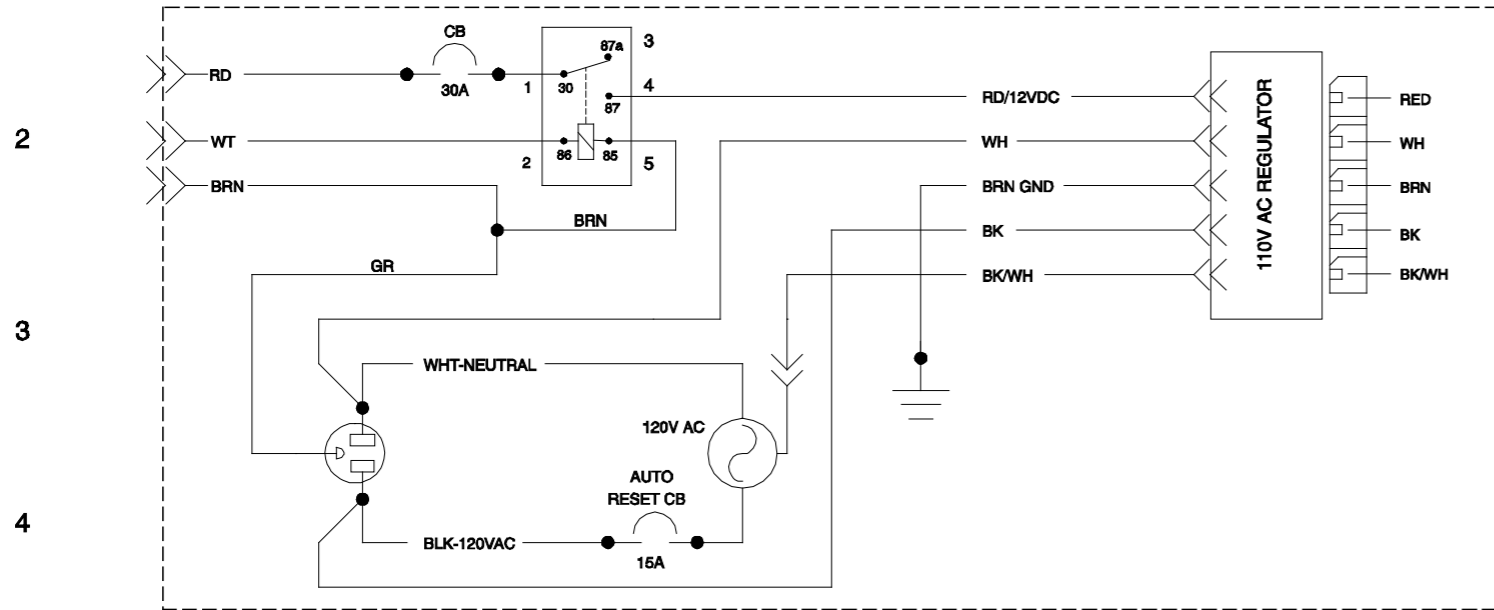

2

3

4

1

120V AC W/O REGULATOR

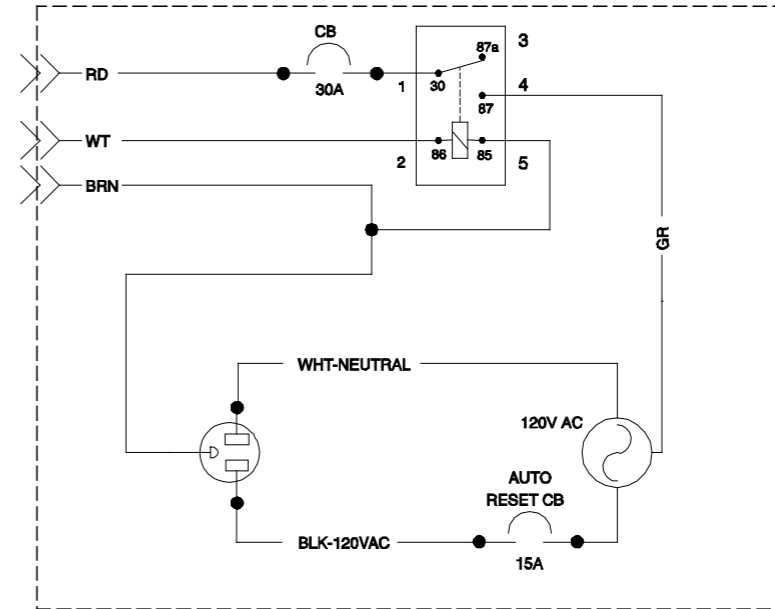

2

3

4

5

220V AC W/REGULATOR

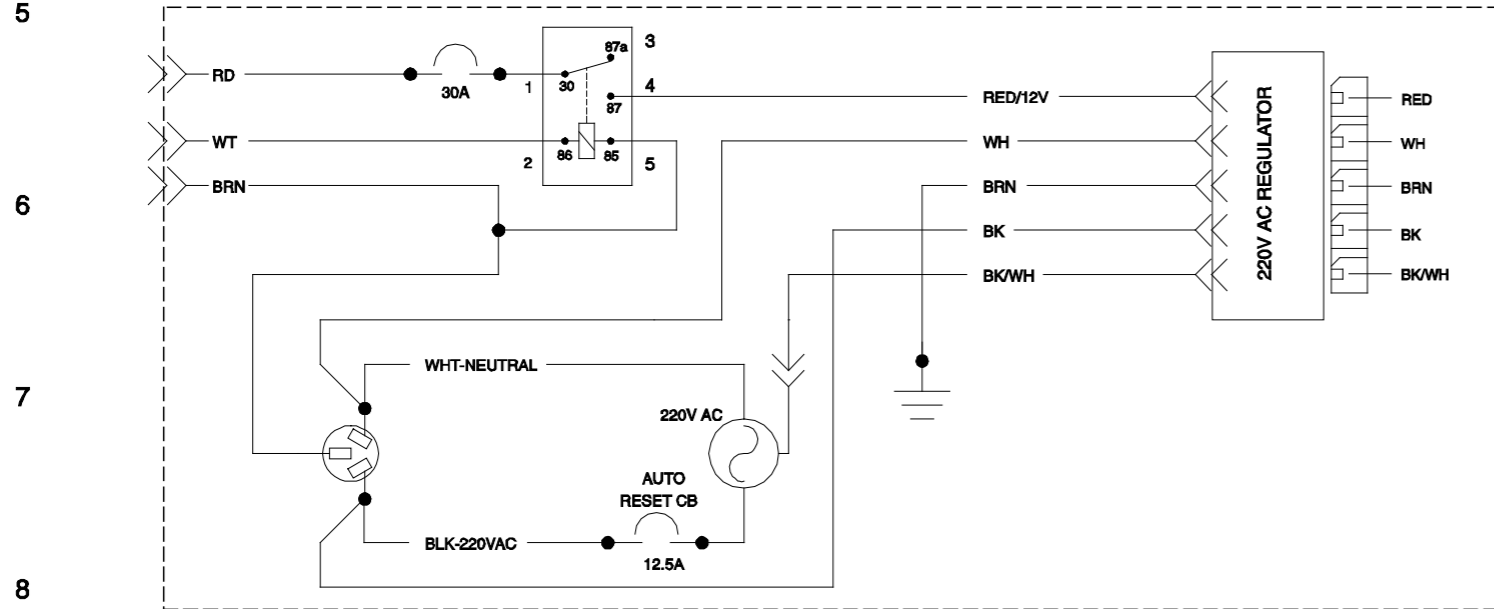

6

7

8

5

6

7

8

Hydraulic Generator (Welder Option)

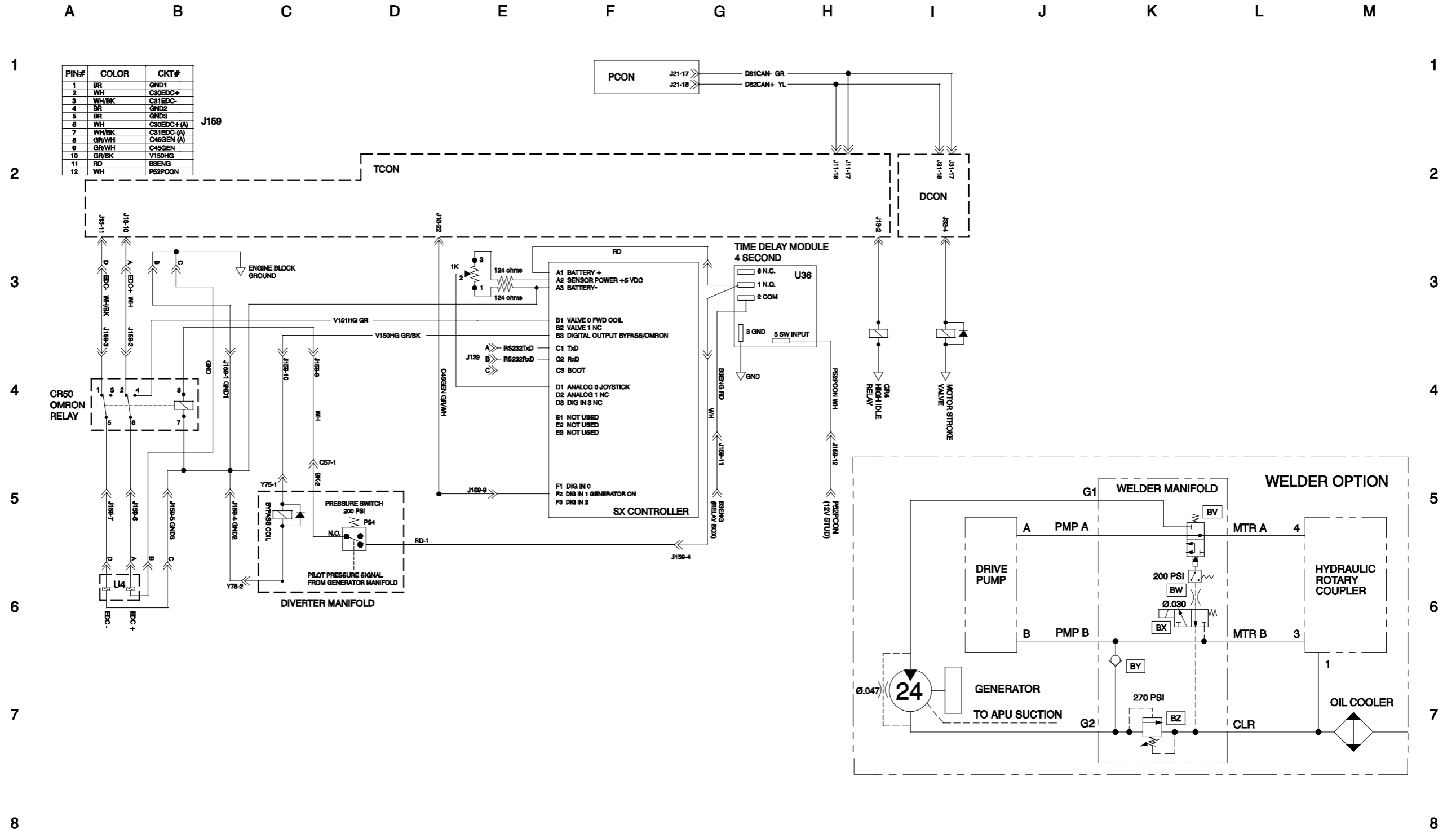

Hydraulic Generator (Welder Option)

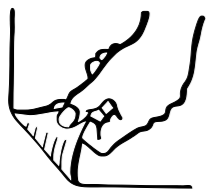

Hydraulic Schematic
(before serial number 180, except for serial number 102)

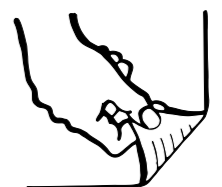

Hydraulic Schematic (before serial number 180, except for serial number 102)

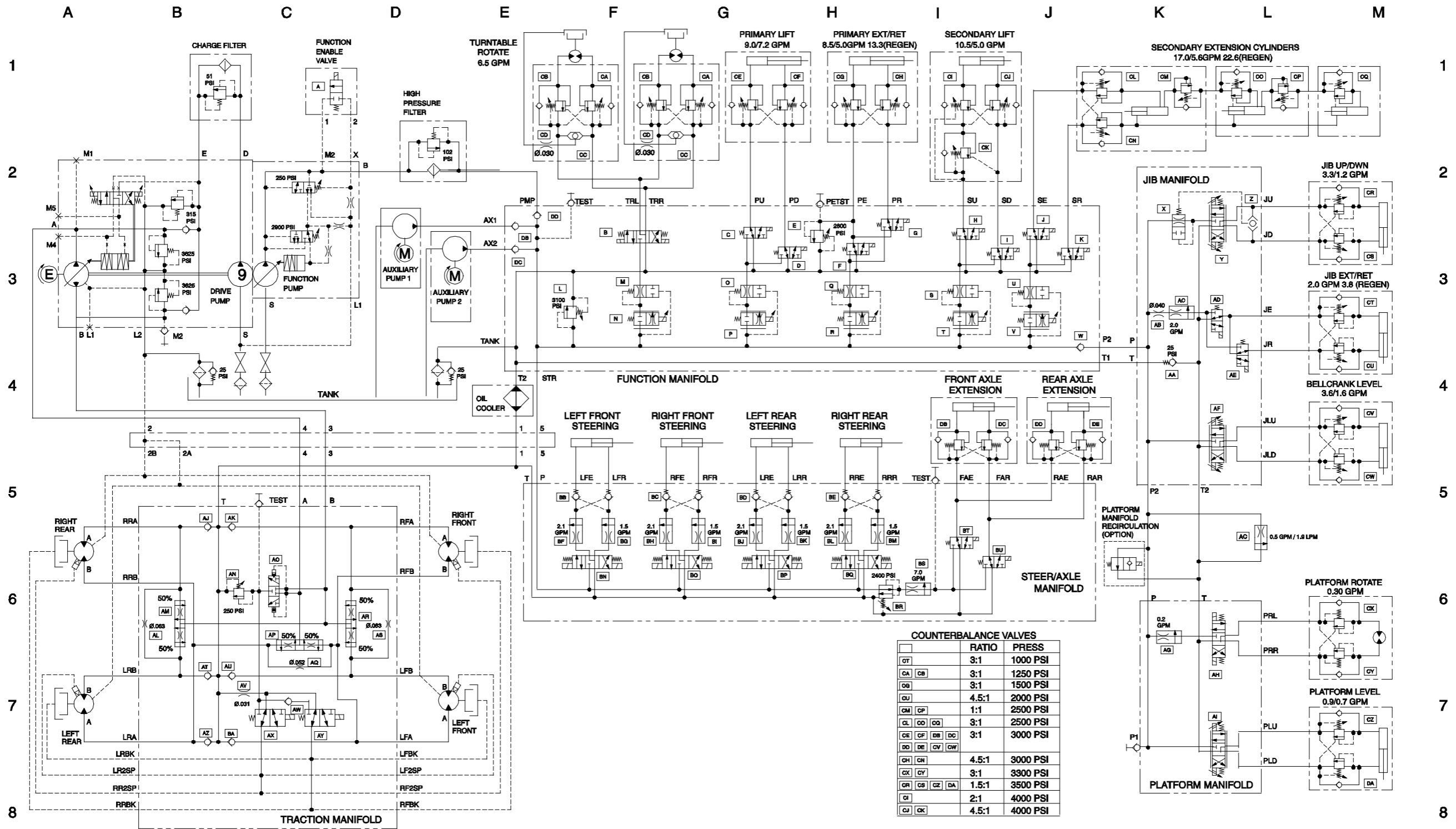

Hydraulic Schematic (serial number 102 and from serial number 180 to 534)

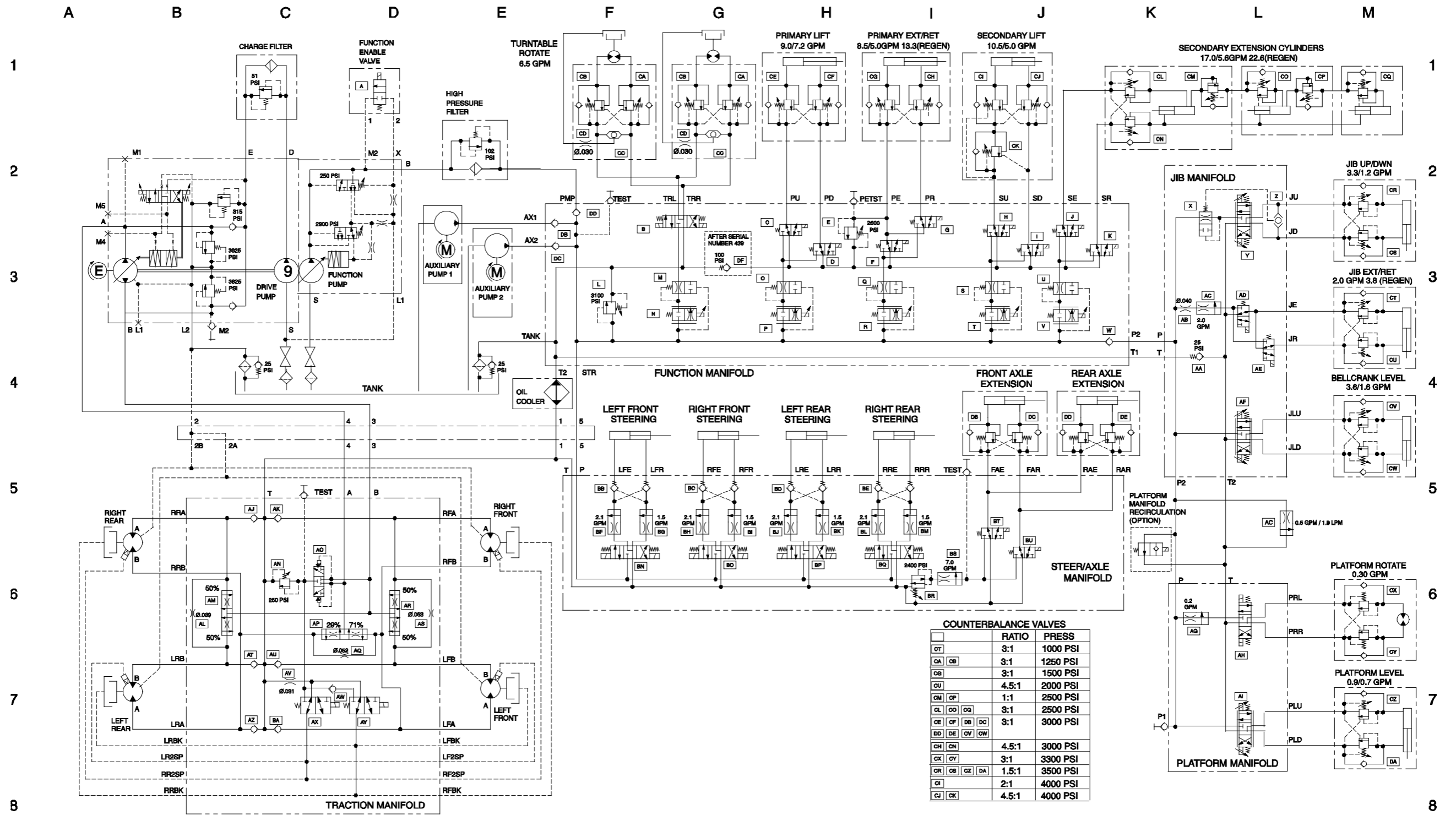

COUNTERBALANCE VALVES		
Symbol	RATIO	PRESS
CT	3:1	1000 PSI
CA CB	3:1	1250 PSI
CG	3:1	1500 PSI
CU	4.5:1	2000 PSI
CM OP	1:1	2500 PSI
CL OQ OQ	3:1	2500 PSI
CE CF DB DC	3:1	3000 PSI
DD DE OV OW		
CH CN	4.5:1	3000 PSI
OX OY	3:1	3300 PSI
OR OS OZ DA	1.5:1	3500 PSI
CI	2:1	4000 PSI
CJ CK	4.5:1	4000 PSI

HS0080F

Hydraulic Schematic
(serial number 102 and from serial number 180 to 534)

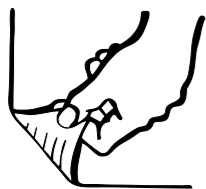

Hydraulic Schematic (from serial number 535)

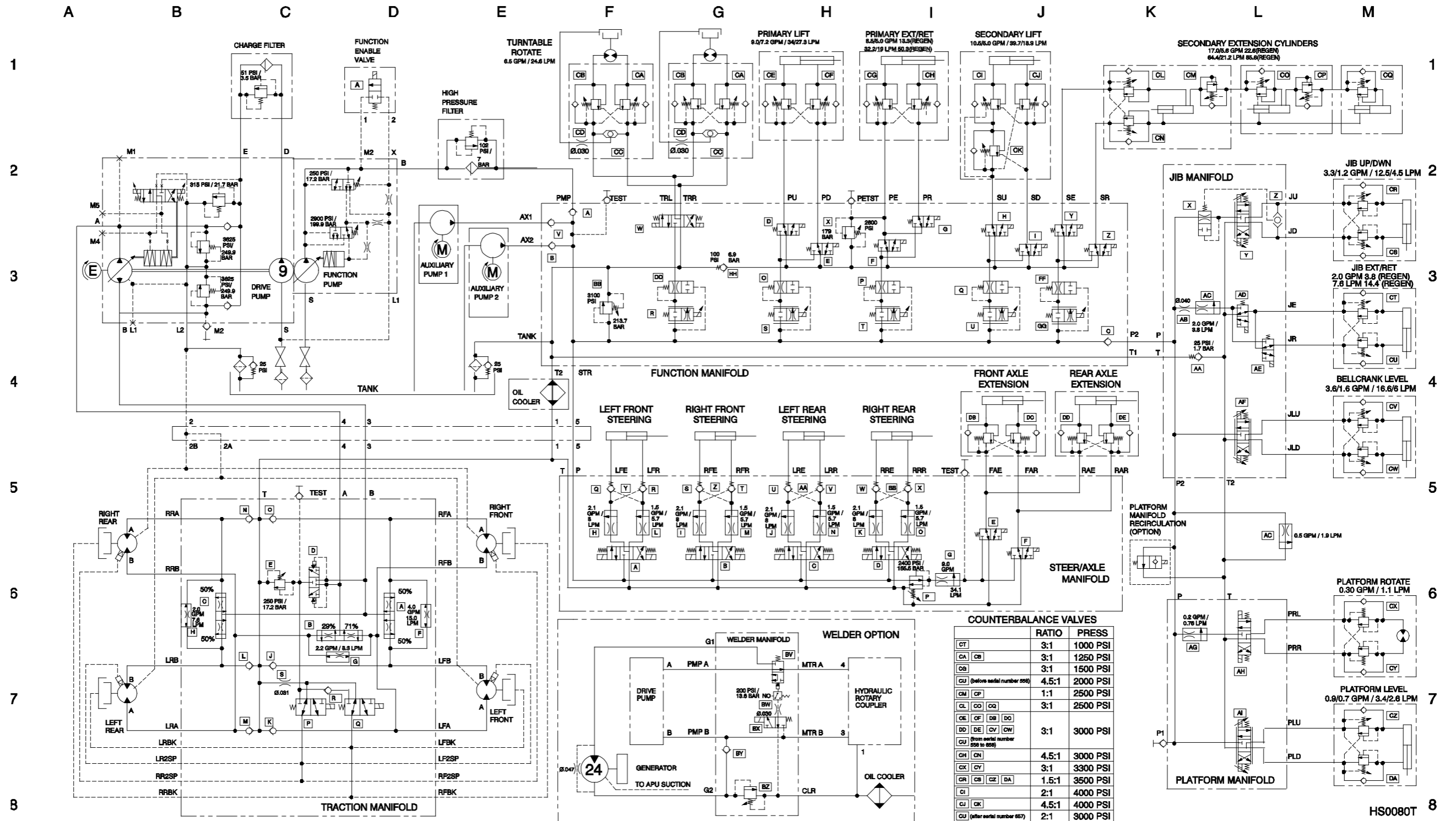

**Hydraulic Schematic
(from serial number 535)**

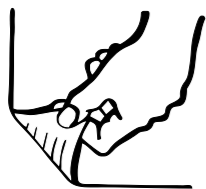

Genie Z-135
Electrical Schematic
w/ Deutz Engine
ES0366J



1
2
3
4
5
6
7
8
9
10
11
12
13
14
15
16

A B C D E F G H I J K L M N O P Q R S T U V W X Y Z

California Proposition 65

Warning

The exhaust from this product contains chemicals known to the State of California to cause cancer, birth defects or other reproductive harm.

Genie North America
Phone 425.881.1800
Toll Free USA and Canada
800.536.1800
Fax 425.883.3475

Genie Australia Pty Ltd.
Phone +61 7 3375 1660
Fax +61 7 3375 1002

Genie China
Phone +86 21 53853768
Fax +86 21 53852569

Genie Singapore
Phone +65 67533544
Fax +65 67533544

Genie Japan
Phone +81 3 6436 2020
Fax +81 3 5445 1231

Genie Korea
Phone +82 2 558 7267
Fax +82 2 558 3910

Genie Brasil
Phone +55 11 4082 5600
Fax +55 22 4082 5630

Genie Holland
Phone +31 183 581 102
Fax +31 183 581 566

Genie Sweden
Phone 0046 3157 5101
Fax 0046 3157 5104

Genie France
Phone 0033 237 260 986
Fax 0033 237 260 998

Genie Iberica
Phone 0034 900 808 110
Fax 0034 935 725 080

Genie Germany
Phone 0800 180 9017
Phone 0049 4221 491 810
Fax 0049 4221 491 820

Genie U.K.
Phone 0044 1476 584 333
Fax 0044 1476 584 330

Genie Mexico City
Phone +52 55 5666 5242
Fax +52 55 5666 3241

Distributed By: